

ICCONS®



CONSTRUCTION SUPPLIES FOR SERIOUS USERS



www.iccons.com.au



IPG4

GENERAL

- Inner Carton Quantity
- Outer Carton Quantity
- Drill Diameter

HEAD STYLES

- Phillips
- Phillips (Button Head)
- Pozi
- Square
- Torx
- Hex (Internal)
- Hex with Internal Torx
- Hex Head
- Hex Flanged
- Nut-setter

ANCHORING

- Head Width
- Thread Width
- Thread length
- Minimum Embedment Depth
- Minimum Hole depth
- Maximum Material Thickness
- Splice Anchor Fixture Thickness
- Metal Drive and Nylon Anchor Fixture Thickness
- Wall Anchor Fixture Thickness
- Toggle Strap Wall Thickness
- Strike Anchor Fixture Thickness
- Grip Nut Wall Thickness
- Clearance hole
- Thread length

ANCHORING cont.

- Countersunk Head Height
- Countersunk Head Width
- Internal Thread
- Eye Hole Diameter
- Maximum Torque
- Purlin Material Thickness
- Screw-bolt Eye
- Beam Clamp Depth
- Beam Clamp Clearance Hole

ADHESIVES

- Anchor Width
- Plug Length
- Threaded Insert Length
- Threaded Insert Diameter

CONCRETE NAILING SYSTEMS

- Nail Head Width
- Nail Shank Width
- Nail Length
- Washer Diameter
- Channel Strut Width
- Channel Strut Depth
- Channel Strut Length
- Pipe Diameter
- Insulation Thickness
- Rivets Body Diameter
- Rivets Length
- Rivets Grip Range

SCREWS

- Head Width
- Shank Width
- Length
- Shank Length
- Material Thickness
- Minimum Embedment
- Head Style

DRILLING

- Drill Diameter
- Drill Working Length
- Drill Total Length
- Chisel Head Width
- Hole Saw Diameter
- Hole Saw Length
- Hole Saw Thread

DIAMOND









- Hole Diameter
- Disk Diameter
- Core Diameter
- Core Length

Screw Conversion Gauge to mm	
Gauge	mm
4	2.9
6	3.5
8	4.2
10	4.8
12	5.5
14	6.3

This publication is copyright. No part of this publication may be reproduced without the prior written consent of ICCONS® Pty Ltd. ICCONS® Pty Ltd is committed to continued product development & improvement, therefore ICCONS® Pty Ltd reserves the right to alter product specification as required. ICCONS® Pty Ltd has made every effort to ensure information included in this product guide is correct at the time of printing, it is the responsibility of the user to ensure product selected is suitable for their application. ICCONS® Pty Ltd. Accept no responsibility or liability for any errors or omissions. This product guide should be used as a guide only. ICCONS® Pty Ltd fully exclude any liability to any person in respect of, or arising out of any reliance by such person on any contents of this publication for any purpose. For further information go to www.icons.com.au or contact ICCONS® Pty Ltd.



LEGEND / COLUMN SYMBOLS	2
"WHAT'S NEW" PRODUCTS	4 - 7
OUR COMPANY	8 - 9
GLOBAL SUPPLY PARTNERS	10 - 11
NCC PRODUCT SELECTION	12 - 13
SELECTION GUIDES	14 - 17
ENGINEERING SUPPORT / DESIGN FIX SOFTWARE	18 - 19

	ANCHORING	20 - 68
	ADHESIVES	70 - 83
	CONCRETE NAILING SYSTEMS	84 - 99
	RIVETS	100 - 107
	SCREWS	108 - 172
	DRILLING	173 - 192
	DIAMOND CUTTING & CORING	193 - 213
	TOOLS	214 - 227

Follow Us



Facebook
ICCONS Pty Ltd



Instagram
iccons.ptltd



LinkedIn
ICCONS Pty Ltd

© Copyright 2019, ICCONS® Pty Ltd, All Rights Reserved

Powers® is a registered trademark of Stanley, Black & Decker
Ramset™ is a registered trademark of ITW
Hilti is a registered trademark of HiltiCorp., Schaan

WHAT'S NEW

ATSevo **FRILSIDER**
YOUR FIXING FACTORY



Shallow Embedment
Thin Panel Anchor

P22

NEW

Industrial Torque Wrench



40 - 200Nm

P23

NEW

FM753® 3DG

FRILSIDER
YOUR FIXING FACTORY



NCC™ NATIONAL CODE COMPLIANT 3DG COATING ETA

National Code Compliant

P28

NEW

THUNDERBOLT PRO XTM Screw-bolts



NCC™ NATIONAL CODE COMPLIANT ETA

316 Stainless Steel

P32

NEW

THUNDERBOLT PRO Screw-bolts



New 5 & 6mm sizes
Zinc & Galvanised

P33

NEW

THUNDERBOLT PRO Tie Down Anchor



Galvanised

P34

NEW

THUNDERBOLT Eye Screw-bolt



New 8mm size

P35

NEW

TOGE DOBEL TSO Suspension anchor

NCC™ NATIONAL CODE COMPLIANT ETA



National Code Compliant

P39

NEW

Grabcon® SDS Plus Imperial Drill Bits



For Grabcon® Hex & Csk

P40

NEW

Grabcon® Frame Galvanised



GAL

P41

Concrete Framing Screw

NEW

The Original **BLUE BANGER HANGER**



P42

PIP for Wood form

NEW

The Original **BLUE BANGER HANGER**



P43

SDI for Steel form

NEW

apob SA-Plus Lipped Drop-in



NCC NATIONAL CODE COMPLIANT

ETA

P44

Approved 10 x 25mm

NEW

THUNDERBOLT PRO XTM Rod Hanger



NCC NATIONAL CODE COMPLIANT

ETA

P46

National Code Compliant

NEW

Hangerz for Timber



P47

M10 New 50mm size

NEW

Beam Clamp



P47

M10 & M12

NEW

Nylon Nailin



P50

5 x 40mm size

NEW

X1EVO-L



FRULSIDER
YOUR FIXING FACTORY

P54

X1 Longer sizes

NEW

TOGE TID Metal Insulation Fastener



P60

Fire Rated / Galvanised

NEW

Dog-Bites™



P64

Multi-purpose Wall Anchor

NEW

B+BTEC BIS-PE



ETA

NCC NATIONAL CODE COMPLIANT

P72

1400ml Tube size

NEW

Pure-Epoxy GEN 0



NCC NATIONAL CODE COMPLIANT

ETA

P72

More features Higher Performance

NEW

Hybrid GEN 2



NCC NATIONAL CODE COMPLIANT

ETA

P73

More features Higher Performance

NEW

CFCHT Class 8.8 High Tensile Studs



P80

Galvanised

NEW

WHAT'S NEW

GTIFX24+ Fuel cell



P85

24 + months shelf life

NEW

GTIFB Black Insulation Fasteners



P91

Sizes 25, 40 & 75mm

NEW

Rivets



P100

Scell-it®

NEW

RT-18V E5



P106

Rivet Tools

NEW

Stainless Steel- Bi-Metal



P122

SD Hex, Pan & 5 Series

NEW

Hex Shed Head



P129

SD 14g with 5/16 (12g) drive

NEW

FIBRE-STARS

For Fibre Cement Sheet to 0.75
-2.5mm steel



Coming Soon

P133

Single Screw SQ2 drive

NEW

STET Aesthetic Architectural
Tamper Resistant Screw

FRULSIDER
YOUR FIXING FACTORY



P138

Coarse Thread & 5 Series Fine Thread

NEW

Stainless Steel



P139

Type 17 - 25 & 50mm sizes

NEW

14 Gauge Class 3



More Sizes

Type 17

P141

NEW

Countersinking Tool for Timber



THE BETTER BIT

P148

NEW

Needle Point Steel Frame



Truss Fixing

P152

NEW

FIBRE-STARS

For Fibre Cement Sheet to 0.75 -2.5mm steel



Collated PH2 drive

P156

NEW

786C - 10 Gauge Collated



Laminating screw

P157

NEW

Ceramic Tile Drill Bit



P187

CERAMIC

NEW

B+BTEC

FB750W
Angular
Tile Drill



Dust less
drilling

P194

Premium Tile Bits

NEW

B+BTEC



Auto Feed Unit

P197

NEW

B+BTEC

Karat 400
Diamond
Coring
Rig



P198

NEW

B+BTEC Pro Series



More Sizes Added

P202

NEW

KEYANG IW18BL-H-NT

18V
High
Torque
Impact
Tool



1,000 Nm

BL DC MOTOR

P219

NEW

KEYANG IW18BL-NT

18V
1/2"
Impact
Tool



270 Nm

BL DC MOTOR

219

NEW

KEYANG MC18BL-NT

18V Oscillating
Multi Tool



BL DC MOTOR

220

NEW

KEYANG RS18BL-O-NT

18V Reciprocating
Saw

Coming soon



220

NEW

KEYANG BR18L-NT

18V Blower



221

NEW



OUR COMPANY

ICCONS® is an exciting Australasian construction products provider, dedicated to supplying a broad range of innovative product systems and services. With global iconic supply partners, ICCONS® specialise in providing the latest technology in Construction Fastening Systems, Power Tools and Accessories. The highly experienced team at ICCONS® has a proven track record with decades of construction products knowledge and are well known within the industry for their integrity and respect. This has helped to cement iconic connections across the globe that have fostered strong commercial ties with the core foundation being trust, loyalty and performance. The ICCONS® product range includes many global iconic brands that have chosen ICCONS® as one of their global partners. See for yourself & explore the serious connections ICCONS® have partnered with on pages 10 & 11.

CONSTRUCTION SUPPLIES FOR ALL SERIOUS USERS

With the increased demand for higher credential anchoring systems and for specific projects calling for problem solving and significant innovation, our European supply partners provide ICCONS® with the ability to locate products and systems that will solve the most challenging applications. The ICCONS® SERVICE Program is set to deliver to the Australian marketplace a refreshing, versatile and innovative service that will problem solve applications, locate, source and deliver.

DISTRIBUTION PARTNER SUPPORT

ICCONS® Australian distribution network provides national coverage like no other. With our sales support team, the ICCONS® dealer network is always available to assist on-site with training and technical recommendations. Complementing this SERVICE the ICCONS® COMMERCIAL ENGINEERING program provides engineering design support and expertise for our distribution partners and design professionals looking for innovative anchoring solutions that comply with the latest National Construction Code requirements. With 9 warehouse locations throughout Australia, New Zealand and Asia, ICCONS® is leading the way in supporting its distribution partners and their customers.





| NATIONAL COVERAGE |
 | NATIONAL CODES |
 | INTERNATIONAL PRODUCTS |

ICCONS® APPROVED SOLUTIONS

Over recent years there has been a significant move by the Australian fastening industry to promote the need for better regulation for anchors and fasteners for critical applications. This has been achieved through the development of standards and technical specifications providing minimum requirements for code compliant anchoring systems. With European technical approvals/assessments (ETA's) being the benchmark and with the recent introduction of the first ever Post-installed Fastening Australian Standard AS 5216:2018, **ICCONS®** are leading the way with compliance;

- AS 5216:2018 compliant anchoring solutions
- EOTA Approved Anchoring Solutions
- Cracked & Un-Cracked Concrete options (TR029)
- Seismic Approved Fastenings (TR045 C1 & C2)
- High Corrosion Stainless Steel (HCR) Anchors
- Potable Water Approvals (WRAS)
- Fire Performance Data and Approvals
- Major Infrastructure and Tunnelling Expertise
- AS 3850: 2015 Compliant Bracing Anchors
- Undercut Anchors with unique benefits
- Complete carbide drilling & diamond coring solutions

GLOBAL SUPPLY PARTNERS

ICCONS® works in collaboration with ISO 9001 certified manufacturing partners to ensure high quality products and code compliant anchoring systems are brought to the Australian marketplace under either the ICCONS® brand or our global supply partner's brand. We are proud to be offering numerous fastening systems with recognised global approvals for high performance mechanical and adhesive anchoring.



SYMPAFIX - ICCONS® global backing is strengthened further with the addition of sister company SYMPAFIX® based in Europe. The partnership of ICCONS® and SYMPAFIX® helps to bring international knowledge and expertise to major Australian projects.



B+BTec is a system manufacturer of unique heavy duty concrete anchoring systems and specialised concrete coring equipment. Established in 1970, B+BTec anchoring systems have been heavily used in major European tunnelling projects and are backed by numerous technical approvals and test reports from independent institutions worldwide.



Toge Dubel - is one of the leading innovative screw manufacturers in the world, specialising in concrete screw anchor technology. Screw anchors give a positive connection that is free of expansion pressure in most base materials. Available in zinc and stainless steel & various head styles with fire rating, seismic approval (C1 & C2) and EOTA cracked concrete approval.



Friulsider Spa is an Italian company specialising in the production of fixing and fastening systems. Friulsider Spa was established in 1966. Today, Friulsider is a world leader in Seismic approved anchors and high performance ETA certified nylon fixings. Friulsider is the first company in Europe to have a heavy-duty mechanical expansion anchor with EOTA C2 Seismic certification.



apolo - Technical competence, innovative developments, and design proficiency are characteristic features of apolo Fastening Systems. apolo produces efficient system fixing solutions and specialised clamping systems focusing on Electrical, Plumbing, HVAC and Fire Services.



Heller, a successful manufacturer of drill bits for professional requirements, was founded more than 160 years ago. State-of-the-art computer aided technology and select raw materials allow Heller to push the limits of modern drilling technology. Heller's new range of Hollow, Self Cleaning Vacuum drill bits are revolutionary examples of their capabilities.



Scell-it is represented through ICCONS® with its quality rivet range, hand held rivet tool, 18v rivet tools & unique hollow wall anchor tool. These are perfect examples of Scell-its commitment to develop innovative products for professional use .



Muro Corporation was first established in 1953 in Tokyo Japan. In 1986 Muro developed its patented Vislider Auto Feed Screw Driving System and Visrope collated screws; over the ensuing years Muro has remained the leader in the field of Auto Feed Screw Driving Technology.



Keyang specialise in manufacturing and selling D.C. motors for electric tools and major car electrical components. The Keyang power tool side of the business began in 1977, ICCONS have ranged the necessary tools to compliment our anchoring, drilling & cutting segments.

GLOBAL CONNECTIONS



COMPLIANT PRODUCTS IN ACCORDANCE WITH SA TS 101:2015 & AS 5216:2018

ICCONS® offers world leading chemical and mechanical anchoring solutions for the Australian Market, complying with requirements referenced in the National Construction Code 2016 and European Technical guidelines.

In May 2018 SA TS 101:2015 was superseded by Australian Standard AS 5216:2018 (Design of post-installed and cast-in fastenings in concrete). AS 5216:2018 follows the same design, testing and qualification requirements previously outlined in SA TS 101:2015 with

the addition of some editorial modifications and corrections.

SA TS 101:2015 although superseded is still a primary reference in the current 2016 NCC and the official document to follow when complying with the deemed-to-satisfy requirements. AS 5216:2017 will become a primary reference in the next NCC update in May 2019.

Mechanical NCC anchors provide:

- Heavy duty high performance
- Zinc, Galvanised and SS options
- Hex and countersunk head styles
- Multiple lengths providing flexibility

ChemSelect offers:

- Fast Cure, Maximum Strength, Highly Approved Adhesives.
- Anchorage Design Software.
- Zinc, GAL, SS & HCR Anchors.
- Threaded Studs, Internal Threaded Inserts, Asphalt Threaded Inserts.
- Manual, Lithium Battery Cordless and Pneumatic Applicators.
- Specialist Hole Cleaning & Deep Embedment Kits.
- Brick and Block work Anchoring
- Solutions.

Icon legend

National Code Compliant	C1 Earthquake Seismic Approval	Overhead Applications	Rebar	VOC (Green Building)
European Technical Assessment	C2 Earthquake Seismic Approval	Water Filled Holes	Threaded Stud / Insert	Clear Zinc Coating
Cracked Concrete Approval	CE Certification	Core Drilled Holes	Working Time	Stainless Steel Material
Fire Rated	Load Performance	Masonry/Brickwork	Curing Time	3DG (Nautilus Coating)
				DesignFIX Software

ICCONS® SEISMIC SOLUTIONS

ICCONS® is the first company to provide Australia and New Zealand with a complete range of C1 and C2 Heavy Duty fixings for Structural Applications in Seismic Risk applications and projects. ICCONS® has pioneered the introduction of C1 and C2 certified Mechanical and Chemical anchors into Australia and NZ. Through a "World's Best Practice" assessment, ICCONS® has collaborated with its global supply partners Friulsider, BBTEC and Sympafix in making C1 and C2 certified fixing systems a reality for the engineering fraternity



NCC CHEMSELECT RANGE	Chemical Anchors	Icon Legend														Page			
		National Code Compliant	European Technical Assessment	Cracked Concrete Approval	C1 Earthquake Seismic Approval	C2 Earthquake Seismic Approval	Fire Rated	CE Certification	Load Performance	Overhead Applications	Water Filled Holes	Core Drilled Holes	Masonry/Brickwork	Rebar	Threaded Stud / Insert		Working Time MMS @ 20°C (Dry Holes)	Curing Time MMS @ 20°C (Dry Holes)	VOC (Green Building)
NCC CHEMSELECT RANGE	BIS-P POLYESTER 300mL / 420mL 1 CODE BLUE															6	45		73
	BIS-V VINYLESTER 300mL / 420mL 1 CODE GREEN															6	45		71
	BIS-HY HYBRID 280mL / 420mL 1 CODE PLATINUM															3	30		69
NCC CHEMSELECT RANGE	BIS-PE PURE EPOXY 385mL / 585mL 1 CODE RED															30	10 hrs		67
	VDP-Q CAPSULE VINYLESTER M8 - M24 1 CODE GOLD															unlimited	20		75



Mechanical Anchors

	National Code Compliant	European Technical Assessment	Cracked Concrete Approval	C1 Earthquake Seismic Approval	C2 Earthquake Seismic Approval	Fire Rated	CE Certification	Load Performance	Overhead Applications	Size Range Approved	Coating / Material	Page
ATS-EVO S Hex Head ¹ 										M6 – M24	Clear Zinc	21
ATS-EVO SK Countersunk Head ¹ 										M6 – M12	Clear Zinc	23
FM-753® Crack BDG ¹ & A4 316 SS ¹ 										M8 – M16	3DG COATING 316 SS	27
FM-753® BDG ¹ 										M20	3DG COATING	28
TSM High Performance ¹ 										6mm – 14mm	Clear Zinc 316 SS	31
TB1-Plus Thru Bolt ¹ 										M8 – M16	Clear Zinc	28
TB1-A4-Plus Thru Bolt (A4 316 SS) ¹ 										M8 – M12	316 SS	29
Thunderbolt® Pro XTM Screw-bolt ^{1 & 2} 										6mm – 12mm	316 SS	32
SB2-Plus Screw-bolt ¹ 										8mm – 14mm	Galvanised	30
SA Plus Lipped & Di-Plus Drop-in Anchors ² 										SA Plus (M10) Di Plus (M8 – M12)	Clear Zinc	34
FM-X5 Nylon Frame Fixing ³ 										Ø 10mm (85mm – 160mm)	3DG COATING 316 SS	57
TPP Hammer Screw ⁴ 										Ø 5, 6, 8mm	Clear Zinc 316 SS	52
CA-Plus Ceiling Anchor ² 										Ø 6 x 35mm	Clear Zinc	49
Thunderbolt®PRO XTM ETA Rod Anchor ² 										M10 Internal Thread (Ø 6 x 57mm)	Clear Zinc	46
TSM IM Internal Thread Anchor ¹ 										M8/M10 Internal Thread (Ø 6 x 55mm)	Clear Zinc	46
TSO Spring Anchor ² 										TSO (Ø 6 x 40mm)	Clear Zinc	39

NCC MECHANICAL RANGE NCC MECHANICAL RANGE NCC MECHANICAL RANGE NCC MECHANICAL RANGE NCC MECHANICAL RANGE NCC MECHANICAL RANGE NCC MECHANICAL RANGE

¹ Product complies with SA TS 101:2015 / AS 5216:2018 and ETAG 001 Part 1-5 as relevant. ETAG 001 Part 1-5 has been superseded by EAD 330232-00-0601 (Part 1-4) and EAD 330499-00-0601 (Part 5).
² Product complies with ETAG 001 Part 6 (Anchors for multiple use for non-structural applications).
³ Product complies with ETAG 020 Annex C (Plastic anchors for use in concrete and masonry for non-structural applications).
⁴ Product complies with ETAG 014 (ETICS) which has been superseded by EAD 330196-01-0604.



Product Name	44	44	44	44	46	46	46	47	47	47	48	48	49	50	51	51	51	52	53	53	54	57	58	59	60	60	61	62	63	63	63	64	65	65	66			
apolo Lip Drop-in Anchor - Approved	Green																																					
Lip Drop-in Anchor	Green	Green																																				
Sympafix Di-Plus Drop-in Anchor - Approved	Green	Green	Green																																			
Drop-in Anchor	Green		Green																																			
TOGE TSM IM Hanger- Approved	Green	Green	Green	Green	Green	Green	Green	Green	Green	Green	Green	Green	Green	Green	Green	Green	Green	Green	Green	Green	Green	Green	Green	Green	Green	Green	Green	Green	Green	Green	Green	Green	Green	Green	Green	Green	Green	
ThunderBoit®Pro-XTM Rod hanger - Approved	Green	Green	Green	Green	Green	Green	Green	Green	Green	Green	Green	Green	Green	Green	Green	Green	Green	Green	Green	Green	Green	Green	Green	Green	Green	Green	Green	Green	Green	Green	Green	Green	Green	Green	Green	Green	Green	
Hangerz™ for Concrete	Green	Green	Green	Green	Green	Green	Green	Green	Green	Green	Green	Green	Green	Green	Green	Green	Green	Green	Green	Green	Green	Green	Green	Green	Green	Green	Green	Green	Green	Green	Green	Green	Green	Green	Green	Green	Green	
Hangerz™ Vertical & Side for Steel & Timber	Green	Green	Green	Green	Green	Green	Green	Green	Green	Green	Green	Green	Green	Green	Green	Green	Green	Green	Green	Green	Green	Green	Green	Green	Green	Green	Green	Green	Green	Green	Green	Green	Green	Green	Green	Green	Green	
Wedge-Nut for use in Bondek® Profile	Green																																					
Beam Clamp	Green																																					
Strike™ Mushroom & Countersunk Head								Green	Green																													
Strike™ Anchor Formwork								Green	Green																													
Sympafix CA-Plus Splice Anchor								Green	Green																													
Nylon Nailin Anchor								Green	Green																													
Metal Drive Anchor								Green	Green																													
Metal Drive Hammer Screw								Green	Green																													
Nylon Grey Plug								Green	Green																													
friulsider TPP Hammer Screw								Green	Green																													
friulsider FM-XP® Nylon Anchor								Green	Green																													
friulsider TUP / TUP3 Nylon Anchor								Green	Green																													
friulsider FM-X1® evo Universal Anchor								Green	Green																													
friulsider FM-X5® Nylon Frame Fixing								Green	Green																													
friulsider FM-X5® SAFER Nylon Frame Fixing								Green	Green																													
friulsider FM-X5® TOP Nylon Frame Fixing								Green	Green																													
friulsider FM-ISO MAX Insulation Fixing								Green	Green																													
TOGE TID METAL Insulation Fixing								Green	Green																													
friulsider FOX Lightweight Material Fixing								Green	Green																													
PVC Wall Plug								Green	Green																													
Toggle Strap								Green	Green																													
Spring Toggles								Green	Green																													
Toggle Plug								Green	Green																													
Dog-Bites™								Green	Green																													
Plaster-Bites™								Green	Green																													
Grip Nut EPDM								Green	Green																													
Hollow Wall Anchor								Green	Green																													



CONCRETE NAILING SELECTION CHART

Note: Competitor compatibility shown in this should only be taken as a guide.

- Recommended
- Adaptor Required
- Adapter May Be Required

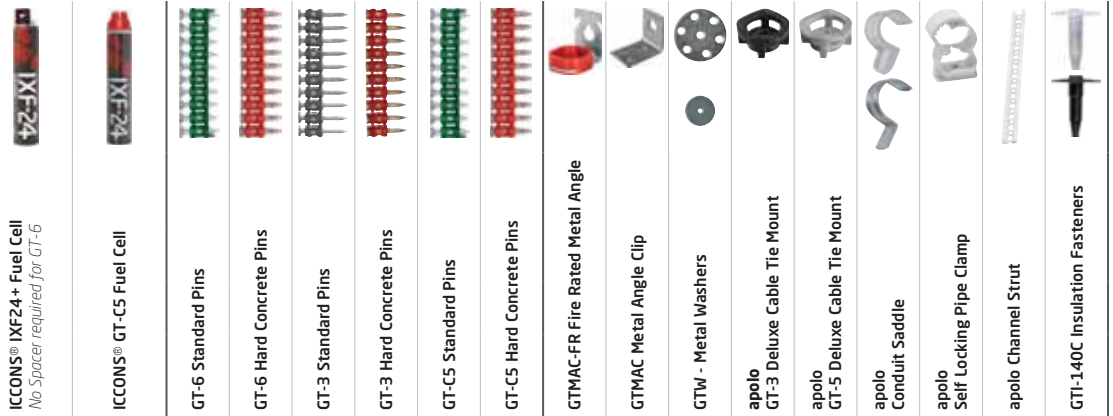

	ICCONS® IXF24+ Fuel Cell <i>No Spacer required for GT-6</i>	ICCONS® GT-C5 Fuel Cell	GT-6 Standard Pins	GT-6 Hard Concrete Pins	GT-3 Standard Pins	GT-3 Hard Concrete Pins	GT-C5 Standard Pins	GT-C5 Hard Concrete Pins	GTMAC-FR Fire Rated Metal Angle	GTMAC Metal Angle Clip	GTW - Metal Washers	apolo GT-3 Deluxe Cable Tie Mount	apolo GT-5 Deluxe Cable Tie Mount	apolo Conduit Saddle	apolo Self Locking Pipe Clamp	apolo Channel Strut	GTI-140C Insulation Fasteners
ICCONS® GAS Tools																	
GT-3 Long & Short Track																	
GT-6 Long & Short Track																	
GTI-140C																	
ICCONS® PX Tools																	
PX375																	
PX350																	
PX60M																	
PX Insulation Kit																	
Powers® GAS Tools																	
Trak-It® C3																	
Trak-It® C4-EX																	
Trak-It® C5																	
Powers® PA Tools																	
PAT660																	
PA3500EX																	
P3X																	
Ramset™ PA Tools																	
* FrameBoss™																	
* FrameMaster™ TS750P																	
* FormMaster™																	
* TyMaster™																	
* JobMaster™																	
Ramset™ Gas																	
* TrakFast™ 800																	
* TrakFast™ TF1100 / 1200																	
* InsulFast™ GT																	
* CableMaster™ 800																	
* CableMaster™																	
* TrakMaster™																	
Hilti DX																	
DX2																	
DX 36																	
DX351 MX																	
DX351 M+E																	
DX460 IE																	
DX460-F8																	
DX460 MX 72																	
DX462 HM																	
DX A40/A41																	
PAGE No.	85	86	85	85	85	85	86	86	87	87	87	88	88	89	89	89	91

* Are registered trade marks of ITW. - Trak-It® is a registered trade mark of Stanley Black & Decker. - Hilti is a registered trademark of HiltiCorp., Schaan

Product Name	Image	99	99	99	94	94	94	95	95	95	96	96	96	96	97	97	97	98	98	98	98	
PX-LS Load Strip .27 Caliber		Green	Green																			
PXLD - Load Disk .25 Caliber			Green	Green																		
PSV - Load Single .22 Caliber				Green																		
PXC 8mm Head Collated Drive Pin				Green																		
PX9C 9mm Head Collated Drive Pin				Green																		
PX Rubber Spring					Green																	
PXS - 8mm Single Drive Pins					Green	Green	Green	Green	Green	Green	Green	Green	Green	Green	Green	Green	Green	Green	Green	Green	Green	Green
PXSC - 8mm Head Ballistic Point Pin					Green	Green	Green	Green	Green	Green	Green	Green	Green	Green	Green	Green	Green	Green	Green	Green	Green	Green
PHV - 6mm Head Drive Pin																						
PXTH - Top Hat Assembly					Green	Green	Green	Green	Green	Green	Green	Green	Green	Green	Green	Green	Green	Green	Green	Green	Green	Green
PXW - 22mm Metal Washer Ass.					Green	Green	Green	Green	Green	Green	Green	Green	Green	Green	Green	Green	Green	Green	Green	Green	Green	Green
PXWTH - 22mm Metal Washer Top Hat					Green	Green	Green	Green	Green	Green	Green	Green	Green	Green	Green	Green	Green	Green	Green	Green	Green	Green
PXIW - 36mm Metal Insulation Washer					Green	Green	Green	Green	Green	Green	Green	Green	Green	Green	Green	Green	Green	Green	Green	Green	Green	Green
PXIF - Insulation Fasteners															Green							
PXCC - Angle Clip															Green	Green	Green	Green	Green	Green	Green	Green
PXCCSC - Angle Clip Ballistic Point															Green	Green	Green	Green	Green	Green	Green	Green
PXTR - M10 Threaded Rod Hanger																		Green	Green	Green	Green	Green
PXCON - Conduit Clip Metal Assembly																		Green	Green	Green	Green	Green
PXTCT - Cable Tie Assembly																		Green	Green	Green	Green	Green
PACCNP - Angle Clip																						Green



ON-SITE SUPPORT

ICCONS® rapidly expanding national site support team is constantly working to improve training and education for contractors, project managers and design engineers etc.

This program is an exciting new initiative driven from ICCONS® head office and offers;

- Product demonstrations
- Fixing application advise
- Product installation training and certification
- On-site product testing
- Trade show events

PRODUCT SPECIFICATION

Engineering service is a key focus for ICCONS®. Supporting engineers and designers with tenders, problem solving and providing design consultation is the ICCONS® philosophy. ICCONS® has a national team of engineers available for design advice and site support.

Our engineering team is also available for presentation seminars (conducted at your office/facility) which deliver a comprehensive insight into the unique ICCONS® product range, latest standards and industry developments.



TESTING LABORATORY

ICCONS® in-house test laboratory located in Melbourne, Australia provides testing capabilities in accordance with current Australian standards as well as bespoke testing for project specific applications. Testing equipment is independently maintained and calibrated by Australian NATA accredited laboratories. Extensive testing is also undertaken in partnership with ICCONS® sister company, SYMPAFIX® based in Europe and in accordance with European Technical Guidelines.



USING PGM CERTIFIED DRILL BITS

European Technical Approvals / Assessments (ETA's) for anchors and their installation demands the use of suitable drill bits. Suitable drill bits can be identified under site conditions by simply looking for the PGM mark on the drill bit. The PGM mark is a symbol of quality and provides the installer with a correctly drilled hole for safe anchor installation.



INNOVATIVE SOFTWARE - ANCHOR DESIGN MADE EASY

- Innovative 3d visual user interface, ETAG-001 compliant
- SEISMIC DESIGN under earthquake loads according to ETAG-001, Annex E, TR045
- Finite element analysis steel baseplate design

ICCONS® DesignFiX Software is simple, intuitive and FREE to DOWNLOAD anchor design program for Design Engineers, Project Managers, Site Engineers and End Users. Complex mechanical or chemical heavy duty anchor arrangements can be calculated in minutes. All designs are ETA based and qualify under the newly released **AS 5216:2018** and **SATS101:2015** which is now directly referenced in the **2016 National Construction Code**. With input Freedom & 3D user Interface ICCONS® DesignFiX offers complete freedom to select an anchor pattern and base plate configuration, as well as the position and direction of load combinations. Changes are made directly into the 3D user interface.

Anchor Type Comparison

ICCONS® DesignFiX displays the usability of the various anchor types (according to ETAG-001, Annex C, TR029), including the values for each load type. This allows you to compare the calculation result of the different anchor types in a single easy to read panel.

Optimum BIS Injection System Anchorage Depth when selecting a BIS Injection Mortar.

ICCONS® DesignFiX allows for the automatic calculation of the most effective anchorage depth, taking in consideration the minimal and maximum values of the ETA.

The integrated FEM-Calculation Method (Finite Element Method) in ICCONS® DesignFiX allows you to calculate the base plate thickness based upon the stresses in the base plate combination with the base plate configuration.



www.iccons.com.au





ANCHORING



First in Safety, First in Seismic C2 Certification

SAFE INSTALLATION

Optimal expansion guaranteed by the coupling of the cone and body



UNIFORM EXPANSION

Single piece three expanding segments

ANTI-ROTATION

The special bush shape prevents rotation



APPLICATIONS:

Steel/Aluminium constructions which require a high certified level of safety

Suspended applications

Data centres & high risk applications

Heavy duty machinery

Airports & transport infrastructure

Structural applications in seismic areas

Bridging & tunnelling

Public infrastructure

ATS EVO





ANCHORING



FRULSIDER ATS-evo YOUR FIXING FACTORY

ATS-evo S - Hex head bolt Carbon Steel Class 8.8 Zinc Clear



Made in Italy

ZINC

INTERNAL

3DG

EXTERNAL



Part No.	Part No.	Description	mm	Clearance /mm	mm	Thread / mm	Socket / mm	qty
ATSe10070 (79302b10070)		10 x 70mm (M6 Bolt)	10	12	10	70	10	50
ATSe10080 (79302b10080)		10 x 80mm (M6 Bolt)			20	80		50
ATSe10110 (79302b10110)		10 x 110mm (M6 Bolt)			50	110		50
ATSe12080 (79302b12080)		12 x 80mm (M8 Bolt)	12	14	10	80	13	25
ATSe12090 (79302b12090)		12 x 90mm (M8 Bolt)			20	90		25
ATSe12120 (79302b12120)		12 x 120mm (M8 Bolt)			50	120		25
ATSe15090 (79302b15090)		15 x 90mm (M10 Bolt)	15	17	10	90	17	20
ATSe15100 (79302b15100)		15 x 100mm (M10 Bolt)			20	100		20
ATSe15130 (79302b15130)		15 x 130mm (M10 Bolt)			50	130		20
ATSe15180 (79302b15180)		15 x 180mm (M10 Bolt)			100	180		20
ATSe18090LW*	ATSe18090LWG*	18 x 90mm (M12 Bolt) NEW	18	20	12	90	22	20
ATSe18110 (79302b18110)		18 x 110mm (M12 Bolt)			10	110	19	20
ATSe18125 (79302b18125)		18 x 125mm (M12 Bolt)			25	125		20
ATSe18150 (79302b18150)		18 x 150mm (M12 Bolt)			50	150		20
ATSe18200 (79302b18200)		18 x 200mm (M12 Bolt)			100	200		20
ATSe24125 (79302b24125)		24 x 125mm (M16 Bolt)	24	26	10	125	24	10
ATSe24140 (79302b24140)		24 x 140mm (M16 Bolt)			25	140		10
ATSe24165 (79302b24165)		24 x 165mm (M16 Bolt)			50	165		10
ATSe24215 (79302b24215)		24 x 215mm (M16 Bolt)			100	215		10
ATSe28160# (79302b28160)		28 x 160mm (M20 Bolt)	28	31	10	160	30	4
ATSe28180 (79302b28180)		28 x 180mm (M20 Bolt)			30	180		4
ATSe28210 (79302b28210)		28 x 210mm (M20 Bolt)			60	210		4
ATSe28250# (79302b28250)		28 x 250mm (M20 Bolt)			100	250		4
ATSe32180 (79302b28210)		32 x 180mm (M24 Bolt)	32	35	10	180	36	4
ATSe32200 (79302b32200)		32 x 200mm (M24 Bolt)			30	200		4
ATSe32230 (79302b28230)		32 x 230mm (M24 Bolt)			60	230		4

*Part not Included in European Technical Assessment (ETA).
#Contact ICCONS for availability - lead times may apply



FRİULSIDER
YOUR FIXING FACTORY

ATS-evo

THIN PANEL ANCHOR

HEAVY DUTY Safety Anchor for THIN precast Concrete panels

- Designed for use in thin precast concrete panels
- M12 hex head class 10.9 bolt
- High strength large diameter structural washer (O.D. 44mm)
- Tested in Australian precast concrete
- Independently tested by Swinburne University of Technology (report ref. SSL18-10036)
- Designed for minimum precast concrete panel thickness of 125mm
- Available in zinc and 3DG corrosion resistant coating

For full details refer to ICCONS Technical brochure

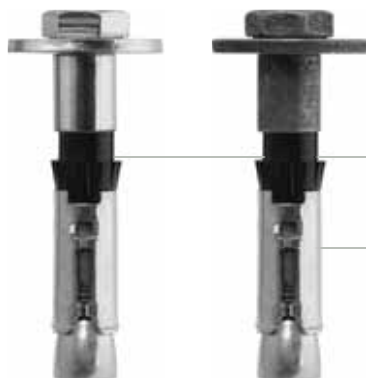

ZINC INTERNAL 3DG EXTERNAL

Part No.	Part No.	Description	mm	Clearance /mm	mm	Length /mm	Socket / mm	qty
ATSeS18090LW	ATSeS18090LWG	18 x 90mm (M12 Bolt) NEW	18	20	12	90	22	20

90mm
Ø18

125mm
THIN PANEL MIN.

easy identification
Clear head and body ID and data

ZINC
clear

corrosion resistant
Carbon steel

3DG
COATING

High corrosion resistant zinc coating

FRİULSIDER YOUR FIXING FACTORY **ATS-evo** THIN PANEL ANCHOR

Carbon Steel Class 10.9 Zinc Clear

Carbon Steel Class 10.9 Corrosion Resistant / 3DG Coating



Made in Italy

NEW





ANCHORING



FRIULSIDER ATS-evo

ATS-evo SK - Countersunk bolt hex socket Carbon Steel Class 8.8 Zinc Clear



Made in Italy

ZINC INTERNAL



Part No.	Description	mm	Clearance /mm	mm	mm	mm	mm	mm	qty
ATSeSK10070	10 x 70mm (M6 Bolt) (79303b10070)	10	12	15	70	17	5	50	
ATSeSK10080	10 x 80mm (M6 Bolt) (79303b10080)			25	80			50	
ATSeSK12080	12 x 80mm (M8 Bolt) (79303b12080)	12	14	16	80	21	6	25	
ATSeSK12090	12 x 90mm (M8 Bolt) (79303b12090)			26	90			25	
ATSeSK15090	15 x 90mm (M10 Bolt) (79303b15090)	15	17	17	90	26	7	20	
ATSeSK15100	15 x 100mm (M10 Bolt) (79303b15100)			27	100			20	
ATSeSK18125	18 x 125mm (M12 Bolt) (79303b18125)	18	20	33	125	31	8	20	

PBA - Heavy Duty Panel Brace Anchor

PBA Carbon Steel Class 8.8 Zinc Yellow



ZINC INTERNAL / TEMPORARY EXTERNAL

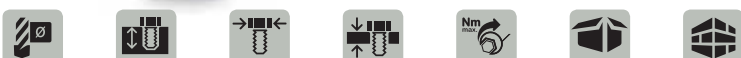

Part No.	Description	mm	mm	mm	mm	Nm	qty	qty
PBA20115	M14 x 115mm	20	95	30	20	150	25	75



32 Teeth High Torque Ratchet Mechanism. Small & Round Ratchet Head Ideal Where There Is Limited Access



Accurate Torque Setting With Two-Window reading Scales



To Adjust & Lock Torque Setting - Pull-Out, Twist & Push In Bottom Adjuster Knob.

Industrial Torque Wrench

- Calibration certificate under international standard.
- Micro adjustable
- Forward / Reverse Ratchet function
- 1/2" drive
- Torque Range 40 - 200 Nm
- Protective storage case

NEW



Part No.	Description	Nm	qty	qty
ATW40200	1/2" drive adjustable torque wrench - 520mm long	40 - 200 Nm	1	10



3DG COATING

Corrosion protection

COATING THICKNESS

High resistance zinc coating with reduced thickness, that does not interfere with the thread geometry, guaranteeing the correct body/nut coupling.

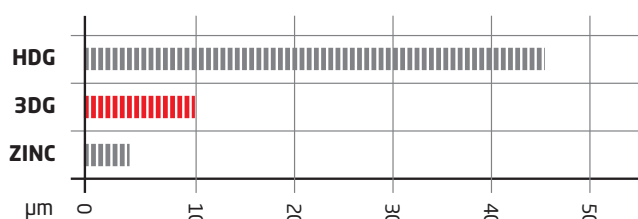

ANTI-SCRATCH

Special self-healing anti-scratch external finish that guarantees the complete fixing coating even in the event of minor impacts with other metallic bodies.



RESPECT FOR THE ENVIRONMENT

It complies with the RoHS directive 2011/65/EU, the European CE Reach regulation 1907/2006, and is free from Chromium VI.



MAX CORROSION RESISTANCE

Corrosion resistance in Salt Spray up to 1000 hours (min), resistance depending on the geometry of the fixing).

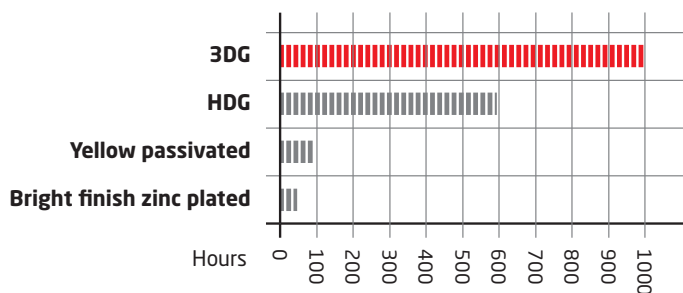

CORROSIVITY CATEGORIES ACCORDING TO ISO 9223			STEEL BRIGHT FINISH ZINC PLATED 5µm ISO4042	STEEL 3DG	STAINLESS STEEL A4 (wr.1.4404 EN10088)
C5-I	very high	Industrial			■
C5-M	very high	Marine			■
C4-I	high	Industrial			■
C4-M	high	Marine		■	■
C3	medium	Industrial-Marine-Urban		■	■
C2	low	Urban		■	■
C1	very low	Rural	■	■	■

- C5-I** = industrial environments with high air pollution (sulfur dioxide-chloride-etc);
- C5-M** = marine environment with very high salinity and very close to the sea <0.2 km;
- C4-I** = industrial environment with high sulfur dioxide pollution;
- C4-M** = coastal areas with high salinity, distance from the sea 0,2-1 km;
- C3** = urban or industrial environment with low sulfur dioxide pollution, coastal areas with moderate salinity, distance from the sea 1-3 km;
- C2** = urban environment contaminated mainly from densely populated areas with no significant industrial activity, distance from the sea > 3 km;
- C1** = rural non-contaminated environment, mainly natural areas, distance from the sea > 20 km.

■ Partially suitable applications ■ Suitable applications

The environmental assessment must be carried out by designers and/or competent personal, the influence of the above factors must be considered in the use of the fixings shown in the table, and therefore suitable protective and design-construction factors must be implemented.



LOW CORROSIVITY RURAL ENVIRONMENTS



MEDIUM CORROSIVITY URBAN AND SUBURBAN ENVIRONMENTS



FM753 CRACK

▶ HEAVY DUTY THROUGH ANCHOR WITH SEISMIC CERTIFICATION



3DG COATING Glossy Finish *P27*

FM753 3DG



3DG COATING Matt Finish *P28*

FMX5

▶ MULTI EXPANSION LONG PLUG



3DG COATING Matte Finish *P57*



3DG COATING Matt Finish *P58 - 59*



Maximum performance,
with seismic certification C2.



SOLID EXPANSION

Stainless steel clip
with proprietary design



GREATER STABILITY

Nine gripping dents
for undercutting
action into concrete



**3DG
COATING**

1000 h

Special anti-corrosion coating
1000 hours in salt spray test

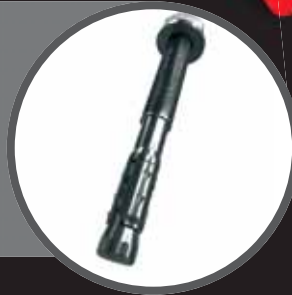

APPLICATIONS:

Steel/Aluminium constructions which require a high certified level of safety

Suspended applications

Data centres & high risk applications

Heavy duty machinery

Airports & transport infrastructure

Structural applications in seismic areas

Bridging & tunnelling

Public infrastructure



FM753 CRACK





ANCHORING



FRIULSIDER FM753® CRACK

■ Carbon Steel Class 9.8 - Corrosion Resistant 3DG



■ Stainless Steel 316 INOX A4



Made in Italy

3DG EXTERNAL

316 SS EXTERNAL



Part No.	Part No.	Description	mm	Clearance /mm	mm	Thread / mm	Socket / mm	qty	qty
FM753C08068G (75350b08068)	FM753C08068SS (75350008068)	M8 x 68mm	8	9	4	30	13	100	400
FM753C08075G (75350b08075)	FM753C08075SS (75350008075)	M8 x 75mm		9	10	30	13	100	400
FM753C08090G (75350b08090)	FM753C08090SS (75350008090)	M8 x 90mm		9	25	40	13	100	400
FM753C08115G (75350b08115)	FM753C08115SS (75350008115)	M8 x 115mm		9	50	60	13	100	400
FM753C08135G (75350b08135)	FM753C08135SS (75350008135)	M8 x 135mm		9	70	80	13	100	400
FM753C08165G (75350b08165)	FM753C08165SS (75350008165)	M8 x 165mm		9	100	80	13	50	200
FM753C10090G (75350b10090)	FM753C10090SS (75350010090)	M10 x 90mm	10	12	10	40	17	50	200
FM753C10105G (75350b10105)	FM753C10105SS (75350010105)	M10 x 105mm		12	25	55	17	50	200
FM753C10115G (75350b10115)	FM753C10115SS (75350010115)	M10 x 115mm		12	35	55	17	50	200
FM753C10135G (75350b10135)	FM753C10135SS (75350010135)	M10 x 135mm		12	55	85	17	50	200
FM753C10155G (75350b10155)	FM753C10155SS (75350010155)	M10 x 155mm		12	75	85	17	50	200
FM753C10185G (75350b10185)	FM753C10185SS (75350010185)	M10 x 185mm		12	105	85	17	25	100
FM753C12110G (75350b12110)	FM753C12110SS (75350012110)	M12 x 110mm	12	14	10	65	19	50	200
FM753C12120G (75350b12120)	FM753C12120SS (75350012120)	M12 x 120mm		14	20	65	19	50	200
FM753C12145G (75350b12145)	FM753C12145SS (75350012145)	M12 x 145mm		14	45	85	19	25	100
FM753C12170G (75350b12170)	FM753C12170SS (75350012170)	M12 x 170mm		14	70	85	19	25	100
FM753C12200G (75350b12200)	FM753C12200SS (75350012200)	M12 x 200mm		14	100	85	19	25	100
FM753C16130G (75350b16130)	FM753C16130SS (75350016130)	M16 x 130mm	16	18	10	65	24	20	80
FM753C16150G (75350b16150)	FM753C16150SS (75350016150)	M16 x 150mm		18	30	85	24	20	80
FM753C16185G (75350b16185)	FM753C16185SS (75350016185)	M16 x 185mm		18	60	85	24	20	80
FM753C16220G (75350b16220)	FM753C16220SS (75350016220)	M16 x 220mm		18	100	85	24	15	60



ANCHORING



FRULSIDER FM753[®] 3DG

Carbon Steel Class 5.8 - Corrosion Resistant 3DG



3DG
COATING



NEW

3DG EXTERNAL



Part No.	Description	mm	Clearance /mm	mm	Thread / mm	Socket / mm	qty	qty
FM75320170G (75320c20170)	M20 x 170mm	20	22	30	60	30	10	40
FM75320215G (75320c20215)	M20 x 215mm	20	22	75	60	30	10	40



SYMPAFIX[®] TB1-Plus Thru-Bolt

Carbon Steel Class 5.8 Zinc Clear



ZINC INTERNAL



Part No.	Description	mm	mm	mm	qty	qty
S-TB1+08060	8 x 60mm (70550)	8	55	5	100	400
S-TB1+08075	8 x 75mm (70552)			20	100	400
S-TB1+08105	8 x 105mm (70558)			50	100	400
S-TB1+10085	10 x 85mm (70562)	10	75	5	50	200
S-TB1+10090	10 x 90mm (70564)			10	50	200
S-TB1+10120	10 x 120mm (70570)			40	50	200
S-TB1+12090*	12 x 90mm (70576)	12	75	5	50	200
S-TB1+12100*	12 x 100mm (70578)			15	50	200
S-TB1+12135*	12 x 135mm (70582)			50	25	100
S-TB1+12185*	12 x 185mm (70588)			100	25	100
S-TB1+16125*	16 x 125mm (70594)	16	100	15	20	80
S-TB1+16150*	16 x 150mm (70596)			40	20	80
S-TB1+16210*	16 x 210mm (70600)			100	10	40

* C1 approval applies

- Note Product is subject to lead times, please contact your local ICCONS branch for further details



ANCHORING



SYMPAFIX® TB1-A4-Plus Thru-Bolt

■ Stainless Steel 316 A4



316 SS EXTERNAL

Part No.	Description	mm	mm	mm	qty	qty
TB08075SS	8 x 75mm (71296)	8	60	15	100	400
TB08100SS	8 x 100mm (71298)		60	40	100	400
TB10065SS*	10 x 65mm	10	55	5	100	400
TB10090SS	10 x 90mm (71302)		75	10	50	200
TB10120SS	10 x 120mm		75	40	50	200
TB12080SS*	12 x 80mm	12	70	10	50	200
TB12100SS	12 x 100mm (71308)		85	15	50	200
TB12140SS	12 x 140mm (71310)		85	55	25	100
TB12180SS	12 x 180mm		85	95	25	100
TB16105SS*	16 x 105mm	16	80	10	25	100
TB16125SS*	16 x 125mm		100	15	20	80
TB16140SS*	16 x 140mm		100	30	20	80
TB20125SS*	20 x 125mm	20	100	10	10	40
TB20160SS*	20 x 160mm		120	25	10	40

* Part not included in the approval



Thru-Bolt Stud Anchor

Standard - Carbon Steel Class 5.8 Zinc Clear

Standard - Carbon Steel Class 5.8 Galvanised

ZINC INTERNAL

GAL EXTERNAL



Part No.	Part No.	Description	mm	mm	mm	qty	qty
TB06085		6 x 85mm	6	50	26	100	1000
TB06120		6 x 120mm		50	61	50	500
TB08080	TB08080G	8 x 80mm	8	55	15	50	500
TB08100	TB08100G	8 x 100mm		55	35	50	500
TB10065	TB10065G	10 x 65mm	10	45	10	25	250
TB10090	TB10090G	10 x 90mm		60	17	25	250
TB10120	TB10120G	10 x 120mm		60	47	25	250
TB12080	TB12080G	12 x 80mm	12	60	5	25	250
TB12100	TB12100G	12 x 100mm		60	25	25	250
TB12140	TB12140G	12 x 140mm		80	45	25	150
TB12180	TB12180G	12 x 180mm		80	85	25	100
TB16105	TB16105G	16 x 105mm	16	80	5	25	100
TB16125	TB16125G	16 x 125mm		100	10	25	100
TB16140	TB16140G	16 x 140mm		100	20	25	100
TB16190	TB16190G	16 x 190mm		100	70	25	50
TB20125	TB20125G	20 x 125mm	20	100	5	10	50
TB20160	TB20160G	20 x 160mm		120	20	10	40
TB20200	TB20200G	20 x 200mm		120	60	10	30



ANCHORING

Why choose ICCONS® Screw-bolts?

Whether you need high performing screw-bolts, NCC or for general use, ICCONS® extensive Screw-bolt range has the solution.



Material / Coating	Carbon steel	Stainless Steel	Carbon Steel	Carbon Steel	Stainless Steel	Carbon Steel	Carbon Steel
	ZINC	316 SS	ZINC	GAL	316 SS	ZINC GAL	ZINC GAL
Performance	Heavy Duty	Heavy Duty	Light	Heavy Duty	Heavy Duty	Heavy Duty	Heavy Duty
ETA assessment	✓	✓	✓	✓	✓		
ETA assessment for multiple embedment depths	✓	✓		✓			
NCC Compliant (SA TS 101:2015)	✓	✓	✓	✓	✓		
AS 5216:2018 compliant	✓	✓	✓	✓	✓		
Fire Rated	✓	✓	✓	✓	✓		
Cracked concrete	✓	✓	✓	✓	✓		
Seismic tested	C1	C1					
Available in A4 316 stainless steel		✓			✓		
Available in Galvanised Finish				✓		✓	✓
Suitable for masonry base material	✓	✓		✓	✓	✓	✓
Removable	✓	✓	✓	✓	✓	✓	✓
Ideal for temporary applications						✓	✓
Ideal for non-safety critical applications						✓	✓
Available in low profile aesthetic head finish	Hex Head	Hex / Countersunk / Pan	Hex Head Internal Thread	Hex Head	Hex / Countersunk	Hex Head / Countersunk / Internal Thread	Hex Head / Eye



Serrated Cutting Lead Threads

SYMPAFIX® SB2 Plus Hex Head

High Tensile Boron Steel Galvanised



GAL EXTERNAL

Part No.	Description	mm	mm	mm	Socket / mm	qty	qty
S-SB2+08050G	8 x 50mm (70464)	8	45	5	13	50	400
S-SB2+08075G	8 x 75mm (70466)			30		50	400
S-SB2+10075G	10 x 75mm (70472)	10	50	25	15	50	200
S-SB2+10100G	10 x 100mm (70474)			50		50	200
S-SB2+12100G	12 x 100mm (70480)	12	50	50	16	25	100



ANCHORING

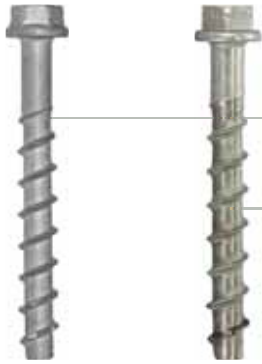

TOGE TSM High Performance Screw-bolts Hex Head

Carbon Steel Zinc Clear

Stainless Steel 316 A4



ZINC INTERNAL 316 SS EXTERNAL



Part No.	Part No.	Description	mm	mm	mm	Socket / mm	qty	qty
TSM06050*	TSM06050SS*	6 x 50mm	6	35	15	13	100	n/a
	TSM06060SS*	6 x 60mm					100	n/a
TSM06080*		6 x 80mm					100	n/a
	TSM08070SS	8 x 70mm	8	45	25	13	50	n/a
TSM08080	TSM08080SS	8 x 80mm					50	n/a
	TSM10090SS	10 X 90mm	10	55	35	15	50	n/a
TSM10100	TSM10100SS	10 X 100mm					50	n/a
	TSM10120SS	10 X 120mm					50	n/a
TSM12110		12 X 110mm	12	65	45	17	25	n/a
TSM14150		14 x 150mm	14	75	75	21	25	n/a

*C1 Seismic approval does not apply to size 6mm

C1 Seismic approval only valid for the following embedment depths: TSM08 - 65mm / TSM10 - 85mm / TSM12 - 100mm / TSM14 - 115mm.



TOGE TSM High Performance Screw-bolts Countersunk

Stainless Steel 316 A4



316 SS EXTERNAL

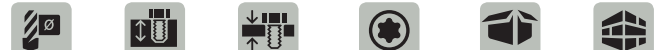

Part No.	Description	mm	mm	mm	torx drive	qty	qty
TSMC06050SS*	6 x 50mm	6	35	15	TX30 / VZ30	100	n/a
TSMC06065SS*	6 x 65mm					100	n/a
TSMC06085SS*	6 x 85mm					100	n/a
TSMC06105SS*	6 x 105mm					100	n/a
TSMC08080SS	8 x 80mm	8	45	35	TX40 / VZ40	50	n/a
TSMC10090SS	10 X 90mm	10	55	35	TX50 / VZ50	50	n/a

*C1 Seismic approval does not apply to size 6mm

C1 Seismic approval only valid for the following embedment depths: TSM08 - 65mm / TSM10 - 85mm



TOGE TSM High Performance Screw-bolts Pan Head

Stainless Steel 316 A4



316 SS EXTERNAL



Part No.	Description	mm	mm	mm	torx drive	qty	qty
TSMP06050SS	6 x 50mm	6	35	15	TX30 / VZ30	100	n/a
TSMP06060SS	6 x 60mm					100	n/a
TSMP06080SS	6 x 80mm					100	n/a
TSMP06100SS	6 x 100mm					100	n/a



ANCHORING

STAINLESS STEEL

THUNDERBOLT® PRO-XTM

COMPLIES WITH AS 5216:2018

ID stamped flanged Hex head styles available

ID stamped Countersunk head styles available

COMPLIES WITH
AS 5216:2018
FOR
POST-INSTALLED
FASTENINGS

Fastening thread
316 Series Austenitic Stainless Steel
to provide longlife application and
reliable fastening unit.

Carbon Alloy Tapping thread
Unique hardening process
provides good tapping
performance

UNIQUE WELDING TECHNOLOGY



ThunderBolt® Pro-XTM Hex Head



NEW

■ Bi-metal SS 316 A4



316 SS EXTERNAL



Part No.	Description	mm	Drill Depth mm	mm	mm	Socket / mm	ETA Option	qty	qty
SXTM06060SS	6 x 60mm	6	65	55	5	10	n/a	100	400
SXTM06075SS-A	6 x 75mm - Approved		80	70	5		Part 6	100	400
SXTM08070SS-A	8 x 70mm - Approved	8	62	52	18	13	Part 6	80	320
SXTM08090SS-A	8 x 90mm - Approved		95	85	5		Option 1	80	320
SXTM10090SS	10 x 90mm	10	85	75	15	17	n/a	45	180
SXTM10100SS	10 x 100mm		85	75	25		n/a	45	180
SXTM10120SS-A	10 x 120mm - Approved		110	100	20		Option 1	25	150
SXTM12110SS	12 x 110mm	12	105	95	15	19	n/a	30	120
SXTM12125SS-A	12 x 125mm - Approved		130	120	5		Option 1	20	120

ThunderBolt® Pro-XTM Csk Head



NEW

■ Bi-metal SS 316 A4



316 SS EXTERNAL



Part No.	Description	mm	Drill Depth mm	mm	mm	mm	ETA Option	qty	qty
SXTMCS06080SS-A	6 x 80mm - Approved	6	80	70	10	T40	Part 6	100	400
SXTMCS08095SS-A	8 x 95mm - Approved	8	95	85	10	T45	Option 1	80	320



ANCHORING

Stamped Cold Forged head for fast and accurate anchor identification.

Industry-Standard Large hex head ensures secure connection.

Underside of head features Anti-rotation design to resist loosening and improves Dynamic Load Performance.

Chamfered tip centres anchor and aids installation.

High Tensile
Boron Steel
Zinc Yellow

High Tensile
Boron Steel
Galvanised

10/60

15° HI-LOW double lead thread has been optimised to provide fast installation while maintaining a high level of thread engagement.

10 Hardened Thread Cutting Teeth reduce installation torque and ensure deep thread formation in the hardest base materials.

Asymmetric thread profile provides unparalleled "bite" in concrete.

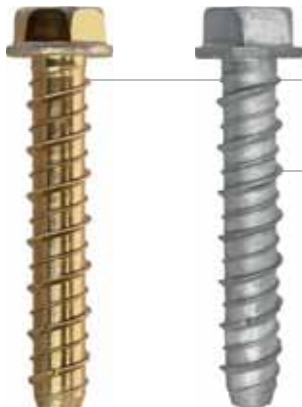

ThunderBolt® Pro Hex Head

■ Standard - High Tensile Boron Steel Zinc Yellow

■ Standard - High Tensile Boron Steel Galvanised

**NEW
SIZES**



for 8 to 16mm sizes only

ZINC INTERNAL		GAL EXTERNAL		mm		mm	mm	Socket / mm	qty	qty
Part No.	Part No.	Description								
SXTB05050	SXTB05050G	5 x 50mm	NEW	5	25	25	8	100	1600	
SXTB06030	SXTB06030G	6 x 30mm	NEW	6	25	5	10	100	1600	
SXTB06050	SXTB06050G	6 x 50mm	NEW		30	20		100	1200	
SXTB06075	SXTB06075G	6 x 75mm	NEW			45		100	600	
SXTB06100	SXTB06100G	6 x 100mm	NEW			55		100	600	
SXTB08050	SXTB08050G	8 x 50mm		8	40	10	13	100	600	
SXTB08060	SXTB08060G	8 x 60mm				20		100	600	
SXTB08075	SXTB08075G	8 x 75mm				35		100	500	
SXTB08100	SXTB08100G	8 x 100mm				60		100	400	
SXTB10060	SXTB10060G	10 x 60mm		10	50	10	17	50	250	
SXTB10075	SXTB10075G	10 x 75mm				25		50	250	
SXTB10100	SXTB10100G	10 x 100mm				50		50	250	
SXTB10120	SXTB10120G	10 x 120mm				70		50	250	
SXTB12075	SXTB12075G	12 x 75mm		12	60	15	19	50	150	
SXTB12100	SXTB12100G	12 x 100mm				40		50	150	
SXTB12120	SXTB12120G	12 x 120mm				60		25	125	
SXTB12150	SXTB12150G	12 x 150mm				90		25	75	
SXTB16100	SXTB16100G	16 x 100mm		16	80	20	24	15	60	
SXTB16150	SXTB16150G	16 x 150mm				70		15	60	



ANCHORING

ThunderBolt® PRO Tie-Down Anchor



■ Standard - High Tensile Boron Steel Zinc Yellow

■ Standard - High Tensile Boron Steel Galvanised



ZINC INTERNAL

GAL EXTERNAL



Part No.	Part No.	Description	mm	metric	mm	Socket / mm	qty	qty
SXTBTD12100	SXTBTD12100G	12 x 100mm	12	M12	45	19	25	100
SXTBTD12150	SXTBTD12150G	12 x 150mm	12	M12	90	19	25	100



ThunderBolt® Pro Countersunk Head

■ Standard - High Tensile Boron Steel Galvanised

NAUTILUS®
EXTEND

DRIVER BIT INCLUDED



GAL EXTERNAL



Part No.	Description	mm	mm	mm	mm	mm	Drive Int Hex	qty	qty
SXTBCS06050G	6 x 50mm	6	25	25	16	6	5mm	100	1200
SXTBCS06075G	6 x 75mm			50				100	600
SXTBCS08060G	8 x 60mm	8	35	15	21	8	6mm	100	600
SXTBCS08075G	8 x 75mm			40				100	500
SXTBCS08100G	8 x 100mm			65				100	400
SXTBCS10060G	10 x 60mm	10	40	20	25	9	8mm	100	400
SXTBCS10075G	10 x 75mm			35				50	300
SXTBCS10100G	10 x 100mm			60				50	300
SXTBCS12075G	12 x 75mm	12	50	25	28	10	10mm	50	200
SXTBCS12100G	12 x 100mm			50				50	150
SXTBCS12150G	12 x 150mm			100				20	120



Black-Tip ThunderBolt® EYE

■ Standard - High Tensile Boron Steel Zinc Yellow

ZINC INTERNAL



Part No.	Description	NEW	mm	mm	mm	qty	qty
SXBEYE08055	8 x 55mm	NEW	8	55	14 int	50	300
SXBEYE12075	12 x 75mm		12	60	20 int	20	120

NOTE: The Thunderbolt®PRO Eyebolt Screwbolt is designed for use in non-safety critical applications only.
The Thunderbolt®PRO Eyebolt Screwbolt is **NOT** designed for use in Fall Arrest Systems or as a lifting anchor.



Black-Tip ThunderBolt® Hex Head

■ Standard - High Tensile Boron Steel Zinc Yellow

■ Standard - High Tensile Boron Steel Galvanised

ZINC INTERNAL

GAL EXTERNAL



Part No.	Part No.	Description	mm	mm	mm	Socket / mm	qty	qty
SXB05050	SXB05050G	5 x 50mm	5	25	25	8	100	1600
SXB06030	SXB06030G	6 x 30mm	6	25	5	10	100	1600
SXB06050	SXB06050G	6 x 50mm		30	20		100	1200
SXB06075	SXB06075G	6 x 75mm			45		100	600
SXB06100	SXB06100G	6 x 100mm			55		100	600
SXB08050	SXB08050G	8 x 50mm	8	40	10	13	100	600
SXB08060	SXB08060G	8 x 60mm			20		100	600
SXB08075	SXB08075G	8 x 75mm			35		100	500
SXB08100	SXB08100G	8 x 100mm			60		100	400
SXB10060	SXB10060G	10 x 60mm	10	50	10	15	50	300
SXB10075	SXB10075G	10 x 75mm			25		50	300
SXB10100	SXB10100G	10 x 100mm			50		50	200
SXB10130	SXB10130G	10 x 120mm			80		25	150
SXB12075	SXB12075G	12 x 75mm	12	60	15	16	50	200
SXB12100	SXB12100G	12 x 100mm			40		50	150
SXB12150	SXB12150G	12 x 150mm			90		20	120
SXB16100	SXB16100G	16 x 100mm	16	80	20	21	15	90
SXB16150	SXB16150G	16 x 150mm			70		10	60



ANCHORING

Sleeve Anchor Hex Head

■ Carbon Steel Zinc Yellow

■ Carbon Steel Galvanised

■ Stainless Steel 316 A4

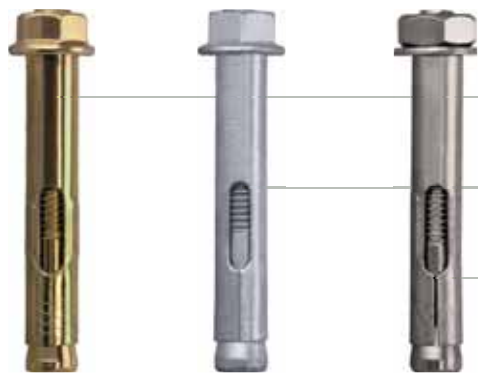

ZINC INTERNAL

GAL EXTERNAL

316 SS EXTERNAL

Part No.	Part No.	Part No.	Description	mm	mm	mm	qty	qty
SA06525			6.5 x 25mm	6.5	20	5	100	1000
SA06535		SA06535SS	6.5 x 35mm		30	5	100	1000
SA06555		SA06555SS	6.5 x 55mm			25	100	1000
SA06575		SA06575SS	6.5 x 75mm			45	100	1000
SA08040	SA08040G	SA08040SS	8 x 40mm	8	35	5	100	1000
SA08065	SA08065G	SA08065SS	8 x 65mm			30	50	500
SA08085	SA08085G	SA08085SS	8 x 85mm			50	50	500
SA10040	SA10040G	SA10040SS	10 x 40mm	10	34	6	50	500
SA10050	SA10050G	SA10050SS	10 x 50mm		40	10	50	500
SA10060	SA10060G	SA10060SS	10 x 60mm			20	50	500
SA10075	SA10075G	SA10075SS	10 x 75mm			35	50	500
SA10095	SA10095G	SA10095SS	10 x 95mm			55	50	400
SA10120			10 x 120mm			80	50	300
SA12060	SA12060G	SA12060SS	12 x 60mm	12	50	10	50	400
SA12075	SA12075G	SA12075SS	12 x 75mm			25	25	250
SA12100	SA12100G	SA12100SS	12 x 100mm			50	25	250
SA12130	SA12130G		12 x 130mm			80	25	200
SA16065	SA16065G		16 x 65mm	16	55	10	25	200
SA16110	SA16110G		16 x 110mm			55	10	100
SA16145			16 x 145mm			90	10	100
SA20075			20 x 75mm	20	60	15	10	100
SA20105			20 x 105mm			45	10	60
SA20150			20 x 150mm			90	10	60

Countersunk Post Head

■ Stainless Steel 316 A4

Countersunk Internal threaded head for use in conversion of stainless steel hex head sleeve anchors to an aesthetic countersunk head style



316 SS EXTERNAL

Part No.	Description	mm	mm	mm	mm	qty	qty
SAPH065SS	M5 Internal Thread (suits 6.5mm SS sleeve anchor)	6.5	12	3.5	M5	100	1000
SAPH08SS	M6 Internal Thread (suits 8.0mm SS sleeve anchor)	8	14	4	M6	100	1000
SAPH10SS	M8 Internal Thread (suits 10.0mm SS sleeve anchor)	10	16	4	M8	100	1000



ANCHORING

Sleeve Anchor Flush Head

■ Carbon Steel Zinc Yellow

■ Stainless Steel 316 A4



ZINC

INTERNAL

316 SS

EXTERNAL



Part No.	Part No.	Description	mm	mm	mm	qty	qty
SAF08045	SAF08045SS	8 x 45mm	8	35	10	100	1000
SAF08070	SAF08070SS	8 x 70mm			35	50	500
SAF08090	SAF08090SS	8 x 90mm			55	50	500
	SAF10040SS	10 x 40mm	10	34	6	50	500
SAF10045		10 x 45mm		40	5	50	500
SAF10055		10 x 55mm			15	50	500
	SAF10060SS	10 x 60mm			20	50	500
SAF10065		10 x 65mm			25	50	500
	SAF10075SS	10 x 75mm			35	50	500
SAF10080		10 x 80mm			40	50	500
	SAF10095SS	10 x 95mm			55	50	400
SAF10100		10 x 100mm			60	50	400
SAF12065		12 x 65mm	12	50	15	50	300
SAF12080		12 x 80mm			30	25	250
	SAF12075SS	12 x 75mm			25	25	250
SAF12105		12 x 105mm			55	25	250
SAF16075		16 x 75mm	16	60	15	25	200
SAF16110		16 x 110mm			50	10	100

Sleeve Anchor Countersunk Head

■ Carbon Steel Zinc Yellow



ZINC

INTERNAL



Part No.	Description	mm	Drive	mm	mm	qty	qty
SACSK065035	6.5 x 35mm	6.5	PH2	30	5	100	1000
SACSK065055	6.5 x 55mm		PH2		25	100	1000
SACSK065075	6.5 x 75mm		PH2		45	100	1000
SACSK065100	6.5 x 100mm		PH2		70	100	1000
SACSK08060	8 x 60mm	8	PH2	35	25	50	500
SACSK08085	8 x 85mm		PH2		50	50	500
SACSK10075	10 x 75mm	10	PH3	40	35	50	500
SACSK10100	10 x 100mm		PH3		60	50	400
SACSK10120	10 x 120mm		PH3		80	50	400



ANCHORING



Sleeve Anchor Suspension, Eye & Hook Bolt

■ Suspension Carbon Steel Zinc Yellow



■ Eye Bolt Carbon Steel Zinc Yellow

■ Hook Bolt Carbon Steel Zinc Yellow

ZINC INTERNAL

ZINC INTERNAL

ZINC INTERNAL



Part No.	Part No.	Part No.	Description	mm	mm	mm	qty	qty
SASUS06525			6.5 x 25mm	6.5	25	7	100	1000
SASUS06535			6.5 x 35mm	6.5	35	7	100	1000
	SAEB0845	SAHB0845	8.0 x 45mm	8.0	45	8	100	1000



Tie Wire Thru-Bolt

■ Carbon Steel Zinc Yellow



ZINC INTERNAL



Part No.	Description	mm	mm	mm	qty	qty
TWTB06060	6.0 x 60mm Tie wire Thru-Bolt	6	40	6	100	1000
TWTB06090	6.0 x 90mm Tie wire Thru-Bolt				100	1000
TWTB06120	6.0 x 120mm Tie wire Thru-Bolt				50	500
TWTB06150	6.0 x 150mm Tie wire Thru-Bolt				100	800



Eyelet Purlin Screw

■ Carbon Steel Zinc Yellow

ZINC INTERNAL



Part No.	Description	mm	mm	qty	qty
EPSN	1/4" - 14 x 22mm Eyelet Purlin Screw with EPDM washer	1.2 - 1.6	4	250	1000



Eyelet Purlin Screw Socket Driver

For use with Eyelet Purlin Screw



Part No.	Description	qty
EPSSD	Eyelet Purlin Screw Socket Driver	1

**NEW****TOGE**
D Ü B E L**TOGE TSO**

Suspension Spring Anchor

 Carbon Steel Zinc Clear

- Easily installs by hand



ZINC INTERNAL



Part No.	Description	mm	mm	qty	qty
TSO06040	6 x 40 suspension spring anchor	6	10	100	n/a

**Tie Wire Post Head** Carbon Steel Zinc Clear

ZINC INTERNAL



Part No.	Description	metric	mm	qty	qty
TWPH10	M10 internal thread post head	M10	10	150	600

**Strike™ Anchor Tie-Wire Ceiling Hanger** Carbon Steel Zinc Clear

ZINC INTERNAL



Part No.	Description	mm	mm	mm	qty	qty
STTW05	5.0 mm Tie Wire Strike™ Anchor	5	30	5.5	100	1000
STTW65	6.5 mm Tie Wire Strike™ Anchor	6.5	25	7	100	1000

* Also referenced on Page 48

**Steel Purlin Vertical Flange Clip**

■ Zinc Yellow

ZINC INTERNAL



Part No.	Description	mm	qty	qty
VFC	1.6 - 2.5mm Steel purlin Vertical flange Clip for steel purlin	1.6 - 2.5	100	2400



ANCHORING

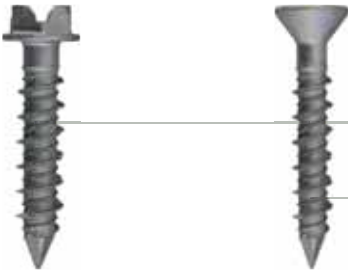

Grabcon® Hex Head & Countersunk Concrete & Masonry Screws

■ Hex Head Grabcon® - Carbon Steel Galvanised

■ Countersunk Grabcon® - Carbon Steel Galvanised

step shank drill bit included in each box

Part No.	Drive	Part No.	Drive	Description	Inch	mm	mm	qty	qty
		GCCSK05032	PH2	5 x 32 Masonry Screw (3/16 x 1-1/4")	*5/32"	25	5	100	2500
		GCCSK05045	PH2	5 x 45 Masonry Screw (3/16 x 1-3/4")				100	2500
		GCCSK05058	PH2	5 x 58 Masonry Screw (3/16 x 2-1/4")				100	1600
		GCCSK05070	PH2	5 x 70 Masonry Screw (3/16 x 2-3/4")				100	1000
GCHX65032	Hex 5/16	GCCSK65032	PH3	6.5 x 32 Masonry Screw (1/4 x 1-1/4")	*3/16"	25	6.5	100	2500
GCHX65045	Hex 5/16	GCCSK65045	PH3	6.5 x 45 Masonry Screw (1/4 x 1-3/4")				100	1600
GCHX65058	Hex 5/16	GCCSK65058	PH3	6.5 x 58 Masonry Screw (1/4 x 2-1/4")				100	1000
GCHX65070	Hex 5/16	GCCSK65070	PH3	6.5 x 70 Masonry Screw (1/4 x 2-3/4")				100	1000
GCHX65083	Hex 5/16	GCCSK65083	PH3	6.5 x 83 Masonry Screw (1/4 x 3-1/4")				100	600
GCHX65100	Hex 5/16	GCCSK65100	PH3	6.5 x 100 Masonry Screw (1/4 x 4")				100	600

*Note step shank drill bit included in each box

Grabcon® SDS Plus 3 Cutter, Imperial Hammer Drill Bits



NEW

Part No.	Description	inch	mm	mm	qty
GCSDS532	5/32" x 100 / 170 - 3 cutter for 5mm Grabcon Anchors NEW	5/32	170	100	1
GCSDS316	3/16" x 150 / 220 - 3 cutter for 6.5mm Grabcon Anchors NEW	3/16	220	150	1



DUSTER PRO



Turn Your Drill Bits into Dustless drill bits

SEE PAGE 177 FOR DETAILS





GRABCON® CONCRETE FRAMING SCREW

FREE!
TX40
Driver bit
Included

Fast, Efficient Bottom Plate Fixing!

- For fixing timber to concrete or brick/ block work
- Domed washer head for high clamping force
- Non-expansion for close to concrete edge
- Can also be used for timber to timber applications
- Fully removable design (nothing left in the concrete)

Performance derived in accordance with AS 1720.1 - 2010 (timber Structures)

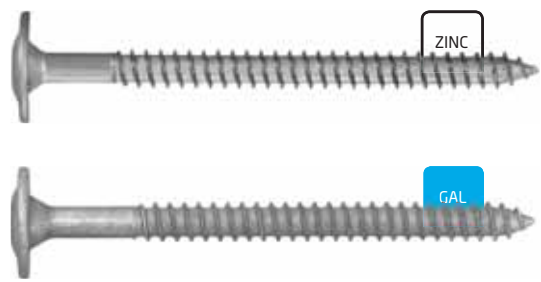

Grabcon® Frame

Grabcon® Concrete Framing Screw - Zinc Clear

Grabcon® Concrete Framing Screw - Galvanised **NEW**



ZINC INTERNAL GAL EXTERNAL

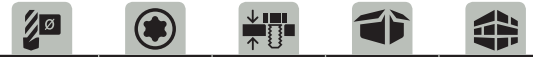

Part No.	Part No.	Description	mm	Torx drive	mm	qty	qty
GCF06102	GCF06102G	6 x 102mm Concrete frame screw	6	T40	up to 45	100	1000

SYMPAFIX® Door & Window Concrete Screws



Carbon Steel Zinc Clear



ZINC INTERNAL



Part No.	Description	mm	mm	Torx drive	qty	qty
SKSZ06062 (99955)	6 x 62mm	6	22	T30	100	1000
SKSZ06072 (70962)	6 x 72mm	6	42	T30	100	400
SKSZ06092 (70964)	6 x 92mm	6	62	T30	100	400
SKSZ06112 (70966)	6 x 112mm	6	82	T30	50	200



SYMPAFIX® Expresse Nails

Ideal for timber Battens to Concrete



Spring Steel Zinc Clear

ZINC INTERNAL



Part No.	Description	mm	mm	qty	qty
SXN06040 (70844)	6 x 40mm	6	10	200	2000
SXN06050 (70846)	6 x 50mm	6	20	200	2000
SXN06060 (70848)	6 x 60mm	6	30	200	2000
SXN06080 (70850)	6 x 80mm	6	50	100	1000

SEISMICALLY QUALIFIED FOR USE IN CRACKED CONCRETE



Dustless anchoring

The Original **BLUE BANGER HANGER**

For Wood Formed Concrete Decks

ICCONS® Pour-in-Place (PIP) inserts are used on wood form poured decks and installed prior to pouring concrete, reducing installation and material costs.

Machined Steel Insert with Large Flanged Head

- Angled ridges protect the head of the insert from rebar during deck work.
- Larger plastic base ensures that the insert is installed flush to the deck to prevent concrete from contaminating the inner threads during the pour.
- UL plenum rated for use in air handling spaces
- Slurry seal safeguards the internal threads during the concrete pour

Machined Steel Insert with Large Flanged Head and Nails

- Provides excellent shear values for overhead attachments.
- Insert installed height of two inches complies with typical design specifications.
- Nails easily break off.

Multiple Internal Threads

- Reduces inventory, each insert can accommodate M8, M10 & M12 threaded rod sizes.
- Allows for threaded rod size changes after inserts are installed.
- Internal threads eliminate the need and cost of couplings.

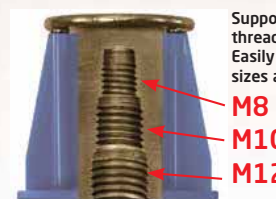

Supports multiple threaded rod sizes. Easily change rod sizes after install.

- M8
- M10
- M12



NEW



ON WOOD FORM, BEFORE HAMMER BLOW

Large plastic base - ensures that the insert is installed flush to deck to prevent concrete from contaminating the inner threads during the pour and prevents accidental knock-overs

WOOD FORM REMOVED, AFTER HAMMER BLOW

Angled ridges protect the head of the insert from rebar during deck work

Nails easily break off with hammer

Slurry seal label safeguards the internal threads from concrete during pour

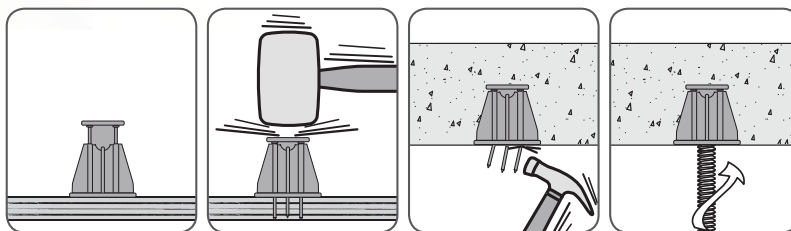

Pour-in-Place Insert - For Wood Form

■ Carbon Steel Zinc Yellow



Part No.	Description		metric	qty
BBPIP081012	Multi Thread Pour-In Place Deck Inserts (for wood form concrete deck)	NEW	M8, M10 & M12	100

Bazooka PIP Magnetic Installation tool

Ergonomic stand up installation tool



Part No.	Description	qty
BBCEA-PIPINSTALL1	1050mm Bazooka PIP installation tool	1





The Original **BLUE BANGER HANGER**

For Pre-Poured Concrete Steel Decks

ICCONS® Steel Deck Inserts (SDI) are installed prior to pouring, reducing installation and material costs and increasing strength values. Ideal for gravity & seismic anchorage!



Machined Steel Insert with Large Flanged Head

- Provides excellent shear values for overhead attachments.
- Patented grooved insert body prevents component separation even if the flute is broken off prior to pour.
- Fully cracked concrete tested for vertical and dynamic seismic loading.
- Backed by: ICC Report ESR-3599 granted under AC446.

Multiple Internal Threads

- Reduces inventory, each insert can accommodate M8, M10 & M12 threaded rod sizes.
- Allows for threaded rod size changes after inserts are installed.
- Internal threads eliminate the need and cost of couplings.

Three Inch Blue Plastic Sleeve

- Keeps internal threads clean.
- Extended length makes insert easy to locate even with fireproofing on deck underside.
- Plastic sleeve provides guidance to align threaded rod with matching internal female threads.
- UL plenum rated for use in air handling spaces.



1) Drill It

2) Bang It

For use in Bondek®, Stramit Condeck HP® & Other metal deck composite profiles

Supports multiple threaded rod sizes. Easily change rod sizes after install.

M8
M10
M12

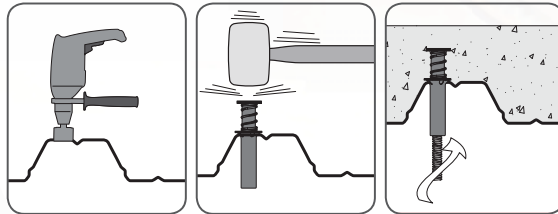

NEW



ZINC



Steel Deck Insert - For Metal Form

■ Carbon Steel Zinc Yellow



Part No.	Description		metric	qty
BBSDI081012	Multi Thread Steel Deck Inserts (for metal form concrete deck)	NEW	M8, M10 & M12	100

Steel Deck Insert Installation tool



Ergonomic stand up installation tool



Part No.	Description	qty
BBCEA-SDDHS1	600mm deck driller with 21mm (13/16") hole saw	1
BBCEA-SDDSB4	600mm deck driller with step drill bit 3/16 to 7/8"	1



ANCHORING



NEW

apolo SA plus Lip Drop-in Anchor

Carbon Steel Zinc Clear



ZINC INTERNAL

Part No.	Description	mm	mm	metric	qty	qty
DLPM1025-A	M10 x 25mm Lip Drop-in anchor - Approved	12	27	M10	50	500



Lip Drop-in Anchor

Carbon Steel Zinc Clear

Carbon Steel Zinc Clear
Bucket Includes 2 x short drill bits & 1 x setting tool.

ZINC INTERNAL

ZINC INTERNAL

Part No.	Part No.	Description	mm	mm	metric	qty	qty
DLPM1030		M10 x 30mm Lip Drop-in anchor	12	32	M10	50	500
	DLPM1030BK	M10 x 30mm Bucket				500	1000
	DLPM1030BK-SDS	M10 x 30mm Bucket with SDS Plus setting tool				500	1000
DLPM1040		M10 x 40mm Lip Drop-in anchor	12	42	M10	50	400
	DLPM1040BK	M10 x 40mm Bucket				500	1000
DLPM1225		M12 x 25mm Lip Drop-in anchor	15	27	M12	50	300
DLPM1250		M12 x 50mm Lip Drop-in anchor	15	52	M12	50	300
	DLPM1250BK	M12 x 50mm Bucket				200	400

Lip Drop-in Setting Tool



For use with Lip Drop-In Anchors & standard non-lip Drop-In Anchors. Use of setting tool is necessary for the correct installation of Drop-in Anchors

Part No.	Description	qty
DLST1030	M10 x 25mm & M10 x 30mm setting tool - Soft grip	1
DLST1040	M10 x 40mm setting tool - Soft grip	1
DLST1225	M12 x 25mm setting tool - Soft grip	1
DLST1250	M12 x 50mm setting tool - Soft grip	1

SDS PLUS Drill Bits & Setting Tool



SDS Plus Drill Bits for use with Lip Drop-In Anchors.



Setting tool Kit for use with M10 x 25 & M10 x 30 Lip Drop-in Anchors only

Part No.	Description	qty
DLSDS1245	12 x 45mm SDS Drill bit for M10 x 25 & M10 x 30 mm Lip Drop-in	1
DLSDS1560	15 x 60mm SDS Drill bit for M12 x 50 mm Lip Drop-in	1
DLSDS-ST1030	SDS setting tool kit for 10 x 25mm & 10 x 30mm Lip Drop-in, includes: 1 x 45mm Drill Bit, 1 x Setting Tool Adaptor	1



SYMPAFIX® Di-Plus Drop-in Anchor

☐ Carbon Steel Zinc Clear



ZINC INTERNAL



Part No.	Description	mm	mm	metric	qty	qty
DM08-A* (70780)	M8 x 30mm Drop-in anchor - Approved	10	32	M8	100	800
DM10-A (70782)	M10 x 40mm Drop-in anchor - Approved	12	42	M10	100	800
DM12-A (70784)	M12 x 50mm Drop-in anchor - Approved	16	52	M12	100	400

*Lead times may apply



Standard Drop-in Anchor

■ Carbon Steel Zinc Yellow

■ Stainless Steel 316 A4

ZINC INTERNAL

316 SS EXTERNAL



Part No.	Part No.	Description	mm	mm	metric	qty	qty
DM06		M6 x 25mm Drop-in anchor	8	27	M6	100	1000
DM08	DM08SS	M8 x 30mm Drop-in anchor	10	32	M8	100	1000
DM10	DM10SS	M10 x 40mm Drop-in anchor	12	42	M10	50	500
DM12	DM12SS	M12 x 50mm Drop-in anchor	15	52	M12	50	400
DM16	DM16SS	M16 x 65mm Drop-in anchor	20	67	M16	25	100
DM20		M20 x 80mm Drop-in anchor	25	82	M20	25	50

Drop-in Setting Tool



For use with standard non-lip Drop-In Anchors. Use of setting tool is necessary for the correct installation of Drop-in Anchors



Part No.	Description	qty
DST06	Suits M6 Standard Drop-In anchors	1
DST08	Suits M8 Standard Drop-In anchors	1
DST10	Suits M10 Standard Drop-In anchors	1
DST12-25	Suits M12 for 25mm Lipped Drop-In anchors	1
DST12	Suits M12 Standard Drop-In anchors	1
DST16	Suits M16 Standard Drop-In anchors	1
DST20	Suits M20 Standard Drop-In anchors	1



ANCHORING



TSMIM06055ZG only



TOGE TSM IM



Carbon Steel Zinc Grey



ZINC GREY INTERNAL ZINC GREY INTERNAL GAL



Part No.	Part No.	Part No.	Description	mm	mm	metric	metric	mm	qty
TSMIM06055ZG (210 060 600)			6 X 55 Hanger (M8/M10 internal thread)	6	60	M8 / M10		13	50
	TSMB06055ZG (355 006 055)		6 X 55 Hanger (M8 External thread)	6	60		M8	10	100
		CPLRM8-M12	M8 to M12 coupler nut for M12 Rod Hanging			M8 to M12		16	100



NEW

ThunderBolt® Pro-XTM Rod Hanger

Carbon Steel Zinc Clear



ZINC INTERNAL



Part No.	Description	mm	mm	metric	mm	qty	qty
SXTM-IM06057	6 X 57 ETA Rod Hanger (M10)	6	65	M10	13	100	400



Hangerz™ for Concrete

Carbon Steel Zinc Clear



ZINC INTERNAL



Part No.	Description	mm	mm	metric	mm	qty	qty
HZCVM10	M10 x 40mm Rod Hanger for Concrete	6	46	M10	13	100	500
HZCVM10-BUCKET	Hangerz™ Concrete M10 500 PCE - (includes 3 x Drill Bits, 1 x Socket, 1 x Sleeve)					500PCE	1



Hangerz™ For Concrete Socket Driver & Adaptor

Socket Driver for use with Hangerz™ for Concrete

Drill bit & Adaptor for use with Hangerz™ for Concrete

CONCRETE



Part No.	Part No.	Description	qty
HZCM10-D		Hangerz™ Socket Driver for Concrete M10 & ThunderboltPro XTM Hanger	1
	HZ6MD-D	Hangerz™ SDS Driver Adaptor	1
	HZ6MD	Hangerz™ SDS Drill 6mm x 150mm	1



ANCHORING



Hangerz™ for Steel

Side Mount Zinc Clear

Vertical Mount Zinc Clear

Socket Driver for use with Hangerz™ for Steel / Timber

ZINC INTERNAL

ZINC INTERNAL



Part No.	Part No.	Part No.	Description	metric	mm	qty	qty
HZSSM10	HZSVM10		M10 Rod Hanger for steel substrates	M10	1.0 - 3.0	100	500
		HZSM10D	Hangerz™ Socket Driver for Steel M10			1	



Hangerz™ for Timber

Vertical Mount Zinc Clear

Socket Driver for use with Hangerz™ for Timber / Steel

ZINC INTERNAL



Part No.	Part No.	Description	metric	mm	qty	qty
HZTV25M10		M10 x 25mm Rod Hanger for timber substrates	M10	25	100	500
HZTV50M10		M10 x 50mm Rod Hanger for timber substrates NEW	M10	50	100	500
	HZSM10D	Hangerz™ Socket Driver for timber M10			1	n/a

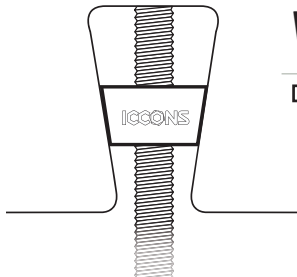

Wedge-Nut

For use in Bondek® Profile - Zinc Clear

ZINC INTERNAL



Part No.	Description	metric	qty	qty
WNM6	M6 Nut For Bondek®	M6	100	1000
WNM10	M10 Nut For Bondek®	M10	100	1000



NEW

Beam Clamp

Rod Hanger



ZINC INTERNAL



Part No.	Description	mm	clearance/mm	qty	qty
TKN10 (PKB10 - 0802 680 006)	Beam Clamp M10 Rod Hanger (without thread)	0 - 20	11	50	n/a
TK12 (PK12 - 0802 680 008)	Beam Clamp M12 rod Hanger (without thread)	0 - 26	13	50	n/a



ANCHORING



Strike™ Anchor Tie-Wire Ceiling Hanger

Carbon Steel Zinc Clear

ZINC INTERNAL



Part No.	Description	mm	mm	mm	qty	qty
STTW05	5.0 mm Tie Wire Strike™ Anchor	5	30	5.5	100	1000
STTW65	6.5 mm Tie Wire Strike™ Anchor	6.5	25	7	100	1000

* Also referenced on Page 39



Strike™ Anchor Mushroom Head

Carbon Steel Mechanically Galvanised

Stainless Steel 316 A4

GAL EXTERNAL 316 SS EXTERNAL



Part No.	Part No.	Description	mm	mm	qty	qty
STMH05025G	STMH05025SS	5 x 25mm	5	3	100	2500
STMH05032G	STMH05032SS	5 x 32mm		10	100	2500
STMH05038G	STMH05038SS	5 x 38mm		6	100	2500
STMH05050G	STMH05050SS	5 x 50mm		19	100	1600
STMH65025G		6.5 x 25mm	6.5	3	100	2000
STMH65038G	STMH65038SS	6.5 x 38mm		6	100	1600
STMH65050G	STMH65050SS	6.5 x 50mm		19	100	1000
STMH65063G		6.5 x 63mm		32	100	1000
STMH65075G	STMH65075SS	6.5 x 75mm		44	100	1000
STMH65100G		6.5 x 100mm		68	100	600
STMH10075G		10 x 75mm	10	32	25	400
STMH10100G		10 x 100mm		57	25	300
STMH10125G		10 x 125mm		82	25	250



Strike™ Anchor Formwork Head

Carbon Steel Mechanically Galvanised

GAL EXTERNAL



Part No.	Description	mm	mm	qty	qty
STFW05050G	5 x 50mm	5	18	100	1000
STFW05063G	5 x 63mm		31	100	1000
STFW65063G	6.5 x 63mm	6.5	31	100	1000
STFW65100G	6.5 x 100mm		68	100	600



ANCHORING



Strike™ Anchor Countersunk

■ Carbon Steel Mechanically Galvanised

GAL EXTERNAL



Part No.	Description	mm	mm	qty	qty
STCS05065G	5 x 65mm	5	33	100	1000
STCS05075G	5 x 75mm		43	100	1000
STCS05100G	5 x 100mm		68	100	1000
STCS65038G	6.5 x 38mm	6.5	6	100	1600
STCS65050G	6.5 x 50mm		18	100	1000
STCS65065G	6.5 x 65mm		33	100	1000
STCS65075G	6.5 x 75mm		43	100	1000
STCS65100G	6.5 x 100mm		68	100	600

SYMPAFIX® CA-PLUS

AS 5216:2018 CODE COMPLIANT

- AS 5216:2018 code compliant
- Approved for cracked concrete
- European Technical Assessment (ETA)
- Fire rated performance
- All metal construction
- Tamper resistant head
- Clean, low profile aesthetic appearance



ICCONS® Sympafix CA-Plus is an all metal wedge style anchor that sets by hammer impact, thus sliding the pin down the stem creating an expansive force against the wall of the hole. Ideal for mechanical trades using suspending strap, various hanger systems, through fixings, fire collar mountings etc.

Expansion pin

Hammer impact point

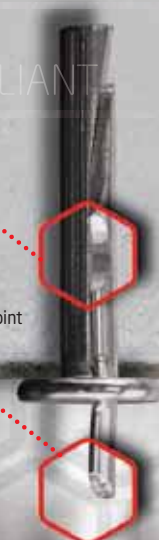

ALL-METAL

SYMPAFIX® CA-Plus Splice Anchor Metal Wedge Anchor

□ Carbon Steel Zinc Clear



ZINC INTERNAL



Part No.	Description	mm	mm	qty	qty
SPZ0635-A (CA-Plus)	6 x 35mm	6	3	200	1600
SPZ0665-A (CA-Plus)	6 x 65mm		33	100	1000



ANCHORING



Nylon Nailin Anchor Countersunk

■ Carbon Steel Zinc Yellow Pin

ZINC INTERNAL



Part No.	Description	mm	mm	qty	qty
NNC05025	5 x 25mm	5	6.5	100	1000
NNC65025	6.5 x 25mm	6.5	6.5	100	1000
NNC65038	6.5 x 38mm		19	100	1000
NNC65050	6.5 x 50mm		32	100	1000
NNC65075	6.5 x 75mm		50	100	1000



Nylon Nailin Anchor Mushroom Head

■ Carbon Steel Zinc Yellow Pin

■ Stainless Steel 304 A2 Pin

ZINC INTERNAL 304 SS EXTERNAL



Part No.	Part No.	Description	mm	mm	qty	qty
NNM05025	NNM05025SS	5 x 25mm	5	6.5	100	1000
NNM05040		5 x 40mm NEW		19	100	1000
NNM65025	NNM65025SS	6.5 x 25mm	6.5	6.5	100	1000
NNM65038		6.5 x 38mm		19	100	1000
NNM65050		6.5 x 50mm		32	100	1000
NNM65075		6.5 x 75mm		50	100	1000



Nylon Nailin Anchor Round Head

■ Carbon Steel Zinc Yellow Pin

■ Stainless Steel 304 A2 Pin

ZINC INTERNAL 304 SS EXTERNAL



Part No.	Part No.	Description	mm	mm	qty	qty
NNR05025	NNR05025SS	5 x 25mm	5	6.5	100	1000
NNR05040		5 x 40mm		19	100	1000
NNR65025	NNR65025SS	6.5 x 25mm	6.5	6.5	100	1000
NNR65038	NNR65038SS	6.5 x 38mm		19	100	1000
NNR65050		6.5 x 50mm		32	100	1000



ANCHORING



Metal Drive Anchor

□ Body - ZAMAC Alloy, Pin - Carbon Steel Zinc Clear

ZINC INTERNAL



Part No.	Description	mm	mm	qty	qty
MP05022	5 x 22mm	5	6.5	100	500
MP65020	6.5 x 20mm	6.5	6.5	100	500
MP65025	6.5 x 25mm		10	100	500
MP65032	6.5 x 32mm		17	100	500
MP65038	6.5 x 38mm		23	100	500
MP65050	6.5 x 50mm		35	100	500

Not recommended for overhead use



Metal Drive Hammer Screw

□ Body - ZAMAC Alloy, Pin - Carbon Steel Zinc Clear

Threaded square drive screw allows for easy removability if required

ZINC INTERNAL



Part No.	Description	mm	head	mm	qty	qty
MPHS65032	6.5 x 32mm	6.5	sq / no2	17	100	500
MPHS65038	6.5 x 38mm	6.5	sq / no2	23	100	500



Nylon Grey Plug



Part No.	Description	mm	Screw/mm	qty	qty
NGP0525	5 x 25mm	5	3.0 - 3.5	300	3000
NGP0630	6 x 30mm	6	3.5 - 4.0	200	2000
NGP0738	7 x 38mm	7	4.5 - 5.5	100	1000
NGP0840	8 x 40mm	8	5.0 - 6.0	100	1000
NGP1050	10 x 50mm	10	6.0 - 7.5	50	500
NGP1260	12 x 60mm	12	7.5 - 8.0	25	250

Refer page 2 (inside cover) for screw gauge conversion chart

Follow Us

Facebook
ICCONS Pty Ltd

Instagram
iccons.pty.ltd

LinkedIn
ICCONS Pty Ltd



ANCHORING

FRULSIDER
YOUR FIXING FACTORY

3DG COATING

COATING THICKNESS

High resistance zinc coating with reduced thickness, that does not interfere with the thread geometry, guaranteeing the correct body/nut coupling.

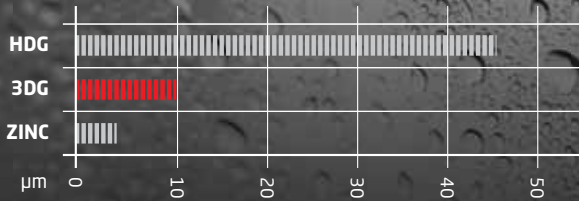

MAX CORROSION RESISTANCE

Corrosion resistance in Salt Spray up to 1000 hours (min. resistance depending on the geometry of the fixing).

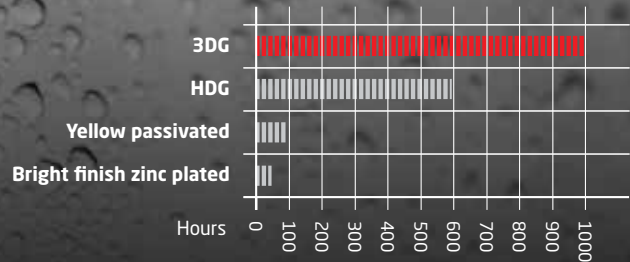

For products with 3DG coating look for the **3DG COATING** logo, for full details see page 24



FRULSIDER YOUR FIXING FACTORY **TPP** Hammer Screw

Carbon Steel Zinc Clear - Removable Screw

Stainless Steel 304 A2 - Removable Screw



ZINC INTERNAL		304 SS EXTERNAL								
Part No.	Part No.	Description	mm	mm	mm	Drive	Pin / mm	qty	qty	
FTPP05030 (62700b05030)		5 x 30mm	5	25	5	Pozi	3.4	300	3000	
FTPP05050 (62700b05050)		5 x 50mm			25	Pozi		200	2000	
FTPP06035 (62700b06035)		6 x 35mm	6	30	5	Pozi	3.8	200	2000	
	FTPP06040SS (62701x06040)	6 x 40mm			10	Pozi		200	2000	
FTPP06050 (62700b06050)	FTPP06050SS (62701x06050)	6 x 50mm			20	Pozi		100	1000	
FTPP06060 (62700b06060)		6 x 60mm			30	Pozi		100	1000	
FTPP08040 (62700b08040)		8 x 40mm	8	35	5	Pozi	4.8	200	2000	
FTPP08060 (62700b08060)		8 x 60mm			20	Pozi		150	1500	
FTPP08080 (62700b08080)	FTPP08080SS (62701x08080)	8 x 80mm			40	Pozi		150	1500	
FTPP08100 (62700b08100)		8 x 100mm			60	Pozi		100	1000	
FTPP08120 (62700b08120)		8 x 120mm			80	Pozi		100	1000	



ANCHORING



FRULSIDER FM-XP® Universal Nylon Plug

YOUR FIXING FACTORY



Part No.	Description	mm	mm	Screw/mm	qty	qty
FMXP06033 (65000006033)	6 x 33mm	6	33	4.5	200	2000
FMXP08052 (65000008052)	8 x 52mm	8	52	5	100	1000
FMXP10065 (65000010065)	10 x 65mm	10	65	6	50	500

Refer page 2 (inside cover) for screw gauge conversion chart



FRULSIDER TU Nylon Plug

YOUR FIXING FACTORY



Part No.	Description	mm	mm	Screw/mm	qty	qty
FTU05025 (60101005025)	5 x 25mm	5	25	2.6 - 4	100	1000
FTU06030 (60101006030)	6 x 30mm	6	30	4.5	100	1000
FTU07035 (60101007035)	7 x 35mm	7	35	4.5 - 5	150	1500
FTU08040 (60101008040)	8 x 40mm	8	40	5	100	1000
FTU10050 (60101010050)	10 x 50mm	10	50	6 - 8	50	500
FTU12060 (60101012060)	12 x 60mm	12	60	8 - 10	25	250
FTU14080 (60101014080)	14 x 80mm	14	80	10 - 12	20	200
FTU16080 (60101016080)	16 x 80mm	16	80	12 - 14	15	150

Refer page 2 (inside cover) for screw gauge conversion chart



FRULSIDER TUP Nylon Through Anchor

YOUR FIXING FACTORY



Part No.	Description	mm	mm	mm	Screw/mm	qty	qty
FTUP06060 (60300006060)	6 x 60mm	6	30	30	4	100	1000
FTUP08060 (60300008060)	8 x 60mm	8	40	20	5.5	100	1000

Refer page 2 (inside cover) for screw gauge conversion chart



FRULSIDER TUP3 Nylon Through Anchor

YOUR FIXING FACTORY



Part No.	Description	mm	mm	Screw/mm	qty	qty
FTUP308080 (64200008080)	8 x 80mm	8	80	5.5 - 6	100	1000
FTUP310100 (64200010100)	10 x 100mm	10	100	7	100	1000

Refer page 2 (inside cover) for screw gauge conversion chart



ANCHORING

X1EVO

X1EVO-L

NEW

ALL BASE MATERIALS



ALL SCREW TYPES



100% functioning with all screws, even metric threaded screws.

GREATER ANCHORING DEPTH



ALL BASE MATERIALS



ALL SCREW TYPES



Solid Base Material



Hollow Base Material



Plasterboard Base Material



FRULSIDER X1 EVO & X1 EVO-L

YOUR FIXING FACTORY



Part No.	Description	mm		Screw/mm		qty	
		mm	mm	metric	metric	qty	qty
FMX1P05025 (60070005025)	5 x 25mm Plug only - X1 EVO	5	25	3.5 - 4	n/a	100	3200
FMX1P06030 (60070006030)	6 x 30mm Plug only - X1 EVO	6	30	4.5	M4	100	3200
FMX1P06050 (60070006050)	6 x 50mm Plug only - X1 EVO-L NEW	6	50	4.5	M4	200	600
FMX1P08040 (60070008040)	8 x 40mm Plug only - X1 EVO	8	40	5 - 6	M5	100	1600
FMX1P08060 (60070008060)	8 x 60mm Plug only - X1 EVO-L NEW	8	60	5 - 6	M5	100	800
FMX1P10050 (60070010050)	10 x 50mm Plug only - X1 EVO	10	50	6	M6	50	800
FMX1P10070 (60070010070)	10 x 70mm Plug only - X1 EVO-L NEW	10	70	6	M6	50	400
FMX1P12060 (60070012060)	12 x 60mm Plug only - X1 EVO	12	60	8	M8	25	400
FMX1P14070 (60070014070)	14 x 70mm Plug only - X1 EVO	14	70	10	M10	20	320

Refer page 2 (inside cover) for screw gauge conversion chart



ANCHORING



FRULSIDER X1 evo w/ Countersunk Screw

☐ Carbon Steel Zinc Clear Countersunk Screw



Part No.	Description	mm	mm	Screw/mm	mm	Drive	qty	qty
FX1PC05025 (60071b05025)	5 x 25mm with Countersunk Screw	5	25	3.5 - 4	30	Pozi 2	100	3200
FX1PC06030 (60071b06030)	6 x 30mm with Countersunk Screw	6	30	4.5	40	Pozi 2	100	1600
FX1PC06030B (60071b06030)	6 x 30mm with Countersunk Screw Bulk Bucket (200pce)	6	30	4.5	40	Pozi 2	1	1
FX1PC08040 (60071b08040)	8 x 40mm with Countersunk Screw	8	40	5 - 6	50	Pozi 2	50	800
FX1PC08040B (60071b08040)	8 x 40mm with Countersunk Screw Bulk Bucket (100pce)	8	40	5 - 6	50	Pozi 2	1	1
FX1PC10050 (60071b10050)	10 x 50mm with Countersunk Screw	10	50	6	60	Pozi 3	25	400

Refer page 2 (inside cover) for screw gauge conversion chart



FRULSIDER X1 evo w/ Hex Head Screw

☐ Carbon Steel Zinc Clear Hex Head Screw



Part No.	Description	mm	mm	Screw/mm	mm	Drive(mm)	qty	qty
FX1PH08040 (60073b08040)	8 x 40mm with Hex Head Screw	8	40	5 - 6	50	10	100	600
FX1PH10050 (60073b10050)	10 x 50mm with Hex Head Screw	10	50	6	60	10	100	400
FX1PH12060 (60073b12060)	12 x 60mm with Hex Head Screw	12	60	8	70	13	50	200
FX1PH14070 (60073b14070)	14 x 70mm with Hex Head Screw	14	70	10	80	17	25	150

Refer page 2 (inside cover) for screw gauge conversion chart



FRULSIDER X1 evo w/ Pan Head Screw

☐ Carbon Steel Zinc Clear Pan Head Screw

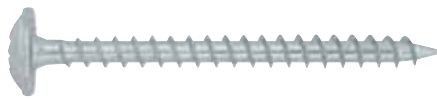

Part No.	Description	mm	mm	Screw/mm	mm	drive	qty	qty
FX1PP05025 (60072b05025)	5 x 25mm with Wide Pan Head Screw	5	25	3.5 - 4	30	Pozi 2	100	1600
FX1PP06030 (60072b06030)	6 x 30mm with Wide Pan Head Screw	6	30	4.5	40	Pozi 2	100	1200
FX1PP08040 (60072b08040)	8 x 40mm with Wide Pan Head Screw	8	40	5 - 6	50	Pozi 3	50	600

Refer page 2 (inside cover) for screw gauge conversion chart

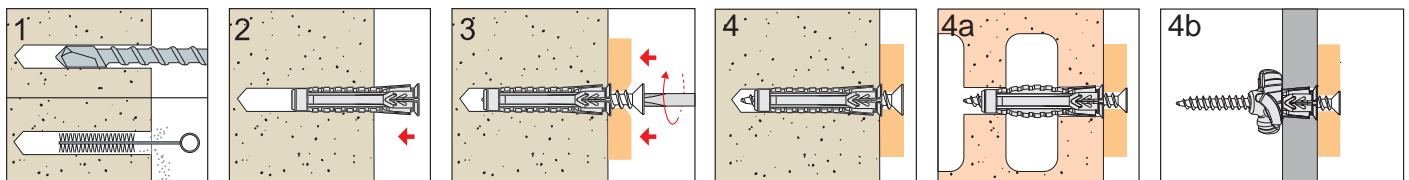



FRIULSIDER
YOUR FIXING FACTORY

FMX5

MULTI-EXPANSION LONG PLUG



ULTRA FLEXIBLE
High quality nylon



GREATER GRIP
*Innovative variable geometry
multi-expansion*



**SCREW ALWAYS
PRE-ASSEMBLED**

Ready to use.

Available in versions:

- *White zinc plated,*
- *3DG coating*
- *Stainless steel A4 70*



- **NO WINGS:** *easy to install, adjust & even remove*
- **LOW TORQUE:** *can be blocked by hand*
- **Pre-assembled:** *ready to use, hammer in position*

Distributors : FMX5 display board available upon request



ANCHORING



FRULSIDER
YOUR FIXING FACTORY

FM-X5 Nylon Frame Fixing

Carbon Steel Zinc Clear Hex Head Screw

Carbon Steel Galvanised Hex Head Screw

3DG
COATING



ZINC INTERNAL GAL EXTERNAL



Part No.	Part No.	Description	mm	mm	mm	mm	mm	qty	qty
FHMX510085 (64302b10085)	FHMX510085G (64302c10085)	10 x 85mm	10	70	15	Hex with internal T40	7 x 90	50	1000
FHMX510100 (64302b10100)	FHMX510100G (64302c10100)	10 x 100mm			30	Hex with internal T40	7 x 105	50	500
FHMX510115 (64302b10115)	FHMX510115G (64302c10115)	10 x 115mm			45	Hex with internal T40	7 x 120	50	500
FHMX510135 (64302b10135)	FHMX510135G (64302c10135)	10 x 135mm			65	Hex with internal T40	7 x 140	50	500
FHMX510160 (64302b10160)	FHMX510160G (64302c10160)	10 x 160mm			90	Hex with internal T40	7 x 165	50	500

NOTE: Fire Rating (F90), valid for facade applications only.



FRULSIDER
YOUR FIXING FACTORY

FM-X5 Nylon Frame Fixing

Carbon Steel Zinc Clear Countersunk Screw

Stainless Steel 316 A4 Countersunk Screw



Now fire rated for metal door frames

ZINC INTERNAL 316 SS EXTERNAL



Part No.	Part No.	Description	mm	mm	mm	Torx	mm	qty	qty
FCMX510085 (64301b10085)	FCMX510085SS (64301010085)	10 x 85mm	10	70	15	T40 CSK	7 x 90	50	1000
FCMX510100 (64301b10100)	FCMX510100SS (64301010100)	10 x 100mm			30	T40 CSK	7 x 105	50	500
FCMX510115 (64301b10115)	FCMX510115SS (64301010115)	10 x 115mm			45	T40 CSK	7 x 120	50	500
FCMX510135 (64301b10135)	FCMX510135SS (64301010135)	10 x 135mm			65	T40 CSK	7 x 140	50	500
FCMX510160 (64301b10160)	FCMX510160SS (64301010160)	10 x 160mm			90	T40 CSK	7 x 165	50	500

NOTE: Fire Rating (F90), valid for facade applications & metal door frames



ANCHORING



FRULSIDER **FM-X5s** Reduced Embedment Nylon Frame Fixing

YOUR FIXING FACTORY

Carbon Steel Zinc Clear Hex Head Screw

Carbon Steel Galvanised Hex Head Screw w/ flanged Plug

Carbon Steel Galvanised Hex Head Screw non flanged Plug

3DG
COATING

3DG
COATING



Part No.	Part No.	Part No.	Description	mm	mm	mm	head	mm	qty	qty
FMX5SH10060 (64404b10060)	FMX5STH10060G (64404c10060)	FMX5SHNF10060G	10 x 60	10	55	10	Hex with internal T40	7 x 65	50	500

FMX5 SAFER

- FM-X5 MULTI-EXPANSION PLUG
- SPECIAL ANTI-ROTATION SCREW HEAD
- TAMPER-PROOF ZAMAK Insert
- TORX T40 RECESS
- AVAILABLE ZINC CLEAR & 316SS



FRULSIDER **FM-X5 SAFER** Anti-Intrusion System

YOUR FIXING FACTORY

Carbon Steel Zinc Clear Tamper Proof Head Screw

Stainless Steel 316 A4 Tamper Proof Head Screw

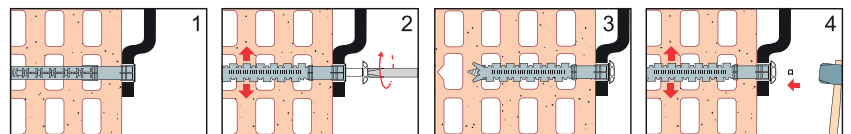
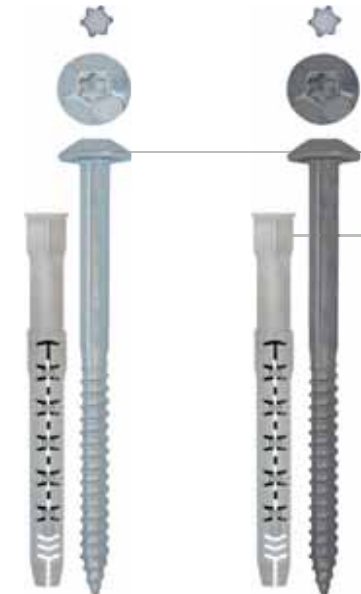

Part No.	Part No.	Description	mm	mm	mm	Torx	mm	qty	qty
FMX5SAF10085 (64301b10085)	FMX5SAF10085SS (64301010085)	10 x 85mm	10	70	15	T40 CSK	7 x 90	50	1000



FMX5 TOP

TOP PERFORMANCES COMPARABLE TO METAL ANCHORS



TOP SCREW PREASSEMBLED

Asymmetrical thread and thicker diameter.



PULL-OUT VALUES DOUBLE

than FM-X5 in concrete

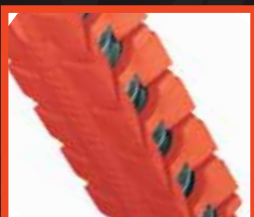

TOP PLUG

Nylon PA 6.6 ultra resistant

**3DG
COATING**

FRÜLSIDER FM-X5 TOP

YOUR FIXING FACTORY

Nylon Frame Fixing

Carbon Steel Zinc Clear Hex Head Screw w/ flanged Plug

Carbon Steel Galvanised Hex Head Screw w/ flanged Plug

Stainless Steel 316 A4 Hex Head Screw w/ flanged Plug

**3DG
COATING**

ZINC

INTERNAL
Class 8.8

GAL

EXTERNAL
Class 8.8316
SSEXTERNAL
316 A4-70

Part No.	Part No.	Part No.	Description	mm	mm	mm	head	mm	qty	qty
FMX5TH10085 (64405b10085)	FMX5TH10085G (64405c10085)	FMX5TH10085SS (64405010085)	10 x 85mm	10	70	15	Hex with internal T40	7 x 90	50	1000
FMX5TH10100 (64405b10100)	FMX5TH10100G (64405c10100)	FMX5TH10100SS (64405010100)	10 x 100mm			30	Hex with internal T40	7 x 90	50	500
FMX5TH10115 (64405b10115)	FMX5TH10115G (64405c10115)	FMX5TH10115SS (64405010115)	10 x 115mm			45	Hex with internal T40	7 x 90	50	500
FMX5TH10135 (64405b10135)	FMX5TH10135G (64405c10135)	FMX5TH10135SS (64405010135)	10 x 135mm			65	Hex with internal T40	7 x 90	50	500
FMX5TH10160 (64405b10160)	FMX5TH10160G (64405c10160)	FMX5TH10160SS (64405010160)	10 x 160mm			90	Hex with internal T40	7 x 90	50	500



ANCHORING



FRULSIDER **FM-ISO MAX** Insulation Nail

☐ Fixing with steel nail for ETICS thermal insulation system
Concrete, solid brick, honeycomb brick, cell like clay brick, lightweight honeycomb brick, hollow dense aggregate block, hollow light aggregate block, aerated concrete and solid stone.



Not suitable for fire rated applications

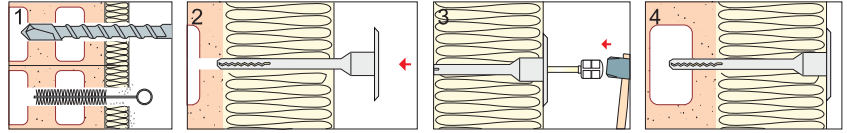

Part No.	Description	mm	Min. Embed Depth	mm	mm	mm	qty
FM-ISOMAX08100 (6192500810000)	8 x 100mm	8	55	25 - 45	60	200	
FM-ISOMAX08120 (6192500812000)	8 x 120mm		55	45 - 65	60	200	
FM-ISOMAX08140 (6192500812000)	8 x 140mm		55	65 - 85	60	200	

Please refer to insulation manufacturer instructions for fastener suitability. Other lengths available on request.

NEW



TOGE **TID METAL** Insulation Nail

■ Galvanised insulation panel fixing
Concrete, solid brick, aerated concrete and solid stone.

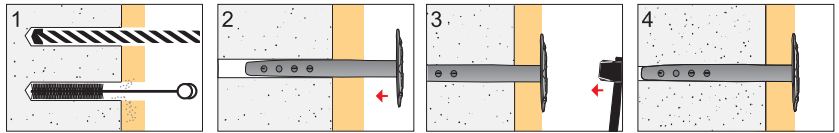

Part No.	Description	mm	mm	Min. Embed Depth	mm	mm	qty
TIDSMETAL08080 (031 061 080)	8 x 80mm	8	20-40	40	35	250	
TIDSMETAL08110 (031 061 110)	8 x 110mm		50 - 70	40	35	250	
TIDSMETAL08140 (031 061 140)	8 x 140mm		75-100	40	35	250	

Please refer to insulation manufacturer instructions for fastener suitability.

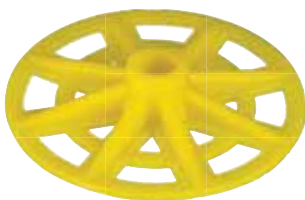

Nylon Insulation Washer

For securing insulation board
Use with Class 3 bugle head or chipboard screws

Part No.	Description	qty	qty
PWY40	40mm OD, suits bugle head and chipboard screws	100	1000



FOX

SELFDRILLING PLUG FOR FIXING TO FOAM INSULATION CLADDING



FRIULSIDER FOX Torx T40 Recess - Ø25

YOUR FIXING FACTORY

Suitable for fixing:

- Lighting
- Signs
- Electrical applications
- Mechanical applications



Min. insertion of screw	Gauge	qty
mm		

Part No.	Description	Min. insertion of screw mm	Gauge	qty
FOXIPT25050 (61951025050)	25 x 50mm	30	10g	50
FOXIPT25085 (61951025085)	25 x 85mm	40	10g	25

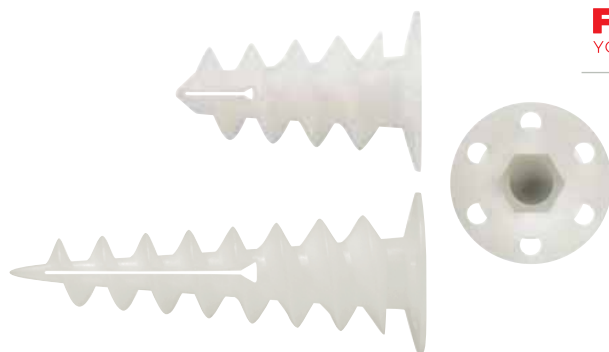

FRIULSIDER FOX 12mm Hex Recess - Ø33

YOUR FIXING FACTORY

Suitable for fixing:

- Drain pipe collars
- Heating/cooling applications
- Lighting
- Signs
- Electrical applications
- Mechanical applications



Min. insertion of screw	Metric	Wood / mm	qty
mm			

Part No.	Description	Min. insertion of screw mm	Metric	Wood / mm	qty
FOXIPH33050 (61951033050)	33 x 50mm	50	M8	8	50
FOXIPH33085 (61951033085)	33 x 85mm	50	M8	8	25

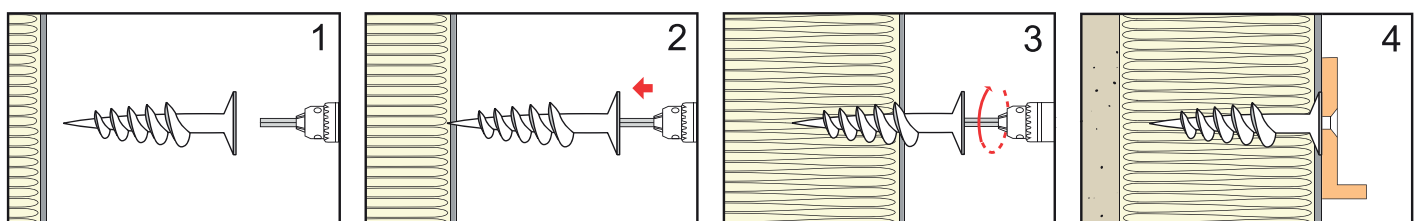



ANCHORING



50 meter

50 meter

5 meter

Plastic Spaghetti Roll 5.0mm & 5.5mm

Part No.	Part No.	Description	Plug Colour	mm	mm	qty	qty
PSG550		5.0mm x 50m		5.5	3.0 - 3.5	1	10
	PSR5550	5.5mm x 50m		6	3.5 - 4.0	1	10
	PSR5505S	5.5mm x 5m		6	3.5 - 4.0	1	50

Refer page 205 for screw gauge conversion chart

PVC Wall Plug 6mm



Part No.	Description	Plug Colour	mm	mm	qty	No. Of Frames
PVCR25	6 x 25mm		6	8g /4mm	1000	25 plugs x 40 frames
PVCR30	6 x 30mm			8g /4mm	1000	25 plugs x 40 frames
PVCR38	6 x 38mm			8g /4mm	1000	25 plugs x 40 frames
PVCR50	6 x 50mm			8g /4mm	1000	25 plugs x 40 frames

PVC Wall Plug 7mm



Part No.	Description	Plug Colour	mm	mm	qty	No. Of Frames
PVCG25	7 x 25mm		7	10g - 12g / 5 - 5.5mm	1000	25 plugs x 40 frames
PVCG30	7 x 30mm			10g - 12g / 5 - 5.5mm	1000	25 plugs x 40 frames
PVCG38	7 x 38mm			10g - 12g / 5 - 5.5mm	500	25 plugs x 20 frames
PVCG50	7 x 50mm			10g - 12g / 5 - 5.5mm	500	25 plugs x 20 frames

PVC Wall Plug 8mm



Part No.	Description	Plug Colour	mm	mm	qty	No. Of Frames
PVCB25	8 x 25mm		8	14g / 6 - 7mm	1000	25 plugs x 40 frames
PVCB38	8 x 38mm			14g / 6 - 7mm	500	25 plugs x 20 frames
PVCB50	8 x 50mm			14g / 6 - 7mm	500	25 plugs x 20 frames



Toggle Strap Hollow Wall Anchor

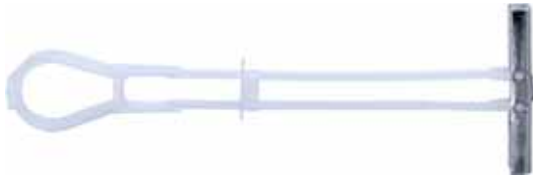

Problem solving long reach hollow wall anchor



Part No.	Description	mm	metric	mm	qty	qty
PTSM06	M6 Hollow Wall Anchor	13	M6	Up to 64mm	50	300



Spring Toggles

Round Head - Zinc Clear

Cup Hook - Zinc Clear

ZINC INTERNAL

ZINC INTERNAL



Part No.	Part No.	Description	mm	mm	qty	qty
STR18-2		1/8" X 50mm	10	30	50	150
STR18-3		1/8" X 75mm		50	100	300
STR316-2		3/16" X 50mm	13	25	50	150
STR316-3		3/16" X 75mm		48	50	150
	STRCH316-3	3/16" x 75mm		50	50	150
STR316-4		3/16" X 100mm		74	50	150

Toggle Plug

Duo-Function

Light duty duo-function nylon anchor for use in solid masonry or to function as a toggle anchor in hollow materials

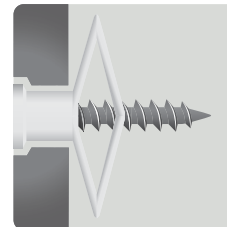
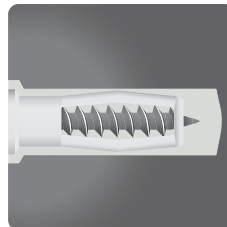

Part No.	Description	mm	mm	mm	qty	qty
PTP10	10mm Plastic Toggle Plug	8	10 - 13	3.5 (6g) - 4.2 (8g)	100	1000
PTP13	13mm Plastic Toggle Plug	8	13 - 16	3.5 (6g) - 4.2 (8g)	100	1000
PTP16	16mm Plastic Toggle Plug	8	16 - 20	3.5 (6g) - 4.2 (8g)	100	1000



ONE SCREW...



Available in
32 & 50mm
PH2 Phillips or
SQ2 Square drives

Suitable in most fast materials:

- Concrete
- Masonry
- Block
- Timber
- Plasterboard
- etc...

If removed Dog-Bite leaves a smaller hole than other systems

Designed for smooth entry, clean cutting and powerful holding strength

Heat treated material penetrates thin metal & wood studs

Each Blister & Box comes with a **BONUS** Driver Bit

NEW

Dog-Bites™

Zinc Clear

Carbon Steel Mechanically Galvanised



ZINC

INTERNAL

GAL

EXTERNAL



	Part No.	Part No.	Description	mm	Drive Type	mm	qty	qty
Phillips	DBPH32-100	DBPH32G-100	32mm Pan head - No.2 Phillips Drive	5	No2 PH	20	100	2500
	DBPH32-500	DBPH32G-500	32mm Pan head - No.2 Phillips Drive	5	No2 PH	20	500	5000
Square	DBSQ32-100	DBSQ32G-100	32mm Pan head - No.2 Square Drive	5	No2 Sq	20	100	2500
	DBSQ50 -100	DBSQ50G-100	50mm Pan head - No.2 Square Drive	5	No2 Sq	20	100	2000



ANCHORING

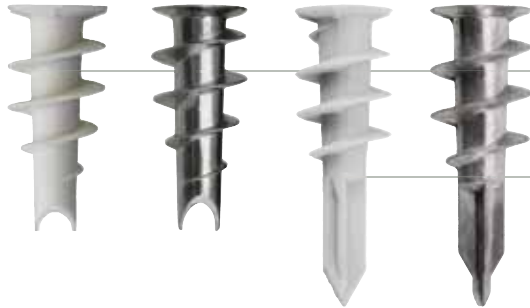

Plaster-Bites®

Fish Mouth - Metal or Nylon Plaster-Bites®

Drill Point Metal or Nylon Plaster-Bites®

Part No.	Part No.	Part No.	Part No.	Description	mm	qty	qty
PBNYLON	PBMETAL	PBNYLONDP	PBMETALDP	Self drilling wall anchor for plasterboard	3.5 (6g) - 4.2 (8g)	100	1000

Plaster-Bites® With Screw

Drill Point Nylon Plaster-Bites®



Part No.	Description		mm	qty	qty
PBNYLONDP-WS	Self drilling wall anchor for plasterboard with Pan head screw	Ph2	3.5 (6g) - 4.2 (8g)	100	1000

Suitable for variety of base materials such as:

- Plasterboard
- Hollow Blocks
- Solid Blocks
- Concrete
- Masonry
- Tile clad FC sheet

Grip Nut

Multi-purpose problem solving EPDM Rivet style fixing
Perfect for use in tiles /sanitary fittings etc
Acoustical fixing (sound dampening)

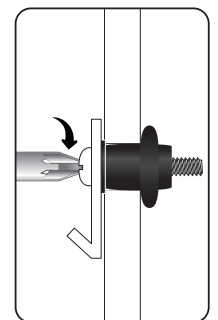
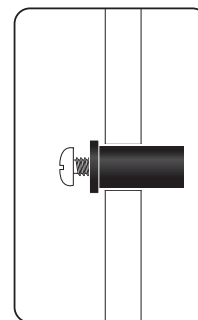
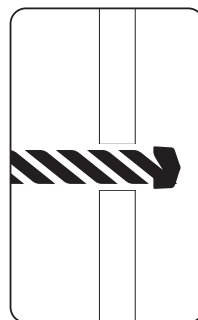

Part No.	Part No.	Description	mm	mm	qty	qty
GNM410		M4 x 10mm	8	4	200	5000
GNM515		M5 x 15mm	10	5	200	5000
GNM525		M5 x 25mm		16	100	1600
GNM540	GNM540WS	M5 x 40mm		30	50	800

*M4 & M5 machine threaded Pan Head (Phillips #2) screws available on request.



ANCHORING



ZINC INTERNAL

ZINC INTERNAL

Hollow Wall Anchor

Zinc Clear for use with setting tool HA-STHD.

Zinc Clear Drive in.

Part No.	Part No.	Description	mm	mm	qty	qty
HA4XS		8mm x 20mm (with M4 screw)	8	0-5	100	500
HA4S	HA4SD	8mm x 32mm (with M4 screw)		5 - 10	100	500
HA4SL		8mm x 46mm (with M4 screw)		10 - 18	100	1000
HA4L		8mm x 46mm (with M4 screw)		18 - 24	100	500
HA6S		10mm x 52mm (with M6 screw)	10	10 - 21	50	250
HA8S		11mm x 52mm (with M8 screw)	11	10 - 21	50	250



Hollow Wall Anchor Setting Tool

The Original Optee

- Controlled anchor expansion
- No crushing of the wall
- Optimal applicator fit



Part No.	Description	qty	qty
HA-STHD	Heavy Duty Setting Tool	1	20

FEATURES

1. Material - Brushed aluminium.
2. Ergonomic handle - Allows quick and easy installation, smooth and effortless.
3. Adjustable expansion - suitable for all anchor lengths.
4. Soft Touch Pad - Doesn't damage the wall during use.
5. Handle lock function - For safe and easy storage.
6. Suitable for the expansion of all hollow wall anchors 1/8" to 3/16".



Optee

The Only one in Australia!

Scell-it®





Packing Shims - Boxes & Tubs

For Packing around Windows & Doors

Part No.	Part No.	Description	Colour	qty	qty
PKS01575		1.5mm x 75mm White Packer - BOX		100	2400
	PKS01575-TUB	1.5mm x 75mm White Packer - TUB		800	3200
PKS03275		3.2mm x 75mm Blue Packer - BOX		100	1200
	PKS03275-TUB	3.2mm x 75mm Blue Packer - TUB		500	2000
PKS05075		5.0mm x 75mm Red Packer - BOX		100	800
	PKS05075-TUB	5.0mm x 75mm Red Packer - TUB		400	1600
PKS06475		6.4mm x 75mm Green Packer - BOX		100	800
	PKS06475-TUB	6.4mm x 75mm Green Packer - TUB		300	1200
PKS10075		10.0mm x 75mm Black Packer - BOX		100	600
	PKS10075-TUB	10.0mm x 75mm Black Packer - TUB		200	800



Packing Shims - Mixed Tub

For Packing around Windows & Doors

Part No.	Description		Colour	qty	qty
PKSMIX-TUB	1.5mm x 75mm White Packer	150 x White Packing Shims per tub		1 Tub (400pce)	4 x Tubs (1600pce)
	3.2mm x 75mm Blue Packer	90 x Blue Packing Shims per tub			
	5.0mm x 75mm Red Packer	90 x Red Packing Shims per tub			
	6.4mm x 75mm Green Packer	20 x Green Packing Shims per tub			
	10.0mm x 75mm Black Packer	50 x Black Packing Shims per tub			



**EVERY
TOOL IBOX
NEEDS A
WINBAG!**

Winbag Inflatable Packing Device

- Save Time
- No More Shims
- Max Load 100KGS / winbag
- For joints 2mm to 50mm
- Can be used again and again
- Leaves joint empty ready for sealing
- Easy & Effective
- Adjusting and positioning heavy doors
- Window frames installation
- Levelling appliances
- Soft air cushion doesn't leave scratches or marks & protects the frame

Part No.	Description	Joint Width	Load Capacity	qty
PKSWNBAG	WINBAG - Inflatable and Adjustable Packing Device	mm 2 - 50mm	kg 100 kg	1



ANCHORING



Knurled Shank Masonry Nail

Zinc Clear

ZINC



Part No.	Description	mm	mm	qty	qty
KMN25	3.7 x 25mm	25	3.7	100	2000
KMN40	3.7 x 40mm	40	3.7	100	1000
KMN50	3.7 x 50mm	50	3.7	100	1000
KMN65	3.7 x 65mm	65	3.7	100	1000
KMN75	3.7 x 75mm	75	3.7	100	1000

* Also referenced on Page 98



Mickey Pins

Zinc Clear

ZINC



Part No.	Description	mm	mm	qty	qty
MPW20	Washed Mickey Pin hand drive nail - 20 x 2.5mm	20	2.5	500	5000
MPW25	Washed Mickey Pin hand drive nail - 25 x 2.5mm	25	2.5	500	5000
MPW30	Washed Mickey Pin hand drive nail - 30 x 2.5mm	30	2.5	500	5000
MPW40	Washed Mickey Pin hand drive nail - 40 x 2.5mm	40	2.5	500	4000
MPW50	Washed Mickey Pin hand drive nail - 50 x 2.5mm	50	2.5	500	4000

* Also referenced on Page 99

Download the ICCONS® App today!

Features:

- Adhesive Volume Calculator
- What's New
- View Our Catalogue
- Find A Distributor
- NCC F.A.Q. Sheet & NCC Products
- Contact us

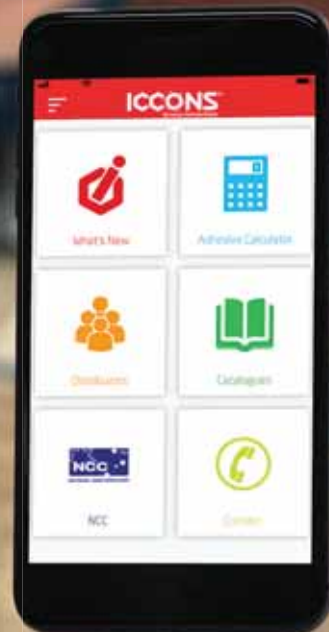

Available on the
App Store



GET IT ON
Google Play



ANCHORING

ICCONS®

BLDC
MOTOR

LITHIUM
Long Life **-ION**

KEYANG

NEW

1,000 Nm



Powerful

Max. tightening torque of 1,000 Nm.

Safety

Soft start function prevents wrist injuries.

BLDC Motor

High output and durability compared to conventional brushed motor.

IW18BL-H-NT SKIN

More information on page 219



It's a brand new way to do the BIS, Chemselect

- Clear, easy to understand labelling
- Colour coded for specific performance - Red, Platinum, Green, Blue & Gold
- Highest International Approvals National Code Compliance
- Cracked Concrete and Seismic Approved
- Marine & Flooded Hole Approved



How Much Adhesive Do You Need? Work It Out On The ICCONS® App!



Pure-Epoxy	Hybrid	Vinylester	Polyester	VD-Quartz
Page 67	Page 69	Page 71	Page 73	Page 75



ADHESIVES

ICCONS®

CHEMSELECT CHEMSELECT CHEMSELECT CHEMSELECT CHEMSELECT CHEMSELECT



SELECTION GUIDE



BIS-PE
Pure Epoxy
CODE RED



BIS-HY
Hybrid
CODE PLATINUM



BIS-V
Vinylester
CODE GREEN



BIS-P
Polyester
CODE BLUE



VDP-Q
Capsules
CODE GOLD

	Load Performance	EXTREME	EXTREME	HIGH	MEDIUM	EXTREME
	Working Time*	30 mins	3 mins	6 mins	6 mins	N/A
	Curing Time*	10 hours	30 mins	45 mins	45 mins	20 mins
	Overhead					
	Masonry/Brickwork					
	Rebar					
	Threaded Studs					
	Threaded Inserts					
	Wet Holes					
	Water Filled Holes					
	Core Drilled Holes					
	ETA Approval					
	Cracked Concrete					
	Earthquake Seismic Approval	C1 & C2	C1 & C2	C1		
	Fire Rated					
	Green Projects - Low VOC					
	National Code Compliant					

* Based on 20°C dry concrete

Note: The above information should be used as a general guide only. Products should always be approved before use by a design professional responsible for the application.



ADHESIVES

CHEMSELECT CHEMSELECT CHEMSELECT CHEMSELECT CHEMSELECT CHEMSELECT

CODE RED

B+BTEC BIS-PE Injection



Pure Epoxy - EXTREME STRENGTH

Coming Soon
More features &
Higher performance



When it's RED it's Pure Epoxy.



ICCONS® BIS-PE is the superior 3:1 High Performance Pure Epoxy.

BIS-PE is the ultimate choice for Threaded rod & Rebar in Cracked or Non-Cracked Concrete.

Approved for use in Diamond Core Drilled Holes and C1/C2 Seismic Applications.

- Main Roads (QLD TMR) Approved
- Potable water approval

Concrete Temperature	Processing time	Curing Time	
		Dry Holes	Wet Holes
+5°C	2 h	50 h	100 h
+10°C	1.5 h	30 h	60 h
+20°C	30 min	10 h	20 h
+30°C	20 min	6 h	12 h
+40°C	12 min	4 h	8 h



**How Much Adhesive
Do You Need?
Work It Out On The
ICCONS® App!**



Part No.	Description	qty	qty
BIS-PE385	385ml injection cartridge includes 2 x mixer nozzles	2	12
BIS-PE585	585ml injection cartridge includes 2 x mixer nozzles	2	12
BIS-PE1400	1400ml injection cartridge includes 2 x mixer nozzles (pneumatic tool required for 1400ml system) NEW	2	
CNOZ10-PE	Mixer Nozzle for BIS-PE Epoxy (includes extension nozzle) (Pack of 10)	10	n/a

For compatible dispensing tools see page 77



Load Performance
EXTREME



Working Time
30 mins



Curing Time
10 hours



Wet Holes



Water Filled Holes



Core Drilled Holes



Overhead



Masonry /
Brickwork



Rebar



Threaded Studs



Fire Rated



ETA
Approval



ETA
Cracked Concrete



C1 & C2
Seismic Approval



Green Projects -
LOW VOC



National Code
Compliant



CODE PLATINUM

B+BTEC BIS-HY Injection



Hybrid - EXTREME STRENGTH



Coming Soon
More features & Higher performance



When it's PLATINUM it's Hybrid

Combining the superior strength of Epoxy with a fast cure Vinylester.

Fire Rating F120 (2 hours) and approved for use in temperatures up to 160°C.

ICCONS® BIS-HY is a rapid cure, styrene free, non-sag, extreme performance Hybrid Injection Adhesive.

BIS-HY is suitable for Threaded Rod and Rebar in cracked and non-cracked concrete and Australia's first rapid cure with Seismic C2 approval for threaded rod.

- Main Roads (QLD TMR) Approved
- Potable water approval



Concrete Temperature	Processing time	Curing Time	
		Dry Holes	Wet Holes
-5°C to -1°C	50 min	5 h	10 h
0°C to +4°C	25 min	3.5 h	7 h
+5°C to +9°C	15 min	2 h	4 h
+10°C to +14°C	10 min	1 h	2 h
+15°C to +19°C	6 min	40 min	1 h
+20°C to +29°C	3 min	30 min	1 h
+30°C to +40°C	2 min	30 min	1 h

Part No.	Description	qty	qty
BIS-HY420	420ml Injection Cartridge includes 2 x mixer nozzles	1	12
BIS-HY280	280ml Injection Cartridge includes 2 x mixer nozzles	1	10
CNOZ10-HY	Mixer Nozzle for BIS-HY Hybrid (Pack of 10)	10 pack	n/a

For compatible dispensing tools see page 77

Load Performance
EXTREME

Working Time
3 mins

Curing Time
30 mins

Wet Holes

Water Filled Holes

Overhead

Masonry /
Brickwork

Rebar

Threaded Studs

Threaded Inserts

Fire Rated

ETA Approval

ETA Cracked Concrete

C1 & C2 Seismic Approval

Green Projects - LOW VOC

National Code Compliant



ADHESIVES

CHEMSELECT CHEMSELECT CHEMSELECT CHEMSELECT CHEMSELECT CHEMSELECT

CODE GREEN

B+BTEC BIS-V Injection



Vinylester - EXTREME STRENGTH



When it's GREEN it's Vinylester.



ICCONS® BIS-V is a Rapid Cure, Styrene Free, Non Sag, High Performance Injection Adhesive.

BIS-V is suitable for Threaded rod and Rebar in Cracked and Non-Cracked concrete as well as C1 Seismic applications.

Approved for use in Diamond Core Drilled Holes and C1/C2 Seismic Applications.

- Main Roads (QLD TMR) Approved
- Potable water approval

Concrete Temperature	Processing time	Curing Time	
		Dry Holes	Wet Holes
-10°C	90 min	24 h	48 h
-5°C	90 min	14 h	28 h
0°C	45 min	7 h	14 h
+5°C	25 min	2 h	4 h
+10°C	15 min	80 min	160 min
+20°C	6 min	45 min	90 min
+30°C	4 min	25 min	50 min
+35°C	2 min	20 min	40 min
+40°C	1.5 min	15 min	30 min



How Much Adhesive Do You Need? Work It Out On The ICCONS® App!

Available on the App Store | GET IT ON Google Play

BIS-V420KIT



Part No.	Description	qty	qty
BIS-V420	420ml Injection Cartridge includes 2 x mixer nozzles	1	12
BIS-V300	300ml Injection Cartridge includes 2 x mixer nozzles	1	10
BIS-V420KIT	Installation kit consists of 1 x Dispensing Gun, 3 x 420ml BIS-V420, 1 x Blow Pump, 6 x Nozzles, 4 x Metal Brushes, 5 x Plastic Sleeves for M10 & M12	1	
CNOZ10-V	Mixer Nozzle for BIS-V Vinylester & BIS-P Polyester (Pack of 10)	10 pack	n/a

For compatible dispensing tools see page 77



Load Performance HIGH



Working Time 6 mins



Curing Time 45 mins



Wet Holes



Water Filled Holes



Overhead



Masonry / Brickwork



Rebar



Threaded Studs



Fire Rated



ETA Approval



ETA Cracked Concrete



C1 Seismic Approval



Green Projects - LOW VOC



National Code Compliant



CODE BLUE

B+BTEC BIS-P Injection

Polyester - Fast Cure Styrene Free



When it's BLUE it's Polyester.

ICCONS® BIS-P is a Fast Cure, Styrene Free, Marine Grade Injection System for Anchoring Threaded Rod into Concrete, Hollow Brick and Block.

ETA Approved for use in Wet and Water Flooded Holes.



Concrete Temperature	Processing time	Curing Time	
		Dry Holes	Wet Holes
-5°C	90 min	6h	12 h
0°C	45 min	3h	6 h
+5°C	25 min	2 h	4 h
+10°C	15 min	80 min	160 min
+20°C	6 min	45 min	90 min
+30°C	4 min	25 min	50 min
+35°C	2 min	20 min	40 min



Part No.	Description	qty	qty
BIS-P420	420ml Injection Cartridge includes 2 x mixer nozzles	1	12
BIS-P300	300ml Injection Cartridge includes 2 x mixer nozzles	1	10
BIS-P420KIT	Installation kit consists of 1 x Dispensing Gun, 3 x 420ml BIS-V420, 1 x Blow Pump, 6 x Nozzles, 4 x Metal Brushes, 5 x Plastic Sleeves for M10 & M12	1	
BIS-P300KIT	Installation kit consists of 1 x Dispensing Gun, 4 x 300ml BIS-P300, 1 x Blow Pump, 6 x Nozzles, 4 x Metal Brushes, 5 x Plastic Sleeves for M10 & M12	1	
CNOZ10-V	Mixer Nozzle for BIS-V Vinylester & BIS-P Polyester (Pack of 10)	10	n/a

For compatible dispensing tools see page 77

Load Performance
Medium

Working Time
6 mins

Curing Time
45 mins

Wet Holes

Water Filled Holes

Overhead

Masonry /
Brickwork

Threaded
Studs

ETA
Approval

Green
Projects -
LOW VOC

NCC
NATIONAL CODE COMPLIANT

National Code
Compliant



CODE GOLD

B+BTEC VDP-Q Capsules



Vinylester - EXTREME STRENGTH



When it's GOLD it's a Capsule.

ICCONS® VDP-Q Capsules are the highest performing capsules available. Zero wastage, Fast Installation, Superior Performance and unmatched Cure Times for almost instant loading are just some of the VDP-Q benefits.

Fast 20min cure at 20°C dry concrete.



Usability

- Under Static Load.
- Under Vibratory Load.
- Suitable for Overhead Installation.

Concrete Temperature	Curing Time	
	Dry Holes	Wet Holes
-5°C	5h	10 h
+5°C	1 h	2 h
+20°C	20 min	40 min
+30°C	10 min	20 min

1-2-3-SAFETY

- 1 Volume Control**
Factory Pre-measured Components guarantee the correct composition and volume of capsule components. After installation of the rod, the overflow of anchor components provides visual confirmation of a 100% filled hole
- 2 Resin Check**
The transparent glass capsule allows the installer to check the quality of the resin. Usability is given when the resin runs easily inside then capsule at lukewarm temperature.
- 3 Auto Clean**
During the installation of the anchor rod the quartz and glass components of the capsule scrape the wall of the pre-drilled hole, removing drill dust. This Auto-Cleaning function results in an excellent adhesion between the Anchor Rod and surrounding Concrete.

Part No.	Description					
		mm	mm	mm	qty	qty
VDP-Q M8	8mm Glass Capsule to suit M8 Stud	10	80	17	10	500
VDP-Q M10	10mm Glass Capsule to suit M10 Stud	12	90	28	10	500
VDP-Q M12	12mm Glass Capsule to suit M12 Stud	14	110	36	10	200
VDP-Q M16	16mm Glass Capsule to suit M16 Stud	18	125	42	10	200
VDP-Q M20	20mm Glass Capsule to suit M20 Stud	22	170	72	10	100
VDP-Q M24	24mm Glass Capsule to suit M24 Stud	26	210	66	6	60

Load Performance
EXTREME

Working Time
Unlimited

Curing Time
20 mins

Wet Holes

Overhead

Masonry /
Brickwork

Threaded
Studs

ETA
Approval

Green
Projects -
LOW VOC

National Code
Compliant



385 & 585ml Dispensing tools

Suitable for BIS-PE

385 & 585ml Cartridges



CDISP-E



CDISP-MULTI



CDISP-EBAT



CPNEU-E

Part No.	Description	qty
CDISP-E	Suits both 385ml & 585ml Epoxy injection Cartridges	1
CDISP-MULTI	4 in 1 dispensing tool - Fits entire injection range	1
CDISP-EBAT	Battery Operated Cartridge Gun for 385ml & 585ml Epoxy Injection Systems	1
CPNEU-E	Pneumatic delivery system for 385 & 585ml Epoxy Adhesive - lead times apply check for availability.	1
CPNEU-E1400	Pneumatic delivery system for 1400ml Epoxy Adhesive - lead times apply check for availability.	1



420ml Dispensing tools

Suitable for BIS-HY, BIS-V & BIS-P

420ml Cartridges



CDISP-VP



CDISP-MULTI



CDISP-VPBAT



CPNEU-VP

Part No.	Description	qty
CDISP-VP	For 420ml injection cartridges - Hybrid, Vinylester & Polyester systems	1
CDISP-MULTI	4 in 1 dispensing tool - fits entire injection range	1
CDISP-VPBAT	For 420ml Injection cartridges - Hybrid, Vinylester & Polyester systems	1
CPNEU-VP	Pneumatic delivery system for 420ml Hybrid, Vinylester & Polyester - lead times apply check for availability.	1



280 & 300ml Dispensing tools

Suitable for BIS-HY, BIS-V & BIS-P

280ml & 300ml Cartridges



CDISP-S



CDISP-MULTI

Part No.	Description	qty
CDISP-S	Standard Caulking Gun suitable for 280ml & 300ml injection cartridges - Hybrid, Vinylester & Polyester systems	1
CDISP-MULTI	4 in 1 dispensing tool - fits entire injection range	1



ADHESIVES

CHEMSELECT CHEMSELECT CHEMSELECT CHEMSELECT CHEMSELECT CHEMSELECT

Mixer Nozzles - BIS-PE

For BIS-PE385 & 585ml tubes



Part No.	Description	qty	qty
CNOZ10-PE	Mixer Nozzle for BIS-PE Epoxy (includes extension nozzle) (Pack of 10)	10 pack	n/a

Mixer Nozzles - BIS-HY

For BIS-HY420



Part No.	Description	qty	qty
CNOZ10-HY	Mixer Nozzle for BIS-HY Hybrid (Pack of 10)	10 pack	n/a

Mixer Nozzles - BIS-V & BIS-P

For BIS-V420 & BIS-P420 & 300ml tubes



Part No.	Description	qty	qty
CNOZ10-V	Mixer Nozzle for BIS-V Vinylester & BIS-P Polyester (Pack of 10)	10 pack	n/a

1M Plastic Extension Tube

For Adhesive Nozzles



Part No.	Description	qty	qty
CNOZEXTN	1.0 metre Plastic Extension Tube for adhesive nozzles	1	10

Brushes

Hole preparation accessories

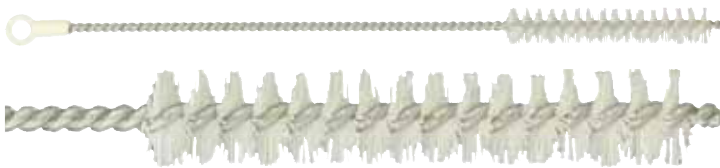

Part No.	Description	qty	qty
CBRU08-10	Brush to suit 8 - 10mm hole	1	n/a
CBRU10-14	Brush to suit 10 - 14mm hole	1	n/a
CBRU16-20	Brush to suit 16 - 20mm hole	1	n/a

Blow Pump

Hole preparation accessory



Part No.	Description	qty	qty
CPUMP	Industrial Blow Pump	1	n/a



ADHESIVES

CHEMSELECT CHEMSELECT CHEMSELECT CHEMSELECT CHEMSELECT CHEMSELECT



SDS Plus Adaptor

For use with Wire Brush & Extensions



Part No.	Description	qty	qty
CWBSDS	110mm long SDS Plus Adaptor for Wire Brush & Extension	1	n/a



Wire Brush Extension

Suits SDS Adaptor



Part No.	Description	qty	qty
CWBEXTN	290mm long Wire Brush Extension	1	n/a

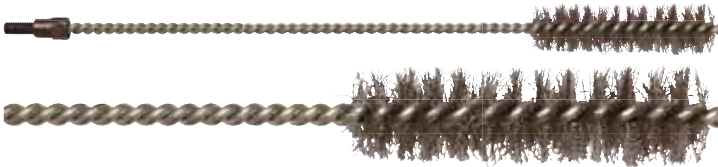

Wire Brush - 300mm

For use with SDS Plus Adaptor



Part No.	Description	mm	qty	qty
CWB18 (16091)	300mm long - Suits M16 Threaded Rod applications	18	1	n/a
CWB20 (16104)	300mm long - Suits N16 Rebar applications	20	1	n/a
CWB24 (16093)	300mm long - Suits M20 Threaded Rod and N20 Rebar applications	24	1	n/a
CWB28 (16095)	300mm long - Suits M24 Threaded Rod applications	28	1	n/a
CWB32 (16106)	300mm long - Suits N24 Rebar applications	32	1	n/a
CWB35 (16096)	300mm long - Suits M30 Threaded Rod and N28 Rebar applications	35	1	n/a
CWB37 (16097)	300mm long - Suits N32 Rebar applications	37	1	n/a
CWB40 (16130)	300mm long - Suits M36 Threaded Rod applications	40	1	n/a



Piston Plug

For deep embedment applications



Part No.	Description	mm	qty	qty
CPP18	Piston Plug suits 18mm drilled hole	18	10	n/a
CPP20	Piston Plug suits 20mm drilled hole	20	10	n/a
CPP24	Piston Plug suits 24mm drilled hole	24	10	n/a
CPP28	Piston Plug suits 28mm drilled hole	28	10	n/a
CPP35	Piston Plug suits 35mm drilled hole	35	10	n/a
CPP40	Piston Plug suits 40mm drilled hole	40	10	n/a

Instructions for Deep embedment installation

For new cartridges and/or nozzles, dispense a bead of adhesive until even and consistent colour is present to ensure correct mix of adhesive.

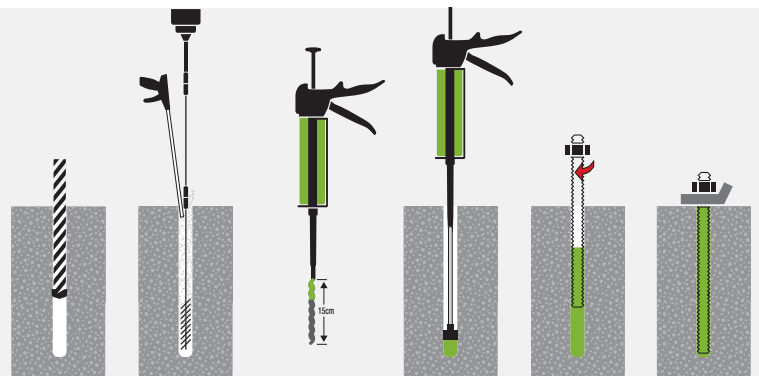



ADHESIVES

CHEMSELECT CHEMSELECT CHEMSELECT CHEMSELECT CHEMSELECT CHEMSELECT

CPS Threaded Studs

Threaded Adhesive Studs manufactured to industry standard lengths



■ Class 5.8 Carbon Steel Zinc Yellow

■ Class 5.8 Carbon Steel Galvanised

■ Stainless Steel 316 A4

Note: all information based on use with ICCONS adhesive systems only.

Part No.	Description		mm	mm	mm	head	metric	qty	qty	
CPS08110	CPS08110G	CPS08110SS	M8 x 110mm	10	80	17	Hex	M8	10	200
CPS10130	CPS10130G	CPS10130SS	M10 x 130mm	12	90	28	Hex	M10	10	200
CPS12160	CPS12160G	CPS12160SS	M12 x 160mm	14	110	36	Hex	M12	10	100
CPS16190	CPS16190G	CPS16190SS	M16 x 190mm	18	125	42	Hex	M16	10	50
CPS20260	CPS20260G	CPS20260SS	M20 x 260mm	*24	170	72	Hex	M20	5	25
CPS24300	CPS24300G	CPS24300SS	M24 x 300mm	*28	210	66	Hex	M24	5	20

For extreme corrosive environments HCR (High Corrosion Resistant) Stainless Steel Studs are also available on request - lead times may apply

*Drill diameter for use with BIS-HY injection & VDP-Q capsules is 22mm for M20 stud.

*Drill diameter for use with VDP-Q capsules is 26mm for M24 stud.

CFCHT High Tensile

NEW

■ Class 8.8 Carbon Steel HDG Galvanised

Note: all information based on use with ICCONS adhesive systems only.



Description		mm	mm	mm	metric	qty	qty
CFCHT12160G	M12 x 160mm	14	110	36	M12	10	100
CFCHT16190G	M16 x 190mm	18	125	42	M16	10	50
CFCHT20260G	M20 x 260mm	*24	170	72	M20	5	25
CFCHT24300G	M24 x 300mm	28	210	66	M24	5	20
#CFCHT30380G	M30 x 380mm	35	270	80	M30	TBA	TBA

#Larger sizes available upon request, lead times may apply

*Drill diameter for use with BIS-HY injection is 22mm for M20 stud.

CRE Reduced Embedment Studs

Reduced length for use with plastic or mesh sleeves

■ Class 5.8 Carbon Steel Galvanised



Part No.	Description	mm	metric	qty	qty
CRE10110G	M10 x 110mm - (short)	12	M10	10	200
CRE12110G	M12 x 110mm - (short)	14	M12	10	200
CRE16125G	M16 x 125mm - (short)	18	M16	10	100



ChemSelect CIS Threaded Inserts

Insert design allows use of various bolt head styles.



Flush finish.

Available M8 - M42 in Class 5.8 zinc & 316 (A4) SS.

Anchor profile performs like threaded rod.

Recommended for use with BIS-PE & BIS-HY ETA certified products.

Anti Rotation cut tip.



CIS Threaded Inserts

Class 5.8 Carbon Steel Zinc Clear

Stainless Steel 316 A4

For use with BIS-HY



ZINC INTERNAL 316 SS EXTERNAL

Part No.								
CIS08090		M8 X 90mm	14	M8	90	12	30	50
	CIS08090SS	M8 X 90mm Stainless Steel	14		90	12	30	5
CIS10090		M10 X 90mm	18	M10	90	16	35	30
	CIS10090SS	M10 X 90mm Stainless Steel	18		90	16	35	5
CIS12090		M12 X 90mm	22	M12	90	20	40	25
	CIS12090SS	M12 X 90mm Stainless Steel	22		90	20	40	5
CIS12125		M12 X 125mm	22		125	20	40	15
	CIS12125SS*	M12 X 125mm Stainless Steel	22		125	20	40	5
CIS16125		M16 X 125mm	28	M16	125	25	40	10
	CIS16125SS	M16 X 125mm Stainless Steel	28		125	25	40	5
CIS20180		M20 X 180mm	35	M20	180	30	60	5
	CIS20180SS	M20 X 180mm Stainless Steel	35		180	30	60	5



Chembolt™ Asphalt Fixing

For use with BIS-V

Carbon Steel Zinc Clear

Part No.	Description					
CBA10070	M10 x 70mm asphalt fixing (08116)	14	75	M10	15	50
CBA10100	M10 x 100mm asphalt fixing (08117)	14	105	M10	15	50
CBA12070	M12 x 70mm asphalt fixing (08118)	16	75	M12	20	50
CBA12100	M12 x 100mm asphalt fixing (08119)	16	105	M12	20	50



ADHESIVES

CHEMSELECT CHEMSELECT CHEMSELECT CHEMSELECT CHEMSELECT CHEMSELECT

Plastic Sleeve

For Hollow Base Materials



Part No.	Description	mm	mm	metric	qty	qty
CSP08050	8 x 50mm sleeve	12	50	M8	10	1000
CSP1012085	10 / 12 x 85mm sleeve	16	85	M10 / M12	10	2000
CSP1012130	10 / 12 x 130mm sleeve	16	130	M10 / M12	10	1500
CSP16085	16 x 85mm sleeve	20	85	M16	10	2000

Mesh Sleeve

One Metre Long



Part No.	Description	mm	mm	metric	qty	qty
CSM121000	11 x 1000mm - Mesh Sleeve	12	1000	M8	1	50
CSM161000	15 x 1000mm - Mesh Sleeve	16		M10 / M12	1	50
CSM221000	21 x 1000mm - Mesh Sleeve	22		M16	1	25

Installation instructions

Hollow base material

For new cartridges and/or nozzles, dispense a bead of adhesive until even and consistent colour is present to ensure correct mix of adhesive.

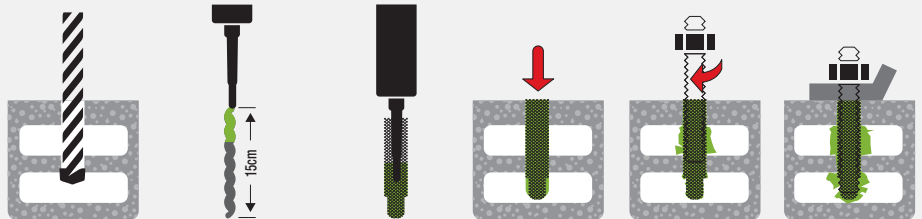

Retainer Cap



Part No.	Description	mm	metric	qty	qty
CAP10	10mm Retainer Cap	12	M10	10	n/a
CAP12	12mm Retainer Cap	14	M12	10	n/a
CAP16	16mm Retainer Cap	18	M16	10	n/a
CAP20	20mm Retainer Cap	24	M20	10	n/a

Installation instructions

Retainer Cap overhead installations

For new cartridges and/or nozzles, dispense a bead of adhesive until even and consistent colour is present to ensure correct mix of adhesive.

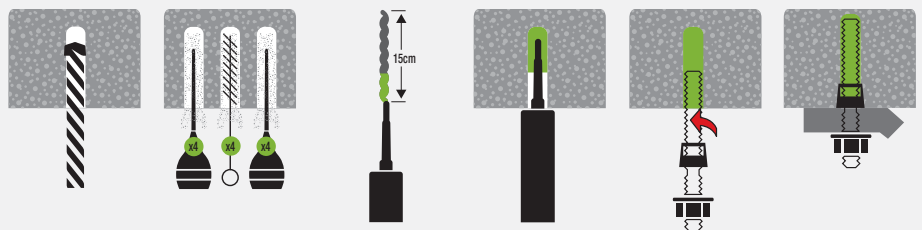



ADHESIVES



FoamFlo® F750

Expanding PU Foam - Straw Delivery System



Part No.	Description	qty	qty
F750	750ml - FoamFlo® Polyurethane B3 expanding foam straw nozzle manual delivery system	1	12
FOAMFLO-CLEANER	500ml - FoamFlo® Cleaner for PU foam and tool	1	12

FoamFlo® FT750

Expanding PU Foam - Tool Delivery System



FT-PROTOOL

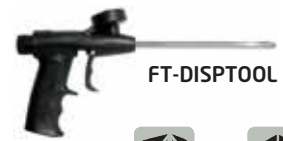

FT-DISPTOOL



Part No.	Description	qty	qty
FT750	750ml - FoamFlo® Polyurethane B3 expanding foam for tool delivery system	1	12
FOAMFLO-CLEANER	500ml - FoamFlo® Cleaner for PU foam and tool	1	12
FT-PROTOOL	FoamFlo® Professional dispensing tool for PU foam (49906000000)	1	n/a
FT-DISPTOOL	FoamFlo® Disposable dispensing tool for PU foam (49906000001)	1	n/a



FoamFlo® FIRE

*Fire Retardant expanding PU foam- straw delivery system



Part No.	Description	qty	qty
FOAMFLO-FIRE	750ml - Foamflo® Fire Retardant expanding PU foam- straw nozzle delivery system	1	12
FOAMFLO-CLEANER	500ml - FoamFlo® Cleaner for PU foam and tool	1	12

*Fire Resistant Applications: Fire resistant sealing between concrete walls (vertical penetrations), see www.iccons.com.au for full details.



WHITE

GREY

BLACK

All Rounder™

- All round polymer sealant that Seals, Bonds & fills gaps.
- Adheres to a wide variety of materials including.
- Timber. Concrete. Stone. Galvanised Steel. Aluminium.
- Brick. Plasterboard. Mirrors. Particleboard. Laminate.
- Polystyrene. Fibreglass. Ceramic. Some Plastics.



Part No.	Part No.	Part No.	Description	qty	qty
ARW300	ARG300	ARB300	290ml - All Rounder™ polymer sealant / adhesive	1	12

FAST & EASY
TO USE



GT Applications

- Direct Fixing to Metal Stud Partitioning, Floors, Walls and Ceilings
- Furring Channel Clips
- Angle Clips for ceiling rod suspension systems
- Fire Rated Angle Clips for fire rated cabling
- Insulation Fasteners (GTI-140C only)

GT-6 Gas Tool

Long & Short Track

Gas fastening systems are now utilised by many construction professionals for a wide range of applications as they are fast and easy to use.



Part No.	Description	qty
GT-6	Long track (40 pin capacity) - Kit includes GT-6 tool, charger, 2 x Li-Ion batteries, safety glasses & instruction booklet	1
GT-6ST	Short track (30 pin capacity) - Kit includes GT-6ST tool, charger, 2 x Li-Ion batteries, safety glasses & instruction booklet	1

GT Extension Pole (6 Foot)

Suitable For GT6 & GTI-140C



Part No.	Description	qty
GT-POLE4	6' Pole Tool kit (Includes handle, head and 280mm, 580mm & 690mm pole extensions)	1
Accessories		
GT-POLE1	Extension Pole (280mm)	1
GT-POLE2	Extension Pole (580mm)	1
GT-POLE3	Extension Pole (690mm)	1



GT-6 Pin & IXF-24+ Fuel Cell



Standard pin (also fits ICCONS® GT3 Tools)



Part No.	Description	qty	qty
GT6-20	20mm - Pin & Fuel Cell	1000	5000
GT6-25	25mm - Pin & Fuel Cell	1000	5000
GT6-35	35mm - Pin & Fuel Cell	1000	5000

GT-6 HC Pin & IXF-24+ Fuel Cell



Ballistic Point Pin Hardened Pin For Hard Substrates (also fits ICCONS® GT3 Tools)



Part No.	Description	qty	qty
GT6-HC15	15mm - ballistic point pin (for hard concrete) & Fuel Cell	1000	5000
GT6-HC17	17mm - ballistic point pin (for hard concrete) & Fuel Cell	1000	5000
GT6-HC22	22mm - ballistic point pin (for hard concrete) & Fuel Cell	1000	5000

NEW

IXF-24+ Fuel Cell



- 24+ month Shelf Life
- 100% QA - Every Cell & Every Valve is Pressure Tested
- Includes Spacer to fit other Tools (if required)

Fuel Cell only - suits GT6, GT3 & GT140C (Supplied spacer required for GT3 & GT140C)



Part No.	Description	qty	qty
GT-IXF-24+	GT Fuel Cell only	1	12

NEW

GT-3 Pin & IXF-24+ Fuel Cell



Suitable for ICCONS® GT-3 (Supplied spacer required).
Ramset™ Trakfast™ TF1200 & Powers® Trak-It® C3 tools



Part No.	Description	qty	qty
GT20	20mm - Pin & Fuel Cell	1000	5000

NEW

GT-3 HC Pin & IXF-24+ Fuel Cell



Suitable for ICCONS® GT-3 (Supplied spacer required).
Ramset™ Trakfast™ TF1200 & Powers® Trak-It® C3 tools



Part No.	Description	qty	qty
GTHC15	15mm - ballistic point pin (for hard concrete) & Fuel Cell	1000	5000
GTHC17	17mm - ballistic point pin (for hard concrete) & Fuel Cell	1000	5000
GTHC22	22mm - ballistic point pin (for hard concrete) & Fuel Cell	1000	5000



NEW

ICCONS® IXF-24+C5 Fuel Cell

- 24+ month Shelf Life
- 100% QA - Every Cell & Every Valve is Pressure Tested
- Includes Spacer to fit other Tools (if required)

For use in Powers® C5 & Max GS738C Tools



Part No.	Description	qty	qty
GT-IXF-24+C5	GT-5 Fuel Cell	20	80

ICCONS® GT-C5

Standard Pins & IXF-24+ Fuel Cell

For use in Powers® C5 Tool & Max GS738C Tools



Part No.	Description	mm	mm	qty	qty
GT5-20	C5 PIN & Fuel Cell Combo 20MM (70086)	20	2.6	800	4000

ICCONS® GT-C5

Extra Hard Pins & IXF-24+ Fuel Cell

For use in Powers® C5 Tool & Max GS738C Tools



GT5-17HC	C5 Pin & Fuel Cell Combo 17MM Hard Concrete (17XH - 70096)	17	3.0	800	4000
GT5-22HC	C5 PIN & Fuel Cell Combo 22MM Hard Concrete (22XH - 70100)	22	3.0	800	4000

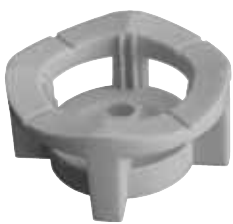

apolo GT-C5 Cable Tie Mounts

For use in Powers® C5 Tool



Part No.	Description	qty	qty
GT5CTM	GT-5 Cable Tie Mounts (9NTBB)	100	900

Follow Us



Facebook
ICCONS Pty Ltd



Instagram
iccons.ptyltd



LinkedIn
ICCONS Pty Ltd



apolo GTMAC Metal Angle

Fits ICCONS® GT-6 Tools & Powers® C5



Part No.	Description	qty	qty
GTMAC-FR	Fire Rated - Metal Angle Clip for GT-6 Tools	100	900

GT Metal Angle Clip

Fits ICCONS® GT-6 & GT3 Tools



GTMAC



GTMAC-GT6AD



Part No.	Description	qty	qty
GTMAC	Metal Angle Clip for GT-6 & GT-3 Tools (use with GTMAC-GT6AD)	100	800
GTMAC-GT6AD	GT-6 Magnetic adaptor for use with GTMAC Metal Angle Clip (also compatible with GT-3 tools)	1	n/a

GT-3 Metal Washers & Adaptor

Fits ICCONS® GT-6 & GT3 Tools



Part No.	Description	qty	qty
GTW14	14mm O.D Metal Washer (use with GTMA-14W)	250	5000
GTMA-14W	Magnetic Adaptor for use with 14mm O.D metal washer (suitable for GT-6 & GT-3 Tools)	1	n/a
GTW25	25mm O.D Metal Washer (use with GTMA-25W)	250	5000
GTMA-25W	Magnetic Adaptor for use with 25mm O.D metal washer (suitable for GT-6 & GT-3 Tools)	1	n/a



GT3CTM

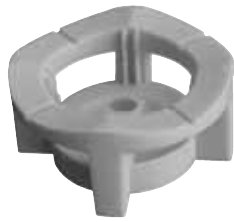

GT5CTM

apolo Cable Tie Mount

Apolo Cable Tie Mounts suitable for use with GT-3 & GT6 Gas Tool



Part No.	Description	Colour	qty	qty
GT3CTM	Cable Tie Mount (9TBB GT3CTM) for GT3 tools	Black	100	900
GT5CTM	Cable Tie Mount (9NTBB GT5CTM) for GT6 & Powers® C5 Tools	Grey	100	900



Contractors Packs

Consists of:



Part No.	Description	qty
GT6-CTP1	CONTRACTORS TRADE PACK - GT6-HC22 (1000pce), GT5CTM (1000pce), GTCT200 (1000pce)	1
GT6-CTP2	CONTRACTORS TRADE PACK - GT6-HC17 (1000pce), GT5CTM (1000pce), GTCT200 (1000pce)	1
GT6-CTP3	CONTRACTORS TRADE PACK - GT6-HC15 (1000pce), GT5CTM (1000pce), GTCT200 (1000pce)	1
GT6-CTP4	CONTRACTORS TRADE PACK - GT6-20 (1000pce), GT5CTM (1000pce), GTCT200 (1000pce)	1

* Other combinations are available on request

Cable Tie 180mm x 4.5mm



- Nylon Cable tie
- Polyamide 6.6 Halogen & Silicon Free
- Halogen-free, self-extinguishing V2: UL 94
- Resistant to solvents and reagents, oil, petrol, and hydrocarbons
- 280N /28kg load
- Suitable for applications Ø 3 - 45mm



Made in Italy



Part No.	Description	qty	qty
GTCT200	Cable Tie 180mm x 4.5mm Black	100	n/a



- Quick installation, good grip
- Ideal for electrical applications such as cable channels, junction boxes, etc.

apolo MAS Nylon Plug



Nylon plug direct fixing

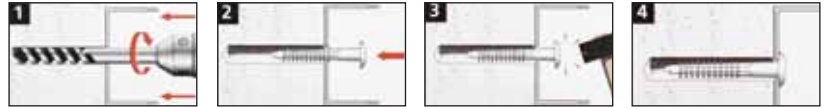

NYLON



Part No.	Description	mm	mm	qty	qty
GTMAS06040	6 x 40mm Nylon Plug (91640MAS)	6	32	200	1800



apolo Conduit Saddle



Suitable for use with GT-3 & GT6 Gas Tools



Part No.	Part No.	Description	mm	qty	qty
GTPVC16		16mm PVC Single Conduit Saddle (FP16)	16	100	600
GTPVC20		20mm PVC Single Conduit Saddle (FP20)	20	100	600
GTPVC25		25mm PVC Single Conduit Saddle (FP25)	25	100	600
	GTMT25	25mm Metal Single Conduit Saddle (FT-25) - Fire Rated	25	100	900

apolo Quick Clip Self Locking Polyamide Pipe Clamp



Suitable for use with GT-3 & GT6 Gas Tools or with apolo Channel Strut systems.



Part No.	Description	mm	qty	qty
GTQC14-18	Quick Clip Self Locking Pipe Clamp (ABT18)	14-18	100	600
GTQC20-25	Quick Clip Self Locking Pipe Clamp (ABT25)	20-25	50	450
GTQC26-32	Quick Clip Self Locking Pipe Clamp (ABT32)	26-32	50	300
GTQC35-42	Quick Clip Self Locking Pipe Clamp (ABT42)	35-42	25	150



Distributors : Quick Clip display board available upon request



apolo Channel Strut for Quick Clip System



Part No.	Description	mm	mm	Metre	qty	qty
CSPVC	PVC Channel Strut for Quick Clip System (P1000PVC)	25	11	1	1	30
CSM	Metal Channel Strut for Quick Clip System (2000PG)	20	8	2	1	24



COMPACT

Insulation Fastening Tool

For Fastening Rigid Board & Soft Insulation Board To Concrete



- LIGHTER
- QUIETER
- FASTER
- SAFER
- POWERFUL

GTI-140C Insulation Gas Tool

Compact Gas Operated tool for shooting insulation washers

FEATURES

- For all types of insulation fixing
- Quick and easy insulation fixing
- Fixing on hollow brick without damage to the base material
- PAT replacement
- Durable Fuel Cell



Part No.	Description	qty
GTI-140C	Compact Insulation Tool - Kit includes GTI-140C tool, charger, 2 x batteries, safety glasses & instruction booklet	1

GTI-140C



NEW

IXF 24+ Fuel Cell

- 24+ month Shelf Life
- 100% QA - Every Cell & Every Valve is Pressure Tested
- Includes Spacer to fit other Tools (if required)

Fuel Cell only - suits GT6, GT3 & GT140C (Supplied spacer required for GT3 & GT140C)



Part No.	Description	qty	qty
GT-IXF-24+	GT Fuel Cell only	1	12



NEW SIZES

GTI-140C Insulation Fasteners

For GTI-140C Gas nailer

Not suitable for fire rated applications, see page 60 for fire rated solutions

WHITE

BLACK



Part No.	Description	mm	mm	qty	qty
GTIF025	GTIFB025 NEW Insulation Fastener with drive pin for 25mm insulation	25	60	50	1000
GTIF030	Insulation Fastener with drive pin for 30mm insulation	30	60	50	1000
GTIF035	Insulation Fastener with drive pin for 35mm insulation	35	60	50	1000
GTIF040	GTIFB040 NEW Insulation Fastener with drive pin for 40mm insulation	40	60	50	1000
GTIF050	Insulation Fastener with drive pin for 50mm insulation	50	60	50	900
GTIF060	Insulation Fastener with drive pin for 60mm insulation	60	60	50	800
GTIF075	GTIFB075 NEW Insulation Fastener with drive pin for 75mm insulation	75	60	25	600
GTIF080	Insulation Fastener with drive pin for 80mm insulation	80	60	25	600
GTIF090	Insulation Fastener with drive pin for 90mm insulation	90	60	25	500
GTIF100	Insulation Fastener with drive pin for 100mm insulation	100	60	25	500
GTIF120	Insulation Fastener with drive pin for 120mm insulation	120	60	25	400
GTIF130 NEW	Insulation Fastener with drive pin for 130mm insulation	130	60	25	300

Not suitable for fire rated applications. Other sizes available on request.



GT Extension Pole (6')



Part No.	Description	qty
GT-POLE4	6' Pole Tool kit (Includes Handle, head and 280mm, 580mm & 690mm pole extensions)	1
Accessories		
GT-POLE1	Extension Pole (280mm)	1
GT-POLE2	Extension Pole (580mm)	1
GT-POLE3	Extension Pole (690mm)	1

DURABILITY:
Resilient Light Weight One Piece Engineered housing made from glass reinforced Nylon 6.

ACCURACY:
Easy Adjust Power Dial regulates nail penetration.

RELIABILITY:
Simple design allows a fast dismantle / reassemble procedure for easy cleaning and maintenance

VERSATILITY:
Fastener designed to accept PX nails up to 75mm , and a variety of clip assemblies.



POWERFUL SEMI-AUTOMATIC:
Accepts .27 Caliber 10 charge safety strip.

COMFORT:
Contoured Shock Absorbing Rubber Grip reduces operator fatigue.

SAFETY:
2 stage trigger - tool has to be depressed against base materiel before it will activate.

SECURE:
Tough moulded lockable case with compartments to store your charges , safety glasses and cleaning equipment



PX375 Powder Actuated Tool

.27 caliber low velocity semi automatic tool up to 75mm nails

Kit includes - PX375 Tool, 1 x rubber nose piece stabiliser, cleaning brushes, 1 x safety glasses & instruction booklet.



PX375



P95



P96



P96

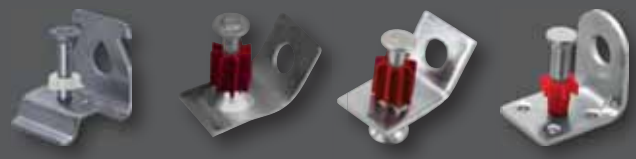

P97

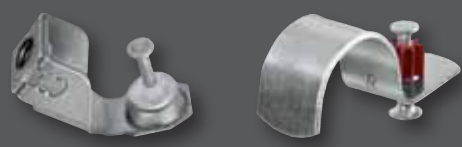

P98



P98



Part No.	Description	qty
PX375	Powder Actuated Tool - .27 caliber low velocity semi automatic tool up to 75mm nails	1
PX350-CLEANINGKIT	Cleaning Kit for PX375	1

* Not suitable for PX60M Tools



PXC - Collated Drive Pin - 8mm Head

For use with ICCONS® PX60M (magazine) (PX60M will need 1 x rubber spring / 500 nails)
Also suits most brands with magazine attachment, suitable for 8mm barrel.



Part No.	Description	mm	mm	mm	qty	qty
PXC16M	16mm Collated 10 strip Drive Pin	8	16	3.8	100	1600
PXC19M	19mm Collated 10 strip Drive Pin		19	3.8	100	1600
PXC22M	22mm Collated 10 strip Drive Pin NEW		22	3.8	100	1600
PXC27M	27mm Collated 10 strip Drive Pin		27	3.8	100	1600
PXC32M	32mm Collated 10 strip Drive Pin		32	3.8	100	1600
PXC37M	37mm Collated 10 strip Drive Pin		37	3.8	100	1600
PXC42M	42mm Collated 10 strip Drive Pin		42	3.8	100	1600
PXC52M	52mm Collated 10 strip Drive Pin		52	3.8	100	1600
PXC62M	62mm Collated 10 strip Drive Pin		62	3.8	100	1600
PXC72M*	72mm Collated 10 strip Drive Pin		72*	3.8	100	1600

* Not suitable for PX60M Tools

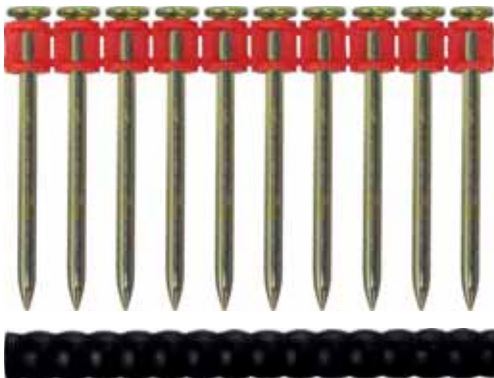

PX9C - Collated Drive Pin - 9mm Head With Rubber Spring

Suitable for Ramset® FrameBoss™ Tools, & Powers® P3X



Part No.	Description	mm	mm	mm	qty	qty
PX9C20MRS	20mm Collated 10 strip Drive Pin with Rubber Spring	9	20	3.7	500	2500
PX9C50MRS	50mm Collated 10 strip Drive Pin with Rubber Spring		50	3.7	300	1500
PX9C60MRS	60mm Collated 10 strip Drive Pin with Rubber Spring		60	3.7	300	1500
PX9C75MRS	75mm Collated 10 strip Drive Pin with Rubber Spring		75	3.7	300	1500

PX - Rubber Spring

Suitable for use with ICCONS® PX60M & Ramset® FrameBoss™ Tools



Part No.	Description	qty	qty
PXMRS	Rubber Spring	1	n/a



PXS - Drive Pin - 8mm Head

For use with ICCONS® PX350, PX375 & PX60M Tools (single shot).
Suits most brands of low velocity powder actuated tools.



Part No.	Description	mm	mm	mm	qty	qty
PXS16	16mm Drive Pin	8	16	3.7	100	1000
PXS19	19mm Drive Pin		19	3.7	100	1000
PXS25	25mm Drive Pin		25	3.7	100	1000
PXS32	32mm Drive Pin		32	3.7	100	1000
PXS38	38mm Drive Pin		38	3.7	100	1000
PXS45	45mm Drive Pin		45	3.7	100	1000
PXS50	50mm Drive Pin		50	3.7	100	1000
PXS57	57mm Drive Pin		57	3.7	100	1000
PXS60	60mm Drive Pin		60	3.7	100	1000
PXS65	65mm Drive Pin		65	3.7	100	1000
PXS70	70mm Drive Pin		70	3.7	100	1000
PXS75	75mm Drive Pin		75	3.7	100	1000
*PXS99	100mm Drive Pin		100	3.7	100	1000

* Not suitable for PX350, PX375 or PX60M tools, - Suitable for Ramset® FrameBoss™

PXSC - Ballistic Point - 8mm Head



Ballistic Point for Hard Concrete & Steel

For use with ICCONS® PX350, PX375 & PX60M Tools (single shot).
Suits most brands of low velocity powder actuated tools.



Part No.	Description	mm	mm	mm	qty	qty
PXSC50	50mm Ballistic Stepped point Drive Pin	8	50	4	100	1000
PXSC60	60mm Ballistic Stepped point Drive Pin		60	4	100	1000
PXSC75	75mm Ballistic Stepped point Drive Pin		75	4	100	1000

PHV Drive Pin - 6mm Head



High Velocity

Suits most brands of high velocity powder actuated tools



Part No.	Description	mm	mm	mm	qty	qty
PHV50	50mm x 6mm Head - Drive Pin	6	50	3.7	100	1000
PHV65	65mm x 6mm Head - Drive Pin		65	3.7	100	1000
PHV75	75mm x 6mm Head - Drive Pin		75	3.7	100	1000
PHV90	90mm x 6mm Head - Drive Pin		90	3.7	100	1000



PXSCW - Cane Bin Washered Pin

For use with ICONS® PX350, PX375 & PX60M Tools (single shot)

Suits most brands of low velocity powder actuated tools.



Part No.	Description	mm	mm	mm	qty	qty
PXSCW25	25mm Ballistic Point Drive Pin with 16mm washer	8	25	3.7	100	800



PXTH - Top Hat Assembly

For use with ICONS® PX350, PX375 & PX60M Tools (single shot)

Suits most brands of low velocity powder actuated tools.



Part No.	Description	mm	mm	mm	qty	qty
PXTH16	16mm Drive Pin with Top Hat Assembly	8	16	3.7	100	1000
PXTH19	19mm Drive Pin with Top Hat Assembly		19	3.7	100	1000
PXTH25	25mm Drive Pin with Top Hat Assembly		25	3.7	100	1000

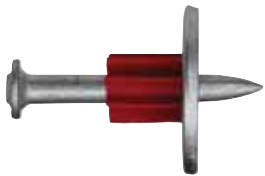

PXW - Metal Washer Assembly

For use with ICONS® PX350, PX375 & PX60M Tools (single shot)

Suits most brands of low velocity powder actuated tools.



Part No.	Description	mm	mm	mm	mm	qty	qty
PXW25	25mm Drive Pin with 22mm Washer	8	25	3.7	22	100	1000
PXW32	32mm Drive Pin with 22mm Washer		32	3.7	22	100	1000
PXW38	38mm Drive Pin with 22mm Washer		38	3.7	22	100	1000



PXWTH - Metal Washer with Top Hat

For use with ICONS® PX350, PX375 & PX60M Tools (single shot)

Suits most brands of low velocity powder actuated tools.



Part No.	Description	mm	mm	mm	mm	qty	qty
PXWTH20	20mm Drive Pin with 22mm Washer	8	20	3.7	22	100	1000
PXWTH25	25mm Drive Pin with 22mm Washer		25	3.7	22	100	1000
PXWTH30	30mm Drive Pin with 22mm Washer		30	3.7	22	100	1000

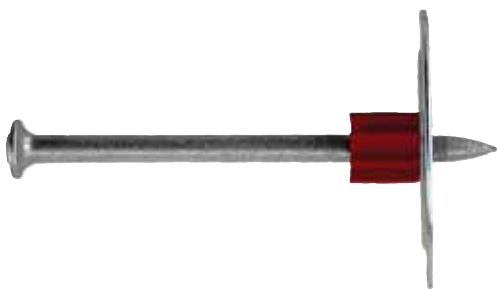

PXIW - Metal Insulation Washer

For use with ICONS® PX350, PX375 & PX60M Tools (single shot)

Suits most brands of low velocity powder actuated tools.



Part No.	Description	mm	mm	mm	mm	qty	qty
PXIW38	38mm Drive Pin with 36mm Insulation washer	8	38	3.7	36	100	1000
PXIW65	65mm Drive Pin with 36mm Insulation washer		65	3.7	36	50	500



PXIF - Insulation Fasteners

Suits most brands of low velocity powder actuated tools fitted with an insulation fastener adaptor



Part No.	Description	mm	qty	qty
PXIF025	Insulation Fastener with 37mm Drive Pin for 25mm insulation	25	300	n/a
PXIF030	Insulation Fastener with 42mm Drive Pin for 30mm insulation	30	300	n/a
PXIF035	Insulation Fastener with 42mm Drive Pin for 35mm insulation	35	300	n/a
PXIF040	Insulation Fastener with 52mm Drive Pin for 40mm insulation	40	300	n/a
PXIF050	Insulation Fastener with 52mm Drive Pin for 50mm insulation	50	300	n/a
PXIF060	Insulation Fastener with 52mm Drive Pin for 60mm insulation	60	200	n/a
PXIF075	Insulation Fastener with 52mm Drive Pin for 75mm insulation	75	200	n/a
PXIF100	Insulation Fastener with 52mm Drive Pin for 100mm insulation	100	200	n/a

Other sizes available on request



PXCC - Angle Clip

For use with ICCONS® PX350, PX375 & PX60M Tools (single shot)

Suits most brands of low velocity powder actuated tools.



Part No.	Description	mm	mm	mm	qty	qty
PXCC27	PX - Drive Pin 27mm with Angle Clip	8	27	3.7	100	1000



PXCC25	25mm Drive Pin with Angle Clip	8	25	3.7	100	1000
PXCC32	32mm Drive Pin with Angle Clip		32	3.7	100	1000
PXCCT25	25mm Drive Pin washered - Angle Clip with Top Hat		25	3.7	100	1000



PXCCSC - Angle Clip - Ballistic Point

Ballistic Point Drive Pin for Hard Concrete and Steel

For use with ICCONS® PX350, PX375 & PX60M Tools (single shot)

Suits most brands of low velocity powder actuated tools.



Part No.	Description	mm	mm	mm	qty	qty
PXCCSC25	PX - Drive Pin 25mm Ballistic with Angle Clip	8	25	3.7	100	1000
PXCCSC32	PX - Drive Pin 32mm Ballistic with Angle Clip		32	3.7	100	1000



PXTR - M10 Threaded Rod Hanger

For use with ICONS® PX350, PX375 & PX60M Tools (single shot)
Suits most brands of low velocity powder actuated tools.



Part No.	Description	mm	mm	mm	qty	qty
PXTRM10	M10 Rod Hanger Assembly with 27mm Twist Shank Drive Pin	8	27	3.7	50	600



PXCON - Conduit Clip - Metal

For use with ICONS® PX350, PX375 & PX60M Tools (single shot)
Suits most brands of low velocity powder actuated tools.



Part No.	Description	mm	mm	mm	mm	qty	qty
PXCON25	25mm Conduit Clip - Metal with 25mm Drive Pin	8	25	3.7	25	25	250



PXCT - Cable Tie Assembly

For use with ICONS® PX350, PX375 & PX60M Tools (single shot)
Suits most brands of low velocity powder actuated tools.



Part No.	Description	mm	mm	mm	mm	qty	qty
PXCT240	240mm Cable Tie with 32mm Drive Pin	8	32	3.7	240	500	n/a



Angle Clip

No Pin

ZINC INTERNAL



Part No.	Description	qty	qty
PACCNP	Angle Clip - 8mm & 7mm holes - No Pin	100	1000



Knurled Shank Masonry Nail

Zinc Clear

ZINC INTERNAL



Part No.	Description	mm	mm	qty	qty
KMN25	3.7 x 25mm	25	3.7	100	2000
KMN40	3.7 x 40mm	40	3.7	100	1000
KMN50	3.7 x 50mm	50	3.7	100	1000
KMN65	3.7 x 65mm	65	3.7	100	1000
KMN75	3.7 x 75mm	75	3.7	100	1000

* Also referenced on Page 68



Mickey Pins

Zinc Clear

ZINC INTERNAL



Part No.	Description	mm	mm	qty	qty
MPW20	Washed Mickey Pin hand drive nail - 20 x 2.5mm	20	2.5	500	5000
MPW25	Washed Mickey Pin hand drive nail - 25 x 2.5mm	25	2.5	500	5000
MPW30	Washed Mickey Pin hand drive nail - 30 x 2.5mm	30	2.5	500	5000
MPW40	Washed Mickey Pin hand drive nail - 40 x 2.5mm	40	2.5	500	4000
MPW50	Washed Mickey Pin hand drive nail - 50 x 2.5mm	50	2.5	500	4000

* Also referenced on Page 68



PXLS - Load Safety Strip - .27 Caliber

For use with ICCONS® PX350, PX375 & PX60M Tools
Suits most brands of low velocity powder actuated tools.



Part No.	Part No.	Part No.	Description	qty	qty
PXLSG (3LVS27)	PXLSY (4LVS27)	PXLSR (5LVS27)	.27 Caliber 10 load safety strip	100	1000

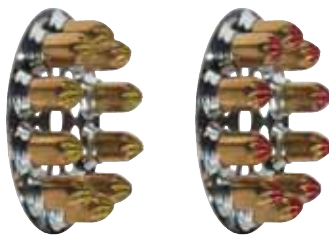

PXLD - Load Disk - .25 Caliber

For use with ICCONS® PX60M Tools & Powers® P3X



Part No.	Part No.	Description	qty	qty
PXLDY (4060)	PXLDR (5060)	.25 Caliber 10 load disk	100	1000



PSV - Load Single - .22 Caliber

For High Velocity Tools



Part No.	Part No.	Part No.	Description	qty	qty
PSVY (22LRSC4)	PSVR (22LRSC5)	PSVP (22LRSC6)	.22 High Velocity load - Single	100	1000

Scell-it®

ICCONS® through its "Serious Connections" brings European designed and sourced products with its new range of Blind Rivets.

Partnering with Scell-it® from France and with the focus on advanced design, high grade alloy metals, precise manufacturing and total quality control you can be assured that the ICCONS range of blind rivets are of the highest European design and quality.



ICCONS Blind Rivet Components

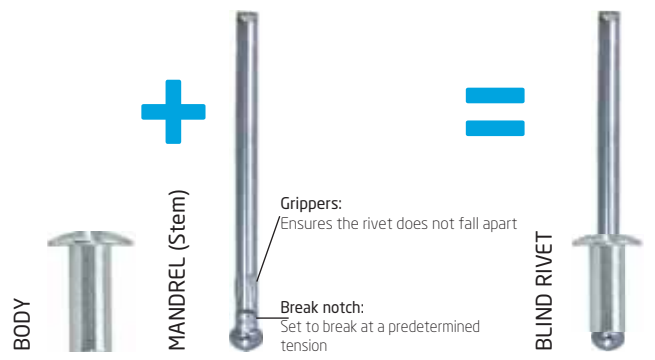

RIVET BODY	BASE MATERIAL COMPATIBILITY					
	Aluminium	Alu / AZ Coated Steel	Zinc coated steel	Stainless Steel	Copper	Brass
Aluminium	Compatible	Compatible	Compatible in mild environments	Not compatible	Not compatible	Not compatible
Steel	Not compatible	Compatible	Compatible	Not compatible	Not compatible	Not compatible
Stainless Steel	Compatible in mild environments	Compatible in mild environments	Compatible in mild environments	Compatible	Compatible	Compatible

● **Compatible**
 ● **Not compatible** (Must not make contact)
 ● Compatible in mild environments, Some corrosion may occur in corrosive environments painting both metals will reduce reaction.

	Rivet Code	Rivet Specification	Application description	Page	
RIVETS	WEAKEST	AS	Body - 5050 Grade Aluminium Alloy Mandrel - Zinc Plated Steel	For general applications where a lower tensile product is adequate. Applications could include guttering, downpipes, letter boxes etc. ICCONS also range the standard Colorbond® colours in the AS4-3 and AS5-4 rivet sizes.	102
		ASL	Body - 5056 Grade Aluminium Alloy Mandrel - Zinc Plated Steel	Suitable for applications where soft or composite materials such as timber, plastic or fibreglass are being fixed to metal.	102
		AS (CSK)	Body - 5056 Grade Aluminium Alloy Mandrel - Zinc Plated Steel	Suitable for those applications where a flush finish is required.	103
	AA	Body - 5052 Grade Aluminium Alloy Mandrel - Aluminium Alloy	The All Aluminium rivet range is great for those applications where the corrosion of a steel mandrel is not acceptable.	103	
	ASMG	Body - 5052 Grade Aluminium Alloy Mandrel - Zinc Plated Steel	The Multi Grip rivet covers a wider grip range than a standard shell rivet. Up to 3 sizes of rivet can be substituted for 1 Multi Grip rivet allowing users to carry a smaller range of inventory.	104	
	TA	Body - 5056 Grade Aluminium Alloy Mandrel - Phosphated Steel	The ICCONS sealed rivets are typically used in applications such as ducting, water tanks, boat building etc where a water or airtight joint is required.	104	
	SS	Body - 1010 Grade steel zinc plated Mandrel - Zinc Plated Steel	The all steel rivets provide a strong connection in steel applications such as steel framed homes, internal steel partitioning, or manufacturing of products such as ladders or garage doors.	105	
STRONGEST	STST	Body - 304 Grade Stainless Steel Mandrel - 304 Grade Stainless Steel	ICCONS all stainless rivets provide the strongest connection and are used in applications such as kitchen wash basins, stainless bathroom fixtures etc.	105	



Understanding ICCONS® Rivet Codes

ICCONS® Blind Rivet part numbers contain information about the Rivet i.e. head style, material, diameter code & grip code etc.

Example part number: **RD-ASMG41.3**

R	D	-	A	S	MG	4	1.3	
Prefix for ICCONS Rivet Range	Head Style		Rivet Body Code	Mandrel (Stem) Code	Extra Code for Special Rivets	Rivet Body Diameter Code	Grip Code	
Groups rivets together when searching in computer systems	D Dome Head C Countersunk		A Aluminium S Steel ST Stainless Steel TA Sealed Rivet	A Aluminium S Steel ST Stainless Steel	MG Multi Grip L Large Flange	4 3.2mm 5 4.0mm 6 4.8mm 8 6.4mm	1 0.5 to 1.6mm 2 1.6 to 3.2mm 3 3.2 to 4.8mm 4 4.8 to 6.4mm 5 6.4 to 7.9mm	6 7.9 to 9.5mm 8 9.5 to 12.7mm 10 12.7 to 15.9mm 12 15.9 to 19.0mm
							Grip Code for Multi Grip Rivets	
							1.3 0.8 to 4.8mm	4.7 6.4 to 12.7mm
							1.4 1.2 to 6.4mm	5.6 4.0 to 9.5mm
							4.5 4.0 to 7.9mm	7.9 11.1 to 13.7mm



All ICCONS® 4,5 & 6 series Rivets have a bonus 2x panel bits included in each box
LOOK FOR THIS STICKER!

PROFESSIONAL RIVET TOOLS AVAILABLE



SEE PAGES 106 - 107 FOR DETAILS

RIVETS

Aluminium / Steel - Dome Head

Body - Aluminium

Mandrel - Steel

Scell-it®



RIVET	Part No.	Part No.	Drill	Body Dia	Length (mm)	Grip Range	Newton's	Newton's	qty	qty				
4-1	RD-AS41		3.3mm (#30)	3.2mm (1/8)	5.4	0.5 - 1.6	530	670	1000	10 000				
4-2	RD-AS42				7.0	1.6 - 3.2			1000	10 000				
4-3	RD-AS43*				8.6	3.2 - 4.8			1000	10 000				
4-4	RD-AS44	RD-ASL44			10.2	4.8 - 6.4			1000	10 000				
4-5	RD-AS45				11.7	6.4 - 7.9			1000	10 000				
4-6	RD-AS46				13.3	7.9 - 9.5			1000	10 000				
4-8	RD-AS48				16.5	9.5 - 12.7			1000	10 000				
4-10	RD-AS410				19.7	12.7 - 15.9			1000	10 000				
4-12	RD-AS412				22.9	15.9 - 19.1			500	5 000				
5-2	RD-AS52				4.1mm (#20)	4.0mm (5/32)			7.6	0.5 - 3.2	850	1020	1000	10 000
5-3	RD-AS53								9.2	3.2 - 4.8			1000	10 000
5-4	RD-AS54*								10.8	4.8 - 6.4			1000	10 000
5-4		RD-ASL54	10.8	4.8 - 6.4			500	5 000						
5-5	RD-AS55		12.1	6.4 - 7.9			500	5 000						
5-6	RD-AS56		14.0	7.9 - 9.5			500	5 000						
5-8	RD-AS58		17.1	9.5 - 12.7			500	5 000						
5-10	RD-AS510		20.3	12.7 - 15.9			500	5 000						
6-2	RD-AS62		4.9mm (#11)	4.8mm (3/16)			8.3	0.5 - 3.2	1160	1430			500	5 000
6-3	RD-AS63						9.8	3.2 - 4.8					500	5 000
6-4	RD-AS64				11.4	4.8 - 6.4	500	5 000						
6-4		RD-ASL64			11.4	4.8 - 6.4	250	2 500						
6-5	RD-AS65				12.9	6.4 - 7.9	500	5 000						
6-6	RD-AS66				14.6	7.9 - 9.5	500	5 000						
6-6		RD-ASL66			14.6	7.9 - 9.5	250	2 500						
6-8	RD-AS68				17.8	9.5 - 12.7	500	5 000						
6-8		RD-ASL68			17.8	9.5 - 12.7	250	2 500						
6-10	RD-AS610	RD-ASL610			21.0	12.7 - 15.9	250	2 500						
6-12	RD-AS612				24.1	15.9 - 19.1	250	2 500						

*ICCONS PAINTED RANGE IS AVAILABLE IN "RD-AS43", "RD-AS54" & "RD-AA43" RIVETS

(other colours and sizes available upon request).



RIVETS



RIVETS

Aluminium / Steel - Countersunk



Body - Aluminium

Mandrel - Steel



AS COUNTERSUNK



RIVET	Part No.	Drill	Body Dia	Length (mm)	Grip Range	Shear (N)	Tensile (N)	qty	qty
4-2	RC-AS42	3.3mm (#30)	3.2mm (1/8)	7.0	1.6 - 3.2	530	670	1000	10 000
4-3	RC-AS43			8.6	3.2 - 4.8			1000	10 000
4-4	RC-AS44			10.2	4.8 - 6.4			1000	10 000
4-5	RC-AS45			11.7	6.4 - 7.9			1000	10 000
4-6	RC-AS46			13.3	7.9 - 9.5			1000	10 000
5-2	RC-AS52	4.1mm (#20)	4.0mm (5/32)	7.6	0.5 - 3.2	850	1020	1000	10 000
5-3	RC-AS53			9.2	3.2 - 4.8			1000	10 000
5-4	RC-AS54			10.8	4.8 - 6.4			1000	10 000
5-6	RC-AS56			14.0	7.9 - 9.5			500	5 000
6-2	RC-AS62	4.9mm (#11)	4.8mm (3/16)	8.3	0.5 - 3.2	1160	1430	500	5 000
6-3	RC-AS63			9.8	3.2 - 4.8			500	5 000
6-4	RC-AS64			11.4	4.8 - 6.4			500	5 000
6-6	RC-AS66			14.6	7.9 - 9.5			500	5 000
6-8	RC-AS68			17.8	9.5 - 12.7			500	5 000
6-10	RC-AS610	21.0	12.7 - 15.9	250	2 500				

AS Aluminium / Steel

Aluminium / Aluminium - Dome Head



Body - Aluminium

Mandrel - Aluminium



AA DOME HEAD



RIVET	Part No.	Hole (mm)	Body Dia (mm)	Length (mm)	Grip Range	Shear (N)	Tensile (N)	qty	qty
4-2	RD-AA42	3.3mm (#30)	3.2mm (1/8)	7.0	1.6 - 3.2	530	670	1000	10 000
4-3	RD-AA43*			8.6	3.2 - 4.8			1000	10 000
4-4	RD-AA44			10.2	4.8 - 6.4			1000	10 000
4-6	RD-AA46			13.3	7.9 - 9.5			1000	10 000
4-8	RD-AA48			16.5	9.5 - 12.7			1000	10 000
5-4	RD-AA54	4.1mm (#20)	4.0mm (5/32)	10.8	4.8 - 6.4	850	1020	1000	10 000
5-6	RD-AA56			14.0	6.4 - 9.5			500	5 000
6-4	RD-AA64	4.9mm (#11)	4.8mm (3/16)	11.4	4.8 - 6.4	1160	1430	500	5 000
6-6	RD-AA66			14.6	6.4 - 9.5			500	5 000
6-8	RD-AA68			17.8	9.5 - 12.7			500	5 000

AA Aluminium / Aluminium

RIVETS

Aluminium / Steel - Multi Grip

Body - Aluminium

Mandrel - Steel



ASMG Multi Grip

RIVET	Part No.	Drill	Body Dia	Length (mm)	Grip Range	Shear (N)	Tensile (N)	qty	qty
4-1/3	RD-ASMG41.3	3.3mm (#30)	3.2mm (1/8)	8.4	0.8 - 4.8	600	900	1,000	10,000
4-4/5	RD-ASMG44.5			11.5	4.0 - 7.9			1,000	10,000
5-1/4	RD-ASMG51.4	4.1mm (#20)	4.0mm (5/32)	9.9	1.2 - 6.4	950	1500	1,000	10,000
5-5/6	RD-ASMG55.6			13.1	4.0 - 9.5			500	5,000
6-1/4	RD-ASMG61.4	4.9mm (#11)	4.8mm (3/16)	10.7	1.6 - 6.4	1320	2000	500	5,000
6-4/7	RD-ASMG64.7			17.3	6.4 - 12.7			500	5,000
6-7/9	RD-ASMG67.9			18.6	11.1 - 13.7			500	5,000



RIVET	Part No.	Drill	Body Dia	Length (mm)	Grip Range	Newton	Newton	qty	qty
5-1/4	RD-ASMG51.4SM	4.1mm (#20)	4.0mm (5/32)	9.9	1.2 - 6.4	950	1500	1,000	10,000
5-5/6	RD-ASMG55.6SM			13.1	4.0 - 9.5			500	5,000

Aluminium / Steel - Sealed Rivet

Body - Aluminium

Mandrel - Phosphated Steel



TA Sealed Rivet

RIVET	Part No.	Drill	Body Dia	Length (mm)	Grip Range	Shear (N)	Tensile (N)	qty	qty
4-2	RD-TA42	3.3mm (#30)	3.2mm (1/8)	9.1	1.6 - 3.2	1070	1250	1,000	10,000
4-3	RD-TA43			10.7	3.2 - 4.8			1,000	10,000
4-4	RD-TA44			12.3	4.8 - 6.4			1,000	10,000
4-5	RD-TA45			13.9	6.4 - 7.9			1,000	10,000
4-6	RD-TA46			15.5	7.9 - 9.5			1,000	10,000
5-3	RD-TA53	4.1mm (#20)	4.0mm (5/32)	11.1	3.2 - 4.8	1560	2140	1,000	10,000
5-4	RD-TA54			12.7	4.8 - 6.4			500	5,000
5-6	RD-TA56			15.9	7.9 - 9.5			500	5,000
6-2	RD-TA62	4.9mm (#11)	4.8mm (3/16)	10.3	0.5 - 3.2	2230	3070	500	5,000
6-3	RD-TA63			11.9	3.2 - 4.8			500	5,000
6-4	RD-TA64			13.5	4.8 - 6.4			500	5,000
6-5	RD-TA65			15.1	6.4 - 7.9			500	5,000
6-6	RD-TA66			16.7	7.9 - 9.5			500	5,000
6-8	RD-TA68			19.8	9.5 - 12.7			250	2,500
6-10	RD-TA610			23.0	12.7 - 15.9			250	2,500

ASMG Multi Grip

TA Sealed Rivet

RIVETS



RIVETS

Steel / Steel - Dome Head



Body - Steel (zinc plated)

Mandrel - Steel (zinc plated)



SS DOME HEAD



RIVET	Part No.	Drill	Body Dia	Length (mm)	Grip Range	SHEAR (N)	TENSILE (N)	qty	qty
4-2	RD-SS42	3.3mm (#30)	3.2mm (1/8)	7.0	1.6 - 3.2	1160	1380	1000	10 000
4-3	RD-SS43			8.6	3.2 - 4.8			1000	10 000
4-4	RD-SS44			10.2	4.8 - 6.4			1000	10 000
4-6	RD-SS46			13.3	7.9 - 9.5			1000	10 000
5-3	RD-SS53	4.1mm (#20)	4.0mm (5/32)	9.2	3.2 - 4.8	1650	2100	1000	10 000
5-4	RD-SS54			10.8	4.8 - 6.4			1000	10 000
5-6	RD-SS56			14.0	6.4 - 9.5			500	5 000
6-2	RD-SS62	4.9mm (#11)	4.8mm (3/16)	8.3	0.5 - 3.2	2400	3030	500	5 000
6-3	RD-SS63			9.8	3.2 - 4.8			500	5 000
6-4	RD-SS64			11.4	4.8 - 6.4			500	5 000
6-6	RD-SS66			14.6	6.4 - 9.5			500	5 000
6-8	RD-SS68			17.8	9.5 - 12.7			500	5 000
8-4	RD-SS84*	6.5mm	6.4mm (1/4)	12.7	3.2 - 6.4	4450	5520	250	2 500
8-6	RD-SS86*			15.9	6.4 - 9.5			250	2 500

* Bonus panel bits not included with the 8 series size

SS Steel / Steel

Stainless / Stainless - Dome Head



Body - 304 Stainless Steel

Mandrel - 304 Stainless Steel



STST DOME HEAD



RIVET	Part No.	Drill	Body Dia	Length (mm)	Grip Range	SHEAR (N)	TENSILE (N)	qty	qty
4-2	RD-STST42	3.3mm (#30)	3.2mm (1/8)	7.0	1.6 - 3.2	1870	2360	1000	10 000
4-3	RD-STST43			8.6	3.2 - 4.8			1000	10 000
4-4	RD-STST44			10.2	4.8 - 6.4			1000	10 000
4-6	RD-STST46			13.3	7.9 - 9.5			1000	10 000
5-2	RD-STST52	4.1mm (#20)	4.0mm (5/32)	9.2	3.2 - 4.8	2900	3650	1000	10 000
5-4	RD-STST54			10.8	4.8 - 6.4			1000	10 000
5-6	RD-STST56			14.0	6.4 - 9.5			500	5 000
6-2	RD-STST62	4.9mm (#11)	4.8mm (3/16)	8.3	0.5 - 3.2	4230	5340	500	5 000
6-4	RD-STST64			11.4	4.8 - 6.4			500	5 000
6-6	RD-STST66			14.6	6.4 - 9.5			500	5 000
6-8	RD-STST68			17.8	9.5 - 12.7			500	5 000

STST Stainless / Stainless

RIVETS



RT-18VE5 CORDLESS RIVET TOOL



18v Cordless Blind Rivet Tool

NEW

- 2 x 2.0 Ah Lithium Ion Batteries
- Mandrel collector
- Battery level indicator
- 3 x L.E.D lights to light up work surface
- Soft Grip for comfort
- Belt clip suit both left and right handed operators
- 1 Year Warranty



Part No.	Description	Suits Body Dia	qty
RT-18VE5	18v Cordless Professional blind rivet tool Kit includes: Robust carry case, 2 x 2.0Ah batteries, Li-Ion charger, 1x spare Jaw set 4 x different size tips.	2.4 to 4.8 (3/32 to 3/16) in Aluminium, Steel & Stainless Steel	1

Rivet Body Material	RT-18VE5 Rivet Tool Capacity			
	Ø 2.4mm Ø 3/32"	Ø 3.2mm Ø 1/8"	Ø 4.0mm Ø 5/32"	Ø 4.8 Ø 3/16"
■ Aluminium	✓	✓	✓	✓
■ Steel	✓	✓	✓	✓
■ Stainless Steel	✓	✓	✓	✓



FEATURES

- ERGONOMIC SOFT COMFORT GRIP DESIGN**
- REMOVABLE MANDREL COLLECTOR**
Easy twist on twist of design
- POWERFUL PERFORMANCE**
Powerful 18v suitable for rivets up to 4.8SS
- 3 X L.E.D LIGHTS TO LIGHT UP WORK SURFACE**
- 4 X DIFFERENT SIZE TIPS.**
for all rivets up to 4.8mm
- 1X SPARE JAW SET**
- 2 X 2.0 AH LITHIUM ION RECHARGEABLE BATTERIES**
- BATTERY LEVEL INDICATOR**
- Stroke - 21mm**
- Cycle Time <2.0 seconds**





RTP-55

Professional Blind Rivet Tool

High Quality Professional Tool Made in Taiwan

NEW



Part No.	Description	Suits Body Dia	qty	qty
RTP-55	Heavy Duty Professional blind rivet tool	2.4 to 4.8 (3/32 to 3/16)	1	30

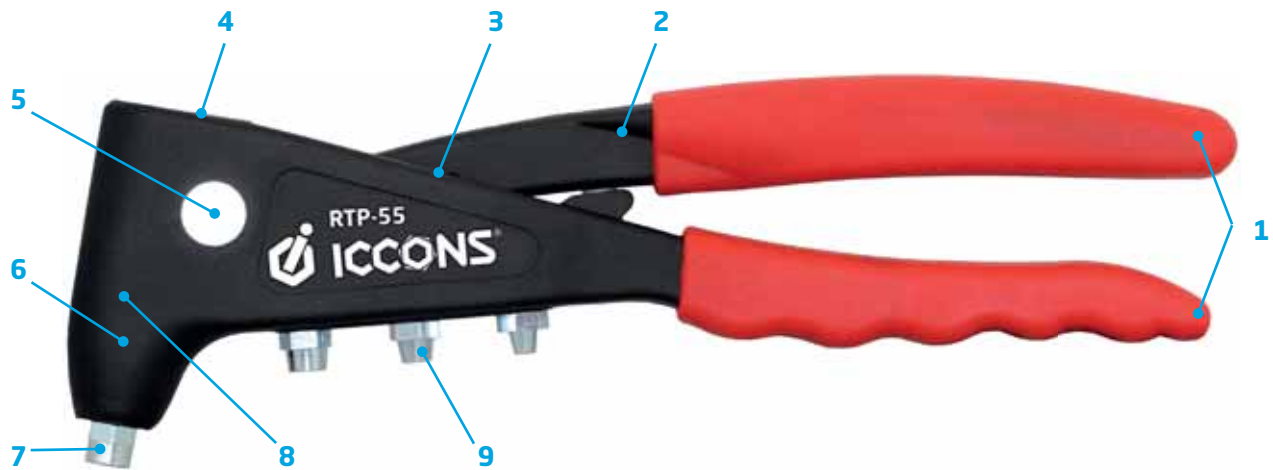

FEATURES

- 1 "ONE HAND" GRIP DESIGN**
- 2 STURDY FORGED STEEL HANDLE**
Avoids bending or breaking
- 3 POWERFUL PERFORMANCE**
Handle design reduces effort required by the installer
- 4 SIMPLE DESIGN FOR EASY MAINTENANCE & JAW REPLACEMENT**
- 5 ANTI ROTATION FULCRUM PIN**
Eliminates excess wearing of the tool body
- 6 ALUMINIUM BODY WITH ALL STEEL JAW HOUSING**
For increased durability

- 7 SPRING DESIGN HOLDS RIVET IN ANY POSITION**
Prevents the rivet falling out
- 8 HIGH QUALITY JAWS AND COLLET CASE FOR LONGER OPERATION LIFE**
- 9 4 INTERCHANGEABLE NOSE PIECES**
Sets blind rivets from 2.4 to 4.8 (3/32 to 3/16)

Rivet Body Material	RTP-55 Rivet Tool Capacity			
	Ø 2.4mm Ø 3/32"	Ø 3.2mm Ø 1/8"	Ø 4.0mm Ø 5/32"	Ø 4.8 Ø 3/16"
■ Aluminium	✓	✓	✓	✓
■ Steel	✓	✓	✓	
■ Stainless Steel	✓	✓	✓	



Follow Us



Facebook
ICCONS Pty Ltd



Instagram
iccons.pty.ltd



LinkedIn
ICCONS Pty Ltd



ONLY THROUGH ICCONS

M-TCH7390K Collated Driver Tool

Durable housing made from glass filled reinforced nylon
Lightweight collated driver tool
Quick change double ended drive bits
30 screws per strip - no pre-drilling
No more dropped screws - no more lost screws
SCREW GAUGE RANGE: 8g / 10g screws
SCREW LENGTH RANGE: 38mm to 75mm



M-TCH7392SFK Driver Tool Attachment

Durable housing made from glass filled reinforced nylon Lightweight driver tool attachment
Quick change double ended drive bits
30 screws per strip - no pre-drilling
No more dropped screws - no more lost screws
SCREW GAUGE RANGE: 8g / 10g screws
SCREW LENGTH RANGE: 25mm to 50mm



M-TFDVL41 Coil Auto Feed Tool

With extension handle the M-TFDVL41 ergonomic works while standing up!
Adjustable, accurate depth control for countersunk
holds up to 150 screws per coil
Durable and rugged design
Drives up to 75mm screws
No more dropped screws - no more lost screws
SCREW GAUGE RANGE: 8g / 10g screws
SCREW LENGTH UP TO: 75mm screws

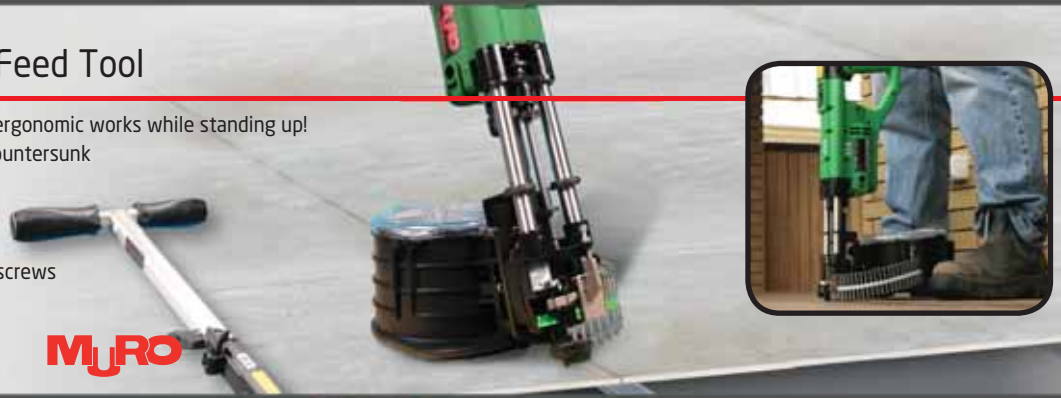

M-TFLVL41 Coil Auto Feed Tool

With extension handle the M-TFLVL41 ergonomic works standing up!
Durable and rugged design and construction
Adjustable, accurate depth control for countersunk
holds up to 150 screws per coil
No special tool required to change double ended drive bits.
SCREW GAUGE RANGE: 12g / 14g screws
SCREW LENGTH RANGE: 50mm to 100mm



M-TCH7241A Villaboard and Compressed Sheet Tool

30 screws per easy load strip, no more dropping screws
Adjustable depth control for consistent countersinking
Double ended bits - easily changes without tools
Rubber tipped nose to protect the work surface
Positive depth adjustment
SCREW GAUGE RANGE: 7g screws
FOR USE IN VILLABOARD®



9mm VILLA

MURO



MURO AUTO FEED - COLLATED SCREWS

Screw range for M-TCH7390K:

ZINC

IC3

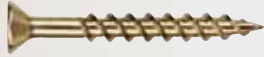

Strip Chipboard Screws | 8 & 10 Gauge | Zinc Yellow | Category 3



IC3



Strip Self Drilling Wing Screw | 8 & 10 Gauge | Category 3

Shield Guard



Strip Type 17 Deck Screw | 8 Gauge | Shield Guard™ Category 3 | for treated pine

IC3



Strip Type 17 Compressed Sheet Screw | 8 Gauge | Category 3

305 SS

IC3

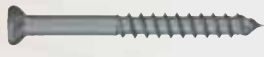

Strip Ejector Decking Screw | 10 Gauge | Category 3 | 305 Stainless Steel

Page 110

Screw range for M-TCH7392SFK:

ZINC

IC3



Strip Chipboard Screws | 8 & 10 Gauge | Zinc Yellow | Category 3



IC3



Strip Self Drilling Wing Screw | 8 & 10 Gauge | Category 3

Shield Guard



Strip Type 17 Deck Screw | 8 Gauge | Shield Guard™ Category 3 | for treated pine

IC3



Strip Type 17 Compressed Sheet Screw | 8 Gauge | Category 3

305 SS

IC3



Strip Ejector Decking Screw | 10 Gauge | Category 3 | 305 Stainless Steel

Page 112

Screw range for M-TFDVL41:

ZINC

IC3



Coil Chipboard Screws | 8 & 10 Gauge | Zinc Yellow | Category 3

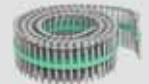

IC3



Coil Self Drilling Wing Screw | 8 & 10 Gauge | Category 3

Shield Guard



Coil Type 17 Deck Screw | 8 Gauge | Shield Guard™ Category 3 | for treated pine

IC3



Coil Type 17 Compressed Sheet Screw | 8 Gauge | Category 3

305 SS

IC3



Coil Ejector Decking Screw | 10 Gauge | Category 3 | 305 Stainless Steel

Page 116

Screw range for M-TFLVL41:

Shield Guard

IC3



Coil Self-Drilling Wing | 10 & 14 Gauge | Category 3

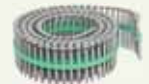

305 SS

IC3



Coil Ejector Decking Screw | 14 Gauge

Page 118

Screw range for M-TCH7241A:

ZINC



Needle Point | 7 Gauge reduced head for fibre cement sheeting | Zinc Yellow



IC3



Needle Point | 7 Gauge reduced head for fibre cement sheeting | Category 3

Page 114



MURO

M-TCH7390K Collated Driver Tool

**ONLY
THROUGH
ICCONS**

No pre-drilling

Quick change double ended drive bits

Durable housing made from glass filled reinforced nylon

30 screws per strip

No more dropped screws

No more lost screws

Lightweight

The M-TCH7390 is a tough and durable collated driver tool attachment that professional contractors prefer. The M-TCH7390 is a general purpose attachment for commercial flooring, fencing and decking fastening solutions and features a rubber nose piece to prevent damage to the work surface. With the flexibility to use with or without the extension handle this attachment is the ideal choice for your collated screw fastening applications.

SYSTEM FEATURES

- Ergonomic design
- Tight space access
- Long-life nickel plated screw guides
- Kit bag available includes tool, T-handle, pouch & adaptor
- Rubber nose piece prevents work surface damage
- Work standing up when fitted with extension handle
- Adjustable, accurate depth control for countersinking
- Low user vibration with adjustable, comfortable T handle configuration

SYSTEM APPLICATIONS

- Sub floor and commercial flooring
- Decking
- Second storey floor fixing
- Mobile home and caravan construction

M-TCH7390K

Gauge range: 8g / 10g screws

Length range: 38 to 75mm



Part No.	Description	qty
M-TCH7390K	CH7390 Kit - complete kit includes Ch7390 unit screw pouch, ext handle & carry bag	1
M-CH7390 HANDLE	CH7390 Handle	1
M-DSQR28118	Drive Bit No.2 square for CH7390 - double ended	1
M-DTX258118	Drive Bit Torx 25 for CH7390 / CH7392SF - double ended	1
M-A170-70060	Tool Adapter to suit Milwaukee 6702-20	1
M-A170-70120	Tool Adapter to suit Hitachi W6VB2 / W8VB3	1
M-A170-70130	Tool Adapter to suit Makita FS2300 / FS2500	1
M-A170-70140	Tool Adapter to suit Bosch GSR6-25TE	1
M-ATTDECK	Deck attachment for CH7390 tool - 3- 25mm gap adjustment	1

MURO



MURO Chipboard Screws

■ Strip - 8 & 10 Gauge - Zinc Yellow ■ Strip - 8 Gauge - Category 3

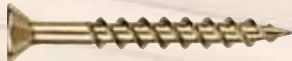

ZINC

INTERNAL

IC3

EXTERNAL



IC Find #	Part No.	IC Find #	Part No.	Description	mm	mm	mm	qty
M-102	M-CB08038ZY (CS8112YMSU)			8 x 38mm - Strip	CSK	No.2 Sq	18	1000
M-104	M-CB08045ZY (CS8134YMSU)			8 x 45mm - Strip	CSK	No.2 Sq	18	1000
M-106	M-CB08050ZY (CS8200YMSU)	M-116	M-CB08050C3 (CS8200GMSU)	8 x 50mm - Strip	CSK	No.2 Sq	18	1000
M-108	M-CB08065ZY (CS8212YMSU)			8 x 65mm - Strip	CSK	No.2 Sq	18	1000
M-110	M-CB08075ZY (CS8300YMSU)			8 x 75mm - Strip	CSK	No.2 Sq	18	1000
M-112	M-CB10050ZY (CS0200YMSU)			10 x 50mm - Strip	CSK	No.2 Sq	18	1000



MURO Self Drilling Wing Screw

■ Strip - 8 Gauge - Category 3

IC3

EXTERNAL



IC Find#	Part No.	Description	mm	Drive	mm	qty
M-138	M-SDW08042C3 (RS8158GMSU)	8 x 42mm - Strip	CSK	No.2 Sq	1-3	1000

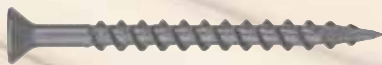

MURO Type 17 Deck Screw

■ Strip - 8 Gauge - Category 3 (Shield Guard), suits treated pine

SHIELD
GUARD

EXTERNAL



IC Find#	Part No.	Description	mm	Drive	mm	qty
M-120	M-DS08050C (ES8200CMSU-GY)	8 x 50mm - Strip	CSK	No.2 Sq	25	1000
M-122	M-DS08065C (ES8212CMSU-GY)	8 x 65mm - Strip	CSK	No.2 Sq	25	1000



MURO Type17 Compressed Sheet

■ Strip - 8 Gauge - Category 3

IC3

EXTERNAL



IC Find#	Part No.	Description	mm	Drive	mm	qty
M-124	M-CS08045C3 (ABS8134GMSU)	8 x 45mm - Strip	CSK	No.2 Sq	25	1000



MURO Ejector Decking Screw

IC3

EXTERNAL

305
SS

EXTERNAL



IC Find #	Part No.	IC Find #	Part No.	Description	mm	mm	mm	qty
M-126	M-EJ10050C3 (TX0200CMSU-EJ)			10 x 50mm - Strip	CSK	Torx	25	1000
		M-128	M-EJ10050SS (TX0200SMSU-EJ)	10 x 50mm - Strip	CSK	Torx	25	1000
		M-130	M-EJ10065SS (TX0212SMSU-EJ)	10 x 65mm - Strip	CSK	Torx	25	1000



MURO AUTO FEED - COLLATED SCREWS



**ONLY
THROUGH
ICCONS**

MURO

M-TCH7392SFK Driver Tool Attachment

A tough, durable collated driver for the professional contractors. The M-TCH7392SFK is a short stroke fast general purpose commercial fencing and flooring system featuring non slip nose piece suitable for high volume production projects

SYSTEM FEATURES

- Long-life nickel plated screw guides
- Housing can be easily rotated for access into tight spaces
- Ergonomic design
- Work standing up when fitted with extension handle
- Non slip nose piece (please note may mark surfaces, please acknowledge this if fastening decking etc)
- Adjustable, accurate depth control for countersinking

SYSTEM APPLICATIONS

- Sub floor and commercial flooring
- Fencing
- Decking
- Truck and trailer construction and repairs
- Mobile home and caravan construction

Quick change double ended drive bits

Durable housing made from glass filled reinforced nylon

30 screws per strip

No pre-drilling

No more dropped screws

No more lost screws

Lightweight

M-TCH739SFK

Gauge range: 8g / 10g screws

Length range: 25 to 50mm



Part No.	Description	qty
M-TCH7392SFK	CH7392SF Kit - complete kit includes CH7392SF unit, screw pouch, extension handle & carry bag	1
M-TCH7392SF	CH7392SF - unit only	1
M-DSQR28118	Drive Bit No.2 square for CH7392SF - double ended	1
M-DTX258118	Drive Bit Torx 25 for CH7390 / CH7392SF - double ended	1
M-A170-70060	Tool Adapter to suit Milwaukee 6702-20	1
M-A170-70120	Tool Adapter to suit Hitachi W6VB2 / W8VB3	1
M-A170-70130	Tool Adapter to suit Makita FS2300 / FS2500	1
M-A170-70140	Tool Adapter to suit Bosch GSR6-25TE	1



MURO Chipboard Screws

■ Strip - 8 & 10 Gauge - Zinc Yellow ■ Strip - 8 Gauge - Category 3



ZINC INTERNAL



IC3 EXTERNAL



IC Find #	Part No.	IC Find #	Part No.	Description	mm	mm	mm	qty
M-102	M-CB08038ZY (CSB112YMSU)			8 x 38mm - Strip	CSK	No.2 Sq	18	1000
M-104	M-CB08045ZY (CSB134YMSU)			8 x 45mm - Strip	CSK	No.2 Sq	18	1000
M-106	M-CB08050ZY (CSB200YMSU)	M-116	M-CB08050C3 (CSB200GMSU)	8 x 50mm - Strip	CSK	No.2 Sq	18	1000
M-112	M-CB10050ZY (CSO200YMSU)			10 x 50mm - Strip	CSK	No.2 Sq	18	1000

MURO Self Drilling Wing Screw

■ Strip - 8 Gauge - Category 3



IC3 EXTERNAL



IC Find#	Part No.	Description	mm	Drive	mm	qty
M-136	M-SDW08032C3 (RSB158GMSU)	8 x 32mm - Strip	CSK	No.2 Sq	1-3	1000
M-138	M-SDW08042C3 (RSB158GMSU)	8 x 42mm - Strip	CSK	No.2 Sq	1-3	1000
M-140	M-SDW10042C3 (RSO158GMSU)	10 x 42mm - Strip	CSK	No.2 Sq	1.2 - 3	1000
M-141	M-SDW10050C3 (RSO200GMSU)	10 x 50mm - Strip	CSK	No.2 Sq	1.2 - 3	1000

MURO Type 17 Deck Screw

■ Strip - 8 Gauge - Category 3 (Shield Guard), suits treated pine



SHIELD GUARD EXTERNAL

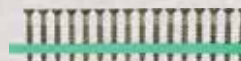

IC Find#	Part No.	Description	mm	Drive	mm	qty
M-120	M-DS08050C (ESB200CMSU-GY)	8 x 50mm - Strip	CSK	No.2 Sq	25	1000

MURO Type17 Compressed Sheet

■ Strip - 8 Gauge - Category 3



IC3 EXTERNAL

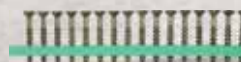

IC Find#	Part No.	Description	mm	Drive	mm	qty
M-124	M-CS08045C3 (ABS8134GMSU)	8 x 45mm - Strip	CSK	No.2 Sq	25	1000

MURO Ejector Decking Screw



IC3 EXTERNAL

305 SS EXTERNAL



IC Find #	Part No.	IC Find #	Part No.	Description	mm	mm	mm	qty
M-126	M-EJ10050C3 (TX0200CMSU-EJ)			10 x 50mm - Strip	CSK	Torx	25	1000
		M-128	M-EJ10050SS (TX0200SSMSU-EJ)	10 x 50mm - Strip	CSK	Torx	25	1000



MURO AUTO FEED - COLLATED SCREWS



Features & Benefits:

- 30 screws per easy load strip, no more dropped screws
- Adjustable depth control for consistent countersinking
- Double ended bits - easily changes without tools
- Rubber tipped nose to protect the work surface

Part No.	Description	qty
M-TCH7241A	CH7241A unit only	1
M-DSQR25118	Drive Bit Square for CH7241A - double ended	1
M-A170-70060	Tool Adapter to suit Milwaukee 6702-20	1
M-A170-70120	Tool Adapter to suit Hitachi W6VB2 / W8VB3	1
M-A170-70130	Tool Adapter to suit Makita FS2300 / FS2500	1
M-A170-70140	Tool Adapter to suit Bosch GSR6-25TE	1

MURO Reduced head for fibre cement sheeting



■ Strip - 7 Gauge needle point - Zinc Yellow

■ Strip - 7 Gauge needle point - Category 3

ZINC INTERNAL

IC3 EXTERNAL



IC Find #	Part No.	IC Find #	Part No.	Description	mm	mm	mm	qty
M-132	M-NP07032ZY (YS7114YMS)	M-134	M-NP07032C3 (YS7114GMS)	7 x 32mm Reduced head - Strip	CSK	No.2 Sq	25	1000





M-TCH7241A

Gauge range: 7g

Needle Point screws for Villaboard®

**ONLY
THROUGH
ICCONS**

MURO

30 screws per
easy load
strip, no more
dropping screws

Adjustable
depth control
for consistent
countersinking

Double ended
bits - easily
changes
without tools

Rubber tipped
nose to protect
the work surface



**9mm
VILLA**

Positive
Depth
Adjustment



M-TFDVL41

Gauge range: 8g / 10g screws

Length range: 38 to 75mm



Part No.	Description	qty
M-TFDVL41	Coil Auto Feed Tool with adjustable handle	1
M-DSQR27114	Drive Bit No.2 square for FDVL41 - double ended	1
M-DTX257114	Drive Bit Torx 25 for FDVL41 - double ended	1
MC-ATTDECK	Deck attachment for FDVL41 / FLVL41 coil tool - 3- 25mm gap adjustment	1

The M-TFDVL41 stands alone with capability to take on any jobs providing versatility that meets all construction fastening requirements. Attach the extension handle and the M-TFLVL41 is an ergonomic worker for stand up operation! The contractors choice!

SYSTEM FEATURES

- Reversible
- No more dropping screws.
- No more losing screws.
- Ergonomic design
- Stand-up operation
- Low user vibration with adjustable, comfortable T handle configuration

SYSTEM APPLICATIONS

- Commercial flooring
- Decking
- Sub Floor
- Dock systems
- Truck construction
- Trailer construction and repairs
- Roofing systems
- Caravan construction
- Mobile homes manufacture

With the extension handle the M-TFDVL41 ergonomic works while standing up!

Durable and rugged design

Drives up to 75mm screws

Adjustable, accurate depth control for countersunk

Holds up to 150 screws per coil

Screw gauge range: 12g / 14g

No special tool required to change double ended drive bits.





MURO Chipboard Screws

■ Coil - 8 & 10 Gauge - Zinc Yellow ■ Coil - 8 Gauge - Category 3



ZINC INTERNAL



IC3 EXTERNAL



IC Find #	Part No.	IC Find #	Part No.	Description	mm	mm	mm	qty
M-202	MC-CB08038ZY (CSB112Y)			8 x 38mm - Coil	CSK	No.2 Sq	18	2700
M-204	MC-CB08045ZY (CSB134YLP)			8 x 45mm - Coil	CSK	No.2 Sq	18	2700
M-206	MC-CB08050ZY (CSB200YLP)	M-216	MC-CB08050C3 (CSB200GLP)	8 x 50mm - Coil	CSK	No.2 Sq	18	1800
M-212	MC-CB10050ZY (CSO200YLP)			10 x 50mm - Coil	CSK	No.2 Sq	18	1800



IC3 EXTERNAL

MURO Self Drilling Wing Screw

■ Coil - 8 Gauge - Category 3

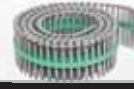

IC Find#	Part No.	Description	mm	Drive	mm	qty
M-238	MC-SDW08042C3 (RSB158G)	8 x 42mm - Coil	CSK	No.2 Sq	1-3	2700
M-240	MC-SDW10042C3 (RSO158G)	10 x 42mm - Coil	CSK	No.2 Sq	1.2 - 3	2700
M-242	MC-SDW10055C3 (RSO214GLP)	10 x 55mm - Coil	CSK	No.2 Sq	1.2 - 3	1800



SHIELD GUARD EXTERNAL

MURO Type 17 Deck Screw

■ Coil - 8 Gauge - Category 3 (Shield Guard), suits treated pine

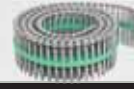

IC Find#	Part No.	Description	mm	Drive	mm	qty
M-220	MC-DS08050C (ESB200WLP-G)	8 x 50mm - Coil	CSK	No.2 Sq	25	1800
M-222	MC-DS08065C (ESB212WLP-GY)	8 x 65mm - Coil	CSK	No.2 Sq	25	1800



IC3 EXTERNAL

MURO Type17 Compressed Sheet

■ Coil - 8 Gauge - Category 3

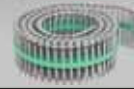

IC Find#	Part No.	Description	mm	Drive	mm	qty
M-224	M-CS08045C3 (ABS8134GMSU)	8 x 45mm - Coil	CSK	No.2 Sq	25	2700



IC3 EXTERNAL

305 SS EXTERNAL

MURO Ejector Decking Screw



IC Find #	Part No.	IC Find #	Part No.	Description	mm	mm	mm	qty
M-226	MC-EJ10050C3 (TX0200CLP-EJ)			10 x 50mm - Coil	CSK	Torx	25	1800
		M-228	MC-EJ10050SS (TX0200SLP-EJ)	10 x 50mm - Coil	CSK	Torx	25	900
		M-230	MC-EJ10065SS (TX0212SLP-EJ)	10 x 65mm - Coil	CSK	Torx	25	1000



M-TFLVL41



MURO

M-TFLVL41

Coil Auto Feed Tool

The M-TFLVL41 is a one step process - no pre drilling required. Depending on screw size this easy load tool holds between 100 and 150 screws.

The M-FLVL41 coil feed system has adjustable depth control systematic countersinking - no raised heads. Attach the extension handle and the M-TFLVL41 is an ergonomic worker for stand up operation!

The M-TFLVL41 operates in a large range of applications from truck and trailer bodies, landscaping timber paths to commercial flooring and much more. The M-TFLVL41 provides amazing labour savings on the job!

SYSTEM FEATURES

- Reversible
- No more dropping screws
- No more losing screws
- Ergonomic design
- Work standing up when fitted with extension handle
- Low user vibration with adjustable, comfortable T handle configuration

SYSTEM APPLICATIONS

- Timber to Mild Steel
- Timber to Timber
- Timber to Aluminium
- Board walks
- Truck & Trailer Restoration
- Mobile homes and caravan construction



Gauge range: 12g / 14g screws

Length range: 30 to 100mm

With the extension handle the M-TFLVL41 ergonomic works while standing up!

Durable and rugged design and construction

Drives from 50mm up to 100mm screws

Adjustable, accurate depth control for countersunk

holds up to 150 screws per coil

Screw gauge range: 12g / 14g

No special tool required to change double ended drive bits.



MURO Coil Auto Feed Tool



Part No.	Description	qty
M-TFLVL41	Coil Auto Feed Tool with adjustable handle	1
M-DSQR38000	Drive bit No.3 square for FLVL41 - double ended	1
MC-ATTDECK	Deck attachment for FDVL41 / FLVL41 coil tool - 3- 25mm gap adjustment	1

MURO Self-Drilling Wing



■ Coil - 10, 14 Gauge - Category 3

IC3	EXTERNAL	SHIELD GUARD	EXTERNAL					
IC Find#	Part No.	IC Find#	Part No.	Description	mm	Drive	mm	qty
M-278	MC-SDW10030C3 (RSM430GFL)			10 x 30mm - Coil	CSK	No.3 Sq	1.5 - 5	2400
		M279	MC-SDW14045C3 (RSM645MFL)	14 x 45mm - Coil	CSK	No.3 Sq	4 - 8	1800
		M-280	MC-SDW14055C3 (RSM655WFL-GY)	14 x 55mm - Coil	CSK	No.3 Sq	4 - 8	1200
		M-282	MC-SDW14075C3 (RSM675WFL-GY)	14 x 75mm - Coil	CSK	No.3 Sq	4 - 8	600

MURO Ejector Decking Screw

■ Coil - 14 Gauge - Category 3 ■ Coil - 14 Gauge - Stainless Steel Material Grade 305



IC3	EXTERNAL	305 SS	EXTERNAL					
IC Find #	Part No.	IC Find #	Part No.	Description	mm	mm	mm	qty
M-274	MC-EJ14075C3 (TS4300CFL-EJ)	M-284	MC-EJ14075SS (TS4300SFL-EJ)	14 x 75mm - Coil	CSK	No.3 Sq	25	660
M-276	MC-EJ14100C3 (TS4400CFL-EJ)	M-286	MC-EJ14100SS (TS4400SFL-EJ)	14 x 100mm - Coil	CSK	No.3 Sq	25	660





SCREW WARRANTY

NAUTILUS®
XTEND 4

NAUTILUS®
XTEND 5

WARRANTY

ICCONS® Nautilus® Self - Drilling Screws

ICCONS® is proud to offer a range of high quality, corrosion resistant Self-Drilling Screws for the Australian marketplace. ICCONS® guarantees the Structural Integrity of its Nautilus® Self-Drilling Screws which includes the head and shank area against the effects of corrosion or other metallurgical manufacturing defects.

ICCONS® references International Standard ISO 9223:2012(E) as guidance for establishing the screw warranty periods and conditions referenced below.

Atmospheric conditions, pollution levels, chemicals, humidity and wetness all have a large impact on the expected serviceable life of the screws. ISO9223:2012(E) provides guidelines to assist in determining the severity of the corrosive environment that the ICCONS® Nautilus® screws will be exposed to.

ICCONS® follows ISO 9223:2012 (E) Categories C2 to CX and will warrant the structural integrity of the screw and washer system for the period indicated in each category. It should be noted the ICCONS® Warranty covers the structural integrity and performance of the entire screw (head and threaded shank area) and does not include the aesthetic appearance of the coating.

Corrosivity Category - ISO 9223:2012(E) Annex C

	C2 Low	C3 Medium	C4 High	C5 Very High	CX Extreme
Exposure Type	Temperate Low Pollution Short Term Wet	Temperate Mild Pollution Low Industrial	Temperate Mild Pollution Low Marine Mild Industrial	Subtropical High Pollution Mild Marine Severe Industrial	Tropical Climate Extreme Pollution Severe Marine Extreme Industrial
Location Guidance	20km from Ocean	3km from Ocean	1-3km from Ocean	150m from Ocean	Breaking Surf
ICCONS® Screw Recommendation	IC4	IC4	IC4	IC4	Nautilus® XTEND™ 5
Coating	Warranty Period (years)				
NAUTILUS® XTEND 5 (IC5)	40	30	25	15	On Inspection
NAUTILUS® XTEND 4 (IC4)	30	20	15	10	On inspection
NAUTILUS® 4 (IC4)	30	20	15	10	On Inspection
NAUTILUS® 3 (IC)	25	15	7	NR	NR
3DG (Nautilus) (FRIULSIDER COATING)	15	7.5	NR	NR	NR

NR = Not Recommended Nautilus® XTEND™ 5 - Available on request.

Australian Standard AS/NZS 2312-2002 states that it is "very difficult if not impossible, to predict accurately the aggressiveness of a given environment and a certain amount of educated judgement is required to assess its Category, an inspection of the local environment, the building type and the condition of similar structures in the area is usually necessary.

Screw selection should always be suitable for both the application intended and be fully compatible for use with the other materials in the build. ICCONS® Nautilus® screws are suitable for use with Bluescope® Zinalume®, ColorBond® and UltraSteel® cladding and roofing profiles.

The table above is meant as a guide only to aid in the selection of appropriate screw material / coating for the application and conditions of the intended use. Always check with recommendations from relevant roll formers for material compatibility, if unsure seek professional advice.



ICCONS® WARRANTY is subject to the following conditions and limitations:

- ICCONS® Screws not exposed to rain are required to be washed down every 6 months.
- ICCONS® screws must be installed correctly by use of a screw gun.
- For applications in coastal regions or where there may be heavy industrial pollutants (chemical plants, airports), ICCONS® screws should be washed down every 3 months.
- Any warranty claim must be supported by full written details of the alleged defect, the date of installation, the application and build detail, location of the installation and proof of purchase.
- All ICCONS® roofing and cladding screws must be head marked IC4.

ICCONS® Warranty does not apply and ICCONS® will not be made liable for (to the extent permitted by law) any defect or fault arising from the following conditions:

- Damage caused by exposure to chemical agents, fumes, soils, ashes, fertilisers, liquids and solids other than natural rain fall.
- Incorrect screw selection for the application or the environment they are used in.
- Tempest, War or act of God.
- Incorrect screw selection for the compatibility with other materials used in the build.
- Over tightened incorrectly installed screws that fail due to stress fatigue.

ICCONS® will warrant any screws that are deemed to be defective after inspection of the specific project and consideration of the above criteria.

To the extent permitted by law, ICCONS® will not be liable for any loss or damage caused (including consequential or special loss or damage) whether by negligence or otherwise which may be suffered or incurred by any person or which may arise directly or indirectly in respect of the supply or use of the products or otherwise under or in connection with the warranty.

Our Goods come with guarantees that cannot be excluded under the Australian Consumer Law. You are entitled to a replacement for a major failure and for compensation for any other reasonably foreseeable loss or damage. You are also entitled to have any goods repaired or replaced if the goods fail to be acceptable quality and failure does not amount to a major failure.

It is recommended that an appropriate screw gun with depth gauge and clutch setting be used.

While the 'IC find' number makes selection easier, the part number is still helpful because it contains information about the screw i.e. type, gauge, length, coating etc. While a part number may seem more complex it need not be, so ICCONS® have devised this table to help understand the "ICFIND" numbering system.

Recommended Drill Speeds

Screw Type	RPM
Metal SDS	2500 rpm
Metal SDS - 5 Series	1800 rpm
Timber - Type 17	1500 rpm
Needle Point - Steel	2500 rpm
Needle Point - Timber	1000 rpm
Chipboard	1000 rpm

Example Part Number:

104W - SDHXC1016C4W

104	W	SD	HX	C	10	16	C4	W
IC FIND	IC FIND SUFFIX	SCREW GROUP	DRIVE/HEAD STYLE	THREAD TYPE	GAUGE	LENGTH (MM)	COATING / MATERIAL	SUFFIX
100 - 499	W Washer	SD SELF DRILLING	HX Hex Head	C Coarse	06	VARIOUS	ZY Zinc Yellow	W Washer
500 - 699		T17 TYPE 17	WA Wafer Head	F Fine	07		ZC Zinc Clear	X Cyclonix washer
700 - 899	X Cyclonix washer	NP NEEDLE POINT	BU Bugle Head	TG Top Grip	08		ZG Zinc Grey	
000 - 099		CB CHIPBOARD	FH Flathead	UNI Metal & Timber	10		C3 Category 3	
			CS Countersunk	5F #5 Series Fine	12		C4 Category 4	
			BH Button Head	WG Wing	14		SS Stainless Steel	
			PH Pan Head	SE Self Embedding				
			BB Bugle Baton					



stainless steel SDS bimetal screws

HIGH LEVEL CORROSION RESISTANT STAINLESS STEEL FUSED WITH HARDENED CARBON STEEL SELF-DRILLING TIPS

ICCONS® Bi-metal screws combine the high level corrosion resistance of 300 series stainless steel and the drilling performance of carbon steel self-drilling screws. Each Bi-metal screw has a hardened, self-drilling carbon steel drill point fused to the stainless steel shank. ICCONS® Bi-metal screws are the perfect choice for coastal & industrial applications or if your job is exposed to salt spray or chemicals.



Self Drilling Pan Head - Coarse

NEW

■ 8 Gauge - 304 (A2) Bi-Metal Stainless Steel



304 SS Bimetal EXTERNAL

IC Find #	Part No.	Description	mm	mm	Thread /mm	qty	qty
402	SDPH0816SS	8-18 x 16 NEW	PH2	1.5 -3.0	Full	1000	8000
403	SDPH0819SS	8-18 x 19 NEW	PH2	1.5 -3.0	Full	1000	8000
404	SDPH0825SS	8-18 x 25 NEW	PH2	1.5 -3.0	Full	1000	6000

* Also referenced on Page 137

Self Drilling Wafer Head

■ 10 Gauge - 304 (A2) Bi-Metal Stainless Steel



304 SS Bimetal EXTERNAL

IC Find #	Part No.	Description	mm	mm	Thread /mm	qty	qty
380	SDWAC1025SS	10-16 x 25	Wafer / PH2	2.0 - 4.0	Full	500	4000

* Also referenced on Page 134

Self Drilling Mush Head - Low Profile

■ 12 Gauge - 304 (A2) Bi-Metal Stainless Steel



304 SS Bimetal EXTERNAL

IC Find #	Part No.	Description	mm	mm	Thread /mm	qty	qty
390	SDMHC1238SS	12-14 x 38	Mush / SQ2	1.0 - 3.0	Full	250	4000

* Also referenced on Page 134

SELF DRILLING



Self Drilling Hex Head - Coarse

■ 10 Gauge - 304 (A2) Bi-Metal Stainless Steel



304 SS Bimetal EXTERNAL



304 SS Bimetal EXTERNAL With Sealing Washer



IC Find #	Part No.	IC Find #	Part No.	Description	mm	mm	Thread /mm	qty	qty
350	SDHXC1016SS	350W	SDHXC1016SSW	10-16 x 16	Hex 5/16	2.0 - 4.0	Full	250	4000

* Also referenced on Page 126

■ 12 Gauge - 304 (A2) Bi-Metal Stainless Steel



IC Find #	Part No.	IC Find #	Part No.	Description	mm	mm	Thread /mm	qty	qty
354	SDHXC1220SS	354W	SDHXC1220SSW	12-14 x 20	Hex 5/16	3.0 - 6.0	Full	250	4000

* Also referenced on Page 126

■ 14 Gauge - 304 (A2) Bi-Metal Stainless Steel



NEW

IC Find #	Part No.	IC Find #	Part No.	Description	mm	mm	Thread /mm	qty	qty
360	SDHXC14025SS	360W	SDHXC14025SSW	14-14 x 25	Hex 3/8	1.5 - 6.0	Full	500	1500
362	SDHXC14050SS	362W	SDHXC14050SSW	14-14 x 50	Hex 3/8	1.5 - 6.0	Full	1000	n/a
364	SDHXC14075SS	364W	SDHXC14075SSW	14-14 x 75	Hex 3/8	1.5 - 6.0	Full	500	n/a

* Also referenced on Page 126

Self Drilling Hex Head - 5 Series

■ 12 Gauge - 304 (A2) Bi-Metal Stainless Steel



304 SS Bimetal EXTERNAL



304 SS Bimetal EXTERNAL With Sealing Washer



NEW

IC Find #	Part No.	IC Find #	Part No.	Description	mm	mm	Thread /mm	qty	qty
448	SDHX5F12038SS	448W	SDHX5F12038SSW	12-24 x 38	Hex 5/16	6.0 - 12.0	Full	500	1500

* Also referenced on Page 131

Self Drilling CSK Head Wing

■ 10 Gauge - 302 (A2) Bi-Metal Stainless Steel



302 SS Bimetal INTERNAL



IC Find #	Part No.	Description	mm	mm	Thread /mm	qty	qty
386	SDCSWG1050SS	10-16 x 50	CSK / SQ2	2.0 - 4.00	Full	1000	4000

* Also referenced on Page 136

SDS Countersunk & Countersunk wing screws are not recommended for fixing decking /strip flooring to steel. The screws may break if there is movement between the timber and the steel supports due to change in moisture content of the timber or movement caused by thermal expansion.



SELF DRILLING SCREWS

Self Drilling Hex Head - Coarse Thread



■ 8 Gauge - Coarse Thread - Category 4

■ 8 Gauge - EPDM Sealing Washer - Coarse Thread - Category 4



IC4 EXTERNAL

IC4 EXTERNAL With Sealing Washer



IC Find #	Part No.	IC Find #	Part No.	Description	mm	mm	Thread /mm	qty	qty
100	SDHXC0812C4	100W	SDHXC0812C4W	8-18 x 12	Hex 1/4	0.75 - 2.50	Full	1000	8000



■ 10 Gauge - Coarse Thread - Category 4

■ 10 Gauge - EPDM Sealing Washer - Coarse Thread - Category 4



104*	SDHXC1016C4	104W*	SDHXC1016C4W	10-16 x 16	Hex 5/16	0.75 - 3.50	Full	1000	4000
106*	SDHXC1025C4	106W*	SDHXC1025C4W	10-16 x 25	Hex 5/16	0.75 - 3.50	Full	1000	3000

* Available in TRADE PACK see page 158



■ 12 Gauge - Coarse Thread - Category 4

■ 12 Gauge - EPDM Sealing Washer - Coarse Thread - Category 4



110*	SDHXC1220C4	110W*	SDHXC1220C4W	12-14 x 20	Hex 5/16	1.00 - 4.50	Full	500	2000
111	SDHXC1230C4	111W	SDHXC1230C4W	12-14 x 30	Hex 5/16	1.00 - 4.50	Full	1000	1000
112	SDHXC1235C4	112W	SDHXC1235C4W	12-14 x 35	Hex 5/16	1.00 - 4.50	Full	1000	1000
114	SDHXC1245C4	114W	SDHXC1245C4W	12-14 x 45	Hex 5/16	1.00 - 4.50	Full	1000	1000
116	SDHXC1255C4	116W*	SDHXC1255C4W	12-14 x 55	Hex 5/16	1.00 - 4.50	42	1000	1000
118	SDHXC1265C4	118W*	SDHXC1265C4W	12-14 x 65	Hex 5/16	1.00 - 4.50	50	1000	1000
120	SDHXC1275C4	120W	SDHXC1275C4W	12-14 x 75	Hex 5/16	1.00 - 4.50	50	500	500

* Available in TRADE PACK see page 158



■ 14 Gauge - Coarse Thread - Category 4

■ 14 Gauge - EPDM Sealing Washer - Coarse Thread - Category 4



124	SDHXC14025C4	124W*	SDHXC14025C4W	14-10 x 25	Hex 3/8	1.00 - 5.00	Full	500	1500
126	SDHXC14042C4	126W*	SDHXC14042C4W	14-10 x 42	Hex 3/8	1.00 - 5.00	Full	1000	1000
128	SDHXC14050C4	128W*	SDHXC14050C4W	14-10 x 50	Hex 3/8	1.00 - 5.00	Full	1000	1000
130	SDHXC14065C4	130W*	SDHXC14065C4W	14-10 x 65	Hex 3/8	1.00 - 5.00	50	1000	1000
132	SDHXC14075C4	132W*	SDHXC14075C4W	14-10 x 75	Hex 3/8	1.00 - 5.00	62	500	500
134	SDHXC14095C4	134W*	SDHXC14095C4W	14-10 x 95	Hex 3/8	1.00 - 5.00	81	500	500
436	SDHXC14115C4	436W	SDHXC14115C4W	14-14 x 115	Hex 3/8	1.00 - 5.00	70	250	250
437	SDHXC14125C4	437W	SDHXC14125C4W	14-14 x 125	Hex 3/8	1.00 - 5.00	70	250	250
438	SDHXC14135C4	438W	SDHXC14135C4W	14-14 x 135	Hex 3/8	1.00 - 5.00	70	250	250
440	SDHXC14150C4	440W	SDHXC14150C4W	14-14 x 150	Hex 3/8	1.00 - 5.00	70	250	250
442	SDHXC14175C4	442W	SDHXC14175C4W	14-14 x 175	Hex 3/8	1.00 - 5.00	70	250	250
444	SDHXC14205C4	444W	SDHXC14205C4W	14-14 x 205	Hex 3/8	1.00 - 5.00	70	200	200

* Available in TRADE PACK see page 158



Self Drilling Hex Head - Coarse Thread

■ 10 Gauge - Coarse Thread - Zinc Yellow

■ 10 Gauge - Coarse Thread - Category 3



ZINC

INTERNAL

IC3

EXTERNAL



IC Find #	Part No.	IC Find #	Part No.	Description	mm	mm	Thread /mm	qty	qty
150	SDHXC1016ZY	138	SDHXC1016C3	10-16 x 16	Hex 5/16	0.75 - 3.50	Full	1000	4000
		139	SDHXC1025C3	10-16 x 25	Hex 5/16	0.75 - 3.50	Full	1000	3000



□ 10 Gauge - Coarse Thread - Zinc Clear

ZINC

INTERNAL

148	SDHXC1016ZC	10-16 x 16	Hex 5/16	0.75 - 3.50	Full	1000	4000
149	SDHXC1025ZC	10-16 x 16	Hex 5/16	0.75 - 3.50	Full	1000	3000



Self Drilling Hex Head - Coarse Thread

■ 12 Gauge - Coarse Thread - Zinc Yellow

ZINC

INTERNAL



IC Find #	Part No.	Description	mm	mm	Thread /mm	qty	qty
152	SDHXC1220ZY	12-14 x 20	Hex 5/16	1.00 - 4.50	Full	500	2000
154	SDHXC1235ZY	12-14 x 35	Hex 5/16	1.00 - 4.50	Full	1000	1000



IC3

EXTERNAL



IC3

EXTERNAL
With Sealing Washer

■ 12 Gauge - Coarse Thread - Category 3



140	SDHXC1220C3			12-14 x 20	Hex 5/16	1.00 - 4.50	Full	500	2000
142	SDHXC1230C3	142W	SDHXC1230C3W	12-14 x 30	Hex 5/16	1.00 - 4.50	Full	1000	1000
144	SDHXC1235C3			12-14 x 35	Hex 5/16	1.00 - 4.50	Full	1000	1000



304 SS Bi-metal

EXTERNAL



304 SS Bi-metal

EXTERNAL With Sealing Washer

Self Drilling Hex Head - Coarse

10 Gauge - 304 (A2) Bi-Metal Stainless Steel

NEW



IC Find #	Part No.	IC Find #	Part No.	Description	mm	mm	Thread /mm	qty	qty
350	SDHXC1016SS	350W	SDHXC1016SSW	10-16 x 16	Hex 5/16	2.0 - 4.0	Full	250	4000

* Refer Page 122 - 123 for full Stainless Bi-metal SDS range



12 Gauge - 304 (A2) Bi-Metal Stainless Steel

NEW

IC Find #	Part No.	IC Find #	Part No.	Description	mm	mm	Thread	qty	qty
354	SDHXC1220SS	354W	SDHXC1220SSW	12-14 x 20	Hex 5/16	3.0 - 6.0	Full	250	4000

* Refer Page 122 - 123 for full Stainless Bi-metal SDS range



14 Gauge - 304 (A2) Bi-Metal Stainless Steel

NEW

IC Find #	Part No.	IC Find #	Part No.	Description	mm	mm	Thread	qty	qty
360	SDHXC14025SS	360W	SDHXC14025SSW	14-14 x 25	Hex 3/8	1.5 - 6.0	Full	500	1500
362	SDHXC14050SS	362W	SDHXC14050SSW	14-14 x 50	Hex 3/8	1.5 - 6.0	Full	1000	n/a
364	SDHXC14075SS	364W	SDHXC14075SSW	14-14 x 75	Hex 3/8	1.5 - 6.0	Full	500	n/a

* Refer Page 122 - 123 for full Stainless Bi-metal SDS range

stainless steel SDS bimetal screws

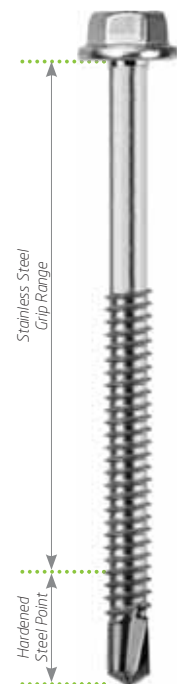



Self Drilling Hex Head - Fine Thread

■ 10 Gauge - Fine Thread - Category 4

■ 10 Gauge - EPDM Sealing Washer - Fine Thread - Category 4



IC4 EXTERNAL

IC4 EXTERNAL With Sealing Washer



IC Find #	Part No.	IC Find #	Part No.	Description	mm	mm	Thread /mm	qty	qty
170	SDHXF1025C4	170W	SDHXF1025C4W	10-24 x 25	Hex 5/16	1.20 -3.50	Full	1000	3000



■ 12 Gauge - Fine Thread - Category 4

■ 12 Gauge - EPDM Sealing Washer - Fine Thread - Category 4



172*	SDHXF1230C4	172W*	SDHXF1230C4W	12-24 x 30	Hex 5/16	1.20 - 4.50	Full	1000	1000
------	-------------	-------	--------------	------------	----------	-------------	------	------	------

* Available in TRADE PACK see page 158



■ 14 Gauge - Fine Thread - Category 4

■ 14 Gauge - EPDM Sealing Washer - Fine Thread - Category 4



176*	SDHXF14025C4	176W	SDHXF14025C4W	14-20 x 25	Hex 3/8	1.20 - 5.00	Full	500	1500
177	SDHXF14045C4	177W	SDHXF14045C4W	14-20 x 45	Hex 3/8	1.20 - 5.00	Full	1000	1000
175	SDHXF14065C4	175W	SDHXF14065C4W	14-20 x 65	Hex 3/8	1.20 - 5.00	50	1000	1000
178	SDHXF14115C4	178W	SDHXF14115C4W	14-20 x 115	Hex 3/8	1.20 - 5.00	75	250	250

* Available in TRADE PACK see page 158

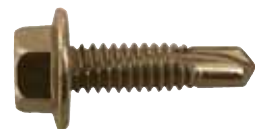

Self Drilling Hex Head - Fine Thread

■ 14 Gauge - Fine Thread - Zinc Yellow

ZINC INTERNAL



IC Find #	Part No.	Description	mm	mm	Thread /mm	qty	qty
186	SDHXF14025ZY	14-20 x 25	Hex 3/8	1.20 - 5.00	Full	500	1500



NEW

■ 14 Gauge - Fine Thread - Category 3



IC3 INTERNAL



IC Find #	Part No.	Description	mm	mm	Thread /mm	qty	qty
173	SDHXF14022C3	14-20 x 22	Hex 3/8	1.20 - 5.00	Full	500	1500



CYCLONIX®

Self Drilling Hex Head

■ 14 Gauge - Category 4



NAUTILUS®
EXTEND 4

IC4 EXTERNAL

IC Find #	Part No.	Description	mm	mm	Thread /mm	qty
370X	SDHXTG14055C4X	14-10 x 55	Hex 3/8	0.75 - 5.00	42	500
374X*	SDHXTG14065C4X	14-10 x 65	Hex 3/8	0.75 - 5.00	42	500

*Part No. SDHXTG14065C4X is suitable for cyclonic applications subject to letter of opinion from FYFE Consulting Engineers (Ref. 51176-1). This part is not referenced in the NT Deemed to comply manual (DTCM).

EXTREME WEATHER SCREW ASSEMBLY

CYCLONIX®

APPROVED AND REFERENCED IN THE NT DEEMED TO COMPLY MANUAL (DTCM)

ICCONS® range of Cyclonix® Screws have been specially engineered and proven suitable for Australia's most severe cyclonic regions.

All screws have undergone extensive and fully independent testing by The University of Adelaide (ENGTEST) and shown to meet or exceed all current relevant Australian Standards for both strength and serviceability.

CYCLONIX® Deks Washer Assembly Material.

80 Shore Hardness Non - Conductive EPDM compound. In compliance with Bluescope™ Steel Technical Bulletin TB16 for Fasteners.

SDS and Type 17 Hex 3/8 Head with Top Shank Protection Teeth

One piece washer assembly for both Corrugated and Square Rib Roofing Sheet Profiles

- ★ EPDM bonnet designed to suit the under-head profile of the Cyclonix® screw.
- ★ Aluminium Series 5000 pressure plate for high tensile and yield strengths.
- ★ Tapered Angle prevents washer spew.
- ★ Inner ring seals against screw shank.
- ★ Deep inner sealing ring for additional watertight security.
- ★ Thick outer seal provides a secure seal against all profiles.

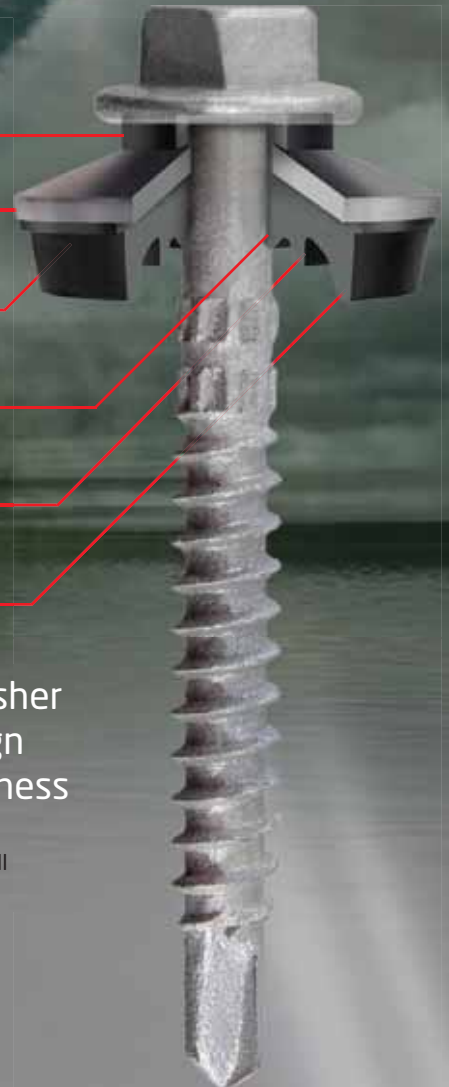

6 Star EPDM Sealing Washer and Pressure Plate design for optimum water tightness and security

Independently Tested and conforming to all current relevant Australian Standards



NAUTILUS®
EXTEND 4



Batten-Stars®

NAUTILUS® 3

■ 12 Gauge - Metal Top Hat Batten to Steel or Timber - Category 3

Self-drilling universal screw for fastening metal roofing battens to steel purlins up to 1.9mm or to timber roof trusses.

IC3 EXTERNAL



IC Find #	Part No.	Description	mm	mm	Thread /mm	qty	qty
160	SDHXUNI1240C3	12-11 x 40	Hex 5/16	0.55 - 1.90	Full	1000	1000

* Available in TRADE TUB see page 160



RoofStars®

NAUTILUS® XTEND 4

■ 13 Gauge - Metal Roof Sheet to Steel or Timber Battens - Category 4

Self-drilling universal roofing screw with sealing washer for fastening metal roof sheet to thin metal battens, steel purlins or alternatively can be used to fasten to timber battens.

IC4 EXTERNAL With Sealing Washer



IC Find #	Part No.	Description	mm	mm	Thread /mm	qty	qty
162W*	SDHXUNI1350C4W	13-11 X 50	Hex 5/16	0.55 - 1.90	33	1000	1000

* Available in TRADE PACK & TRADE TUB see page 160



Wall-Stars®

NAUTILUS® 4

■ 13 Gauge - thin metal battens, steel purlins - Category 4

Self Drilling universal cladding screw for fastening cladding to thin metal battens, steel purlins or alternatively can be used to fasten to timber Battens.

IC4 EXTERNAL

IC4 EXTERNAL With Sealing Washer



IC Find #	Part No.	IC Find #	Part No.	Description	mm	mm	Thread /mm	qty	qty
166	SDHXUNI1325C4	166W	SDHXUNI1325C4W	13-11 X 25	Hex 5/16	0.55 - 1.90	Full	500	1500

* Available in TRADE TUB see page 160

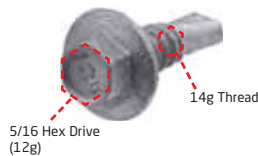

Hex Shed Head

NEW

NAUTILUS® 4

■ 14 Gauge - with 12 Gauge 5/16 hex head - Category 4

IC4 EXTERNAL



IC Find #	Part No.	Description	mm	mm	Thread /mm	qty	qty
122	SDHXC12-14022C4	14-14 x 22	Hex 5/16	1.0 - 5.0	Full	500	1500

NEW

RT-18V E5 CORDLESS RIVET TOOL

18v Cordless Blind Rivet Tool

SEE PAGE 106 FOR FULL DETAILS



SELF DRILLING



SELF DRILLING SCREWS



Self Drilling Hex Head Top Grip

■ 12 Gauge - with EPDM Sealing Washer - Coarse Thread - Category 4
Self Drilling Hex - top grip roofing screw.



IC4 EXTERNAL
With Sealing Washer



IC Find #	Part No.	Description	mm	mm	Thread /mm	qty	qty
156W*	SDHXTG1242C4W	12-14 x 42	Hex 5/16	1.00 - 4.50	Full	1000	1000
158W*	SDHXTG1253C4W	12-14 x 53	Hex 5/16	1.00 - 4.50	Full	1000	1000

* Available in TRADE PACK & TRADE TUB see page 159

Self Drilling Panel Screw with Dekfast® Multiseal™ Washer

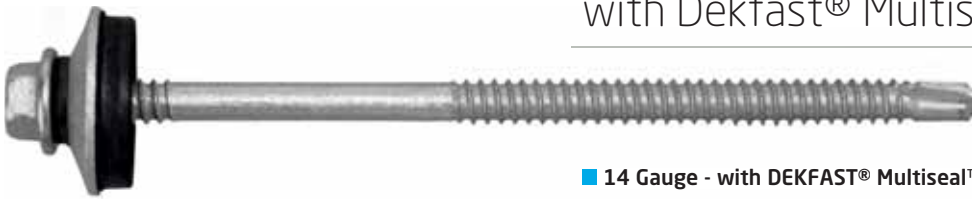

■ 14 Gauge - with DEKFAST® Multiseal™ Washer - Coarse Thread - Category 4

IC4 EXTERNAL
With Multiseal® Washer



IC Find #	Part No.	Description	mm	mm	Thread /mm	qty	qty
437DFW	SDHXC14125C4DFW	14 - 14 x 125	Hex 3/8	1.00 - 5.00	70	250	250



Dekfast® Multiseal™ Washer

■ Aluminium washer with Multiseal™ EPDM washer
suitable for 14g hex head screws

Aluminium EXTERNAL



IC Find #	Part No.	Description	mm	Screw Gauge	qty	qty
499	YDM-A25-B14-G	Aluminium with Multiseal™ EPDM washer	25	14g	250	n/a

Also referenced on page 141

Download the ICCONS® App today!

Features:

- Adhesive Volume Calculator
- What's New
- View Our Catalogue
- Find A Distributor
- NCC F.A.Q. Sheet & NCC Products
- Contact us

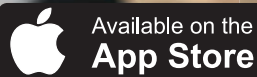



5 Series

- For Fastening Into Thick Steel
- FASTER DRILLING
- EASY PENETRATION
- SUPERIOR SWarf EJECTION
- LOW FORCE



Self Drilling Hex Head - 5 Series

■ 12 Gauge - 5 Series - Fine Thread - Category 4

■ 12 Gauge - 5 Series with EPDM Sealing Washer Fine Thread - Category 4

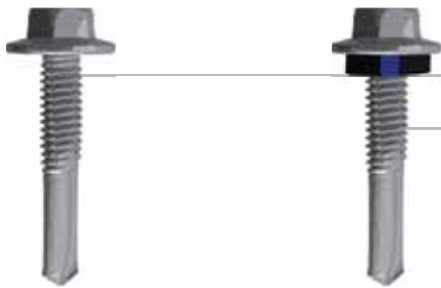

IC4 EXTERNAL IC4 EXTERNAL With Sealing Washer

IC Find #	Part No.	IC Find #	Part No.	Description	mm	mm	Thread /mm	qty	qty
190*	SDHX5F12032C4	190W*	SDHX5F12032C4W	12-24 x 32	Hex 5/16	3.00 - 12.00	Full	500	1500
192*	SDHX5F12050C4	192W*	SDHX5F12050C4W	12-24 x 50	Hex 5/16	3.00 - 12.00	Full	1000	1000
194*	SDHX5F12065C4	194W*	SDHX5F12065C4W	12-24 x 65	Hex 5/16	3.00 - 12.00	50	1000	1000
196*	SDHX5F12085C4	196W*	SDHX5F12085C4W	12-24 x 85	Hex 5/16	3.00 - 12.00	50	500	500

* Available in TRADE PACK & TRADE TUB see page 159

Self Drilling Hex Head - 5 Series

■ 12 Gauge - 304 (A2) Bi-Metal Stainless Steel

NEW



304 SS Bimetal EXTERNAL 304 SS Bimetal EXTERNAL With Sealing Washer

IC Find #	Part No.	IC Find #	Part No.	Description	mm	mm	Thread /mm	qty	qty
448	SDHX5F12038SS	448W	SDHX5F12038SSW	12-24 x 38	Hex 5/16	6.0 - 12.0	Full	500	1500

* Refer Page 122 - 123 for full Stainless Bi-metal SDS range



SELF DRILLING SCREWS

Self Drilling CSK Self Embed Head

■ 8 Gauge - 6 Nibb Self Embed Head - Coarse Thread - Zinc Yellow

■ 8 Gauge - 6 Nibb Self Embed Head - Coarse Thread - Category 3

NAUTILUS® 3

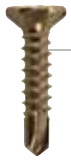

ZINC INTERNAL



IC3 EXTERNAL

IC Find #	Part No.	IC Find #	Part No.	Description	mm	mm	Thread /mm	qty	qty
326*	SDCSSE0820ZY	330*	SDCSSE0820C3	8-18 x 20	CSK / PH2	0.75 - 2.50	Full	1000	8000
328*	SDCSSE0830ZY	332*	SDCSSE0830C3	8-18 x 30	CSK / PH2	0.75 - 2.50	Full	1000	4000

* Available in TRADE PACK see page 162

Self Drilling CSK Head Villaboard® 4 Nibb

■ 8 Gauge - Self Embed Head Collated - Zinc Yellow



ZINC INTERNAL



IC Find #	Part No.	Description	mm	mm	Thread /mm	qty	qty
344C	SDCSSE0820ZYCOL	8-15 x 20	PH2	0.75 - 2.30	Full	1000	10 000
346C	SDCSSE0830ZYCOL	8-15 x 30	PH2	0.75 - 2.30	Full	1000	10 000

See page 156 for full collated offering

Self Drilling CSK Head # FINE THREAD

■ 6 Gauge - Fine Thread - Zinc Yellow



ZINC INTERNAL

IC Find #	Part No.	Description	mm	mm	Thread /mm	qty	qty
398	SDCSF0650ZY	6-20 x 50	CSK / PH2	0.75 - 2.30	Full	1000	3000



■ 10 Gauge - Fine Thread - Zinc Yellow

304*	SDCSF1030ZY	10-24 x 30	CSK / PH2	1.20 - 3.50	Full	1000	4000
306*	SDCSF1040ZY	10-24 x 40	CSK / PH2	1.20 - 3.50	Full	1000	3000
308*	SDCSF1050ZY	10-24 x 50	CSK / PH2	1.20 - 3.50	Full	500	2000
310*	SDCSF1065ZY	10-24 x 65	CSK / PH2	1.20 - 3.50	Full	500	1500

* Available in TRADE PACK see page 162

Self Drilling CSK Head # COARSE THREAD

■ 10 Gauge - Coarse Thread - Zinc Yellow

■ 10 Gauge - Coarse Thread - Category 3

NAUTILUS® 3



ZINC INTERNAL



IC3 EXTERNAL

IC Find #	Part No.	IC Find #	Part No.	Description	mm	mm	Thread /mm	qty	qty
314*	SDCSC1030ZY	320*	SDCSC1030C3	10-16 x 30	CSK / PH2	0.75 - 3.50	Full	1000	4000
316*	SDCSC1040ZY	322*	SDCSC1040C3	10-16 x 40	CSK / PH2	0.75 - 3.50	Full	1000	3000

* Available in TRADE PACK see page 162

SDS Countersunk & Countersunk wing screws are not recommended for fixing decking /strip flooring to steel. The screws may break if there is movement between the timber and the steel supports due to change in moisture content of the timber or movement caused by thermal expansion.



Coming Soon



IC3

INTERNAL / EXTERNAL

FIBRE-STARS For Fibre Cement Sheet to 0.75 -2.5mm steel

■ 8 Gauge - Self Embed Head - C3



IC Find #	Part No.	Description	mm	mm	Thread /mm	qty	qty
433	SDFLSE0825GC3	8-18 x 25	No.2 Sq	0.75 - 2.50	Full	1000	2000

Coming Soon



IC3

INTERNAL / EXTERNAL

FIBRE-STARS For Fibre Cement Sheet to 0.75 -2.5mm steel

■ 8 Gauge - Self Embed Head Collated - C3



IC Find #	Part No.	Description	mm	mm	Thread /mm	qty	qty
433C	SDFLSE0825GC3COL	8-18 x 25	PH2	0.75 - 2.50	Full	1000	TBA

See page 156 for full collated offering

FIBRE-STARS For Fibre Cement Sheet to 0.55 -0.75mm steel

■ 8 Gauge - Self Embed Head - Kaitex C3

Reduced Drill Point & Buttress Thread For Fixing To Thin Steel



Kaitex C3

INTERNAL / EXTERNAL



IC Find #	Part No.	Description	mm	mm	Thread /mm	qty	qty
430	SDFLSE0820C3	8-18 x 20	PH2	0.55 - 0.75	Full	1000	2000
434	SDFLSE0830C3	8-18 x 30	PH2	0.55 - 0.75	Full	1000	2000

FIBRE-STARS

INTERNAL / EXTERNAL USE C3

Specialist Fast Clean – Cut Fibre Cement Sheet Screw

- Aggressive rotating cutting head leaves screw head fully self-embedded
- Reduced mushrooming of board at edge of hole
- Kaitex C3 Tested to ASTM B1137-1000 Hours Salt Spray Resistance

For compressed sheeting that may require clearance hole always refer to FC board manufacturers recommendations.

Phillips Driver Bit FREE in Each Tub
NO Pre-drilling Required



SELF DRILLING SCREWS

Self Drilling Wafer Head - Coarse Thread



■ 10 Gauge - Coarse Thread - Zinc Yellow

■ 10 Gauge - Coarse Thread - Category 3

NAUTILUS® 3

ZINC INTERNAL

IC3 EXTERNAL



IC Find #	Part No.	IC Find #	Part No.	Description	mm	mm	Thread /mm	qty	qty
210	SDWAC1016ZY	200*	SDWAC1016C3	10-16 x 16	Wafer / PH2	0.75 - 3.50	Full	1000	8000
212	SDWAC1022ZY	202*	SDWAC1022C3	10-16 x 22	Wafer / PH2	0.75 - 3.50	Full	1000	6000
214	SDWAC1030ZY	204*	SDWAC1030C3	10-16 x 30	Wafer / PH2	0.75 - 3.50	Full	1000	3000
216	SDWAC1040ZY	206*	SDWAC1040C3	10-16 x 40	Wafer / PH2	0.75 - 3.50	Full	1000	3000

* Available in TRADE PACK see page 161



Self Drilling Wafer Head - Fine Thread

■ 10 Gauge - Coarse Thread - Zinc Yellow

ZINC INTERNAL



IC Find #	Part No.	Description	mm	mm	Thread /mm	qty	qty
220	SDWAF1016ZY	10-24 x 16	Wafer / PH2	0.75 - 3.50	Full	1000	8000



Self Drilling Wafer Head

■ 10 Gauge - 304 (A2) Bi-Metal Stainless Steel

304 SS Bimetal EXTERNAL



IC Find #	Part No.	Description	mm	mm	Thread /mm	qty	qty
380	SDWAC1025SS	10-16 x 25	Wafer / PH2	2.0 - 4.0	Full	500	4000

* Refer Page 122 - 123 for full Stainless Bi-metal SDS range



Self Drilling Wafer Head

■ 12 Gauge with 10 gauge head - Coarse Thread - Zinc Yellow

■ 12 Gauge with 10 gauge head - Coarse Thread - Category 3

NAUTILUS® 3

ZINC INTERNAL

IC3 EXTERNAL



IC Find #	Part No.	IC Find #	Part No.	Description	mm	mm	Thread /mm	qty	qty
228	SDWAC1218ZY	224	SDWAC1218C3	12-14 x 18	Wafer / PH2	1.00 - 4.50	Full	1000	6000



Self Drilling Mush Head - Low Profile

■ 12 Gauge - 304 (A2) Bi-Metal Stainless Steel

304 SS Bimetal EXTERNAL



IC Find #	Part No.	Description	mm	mm	Thread /mm	qty	qty
390	SDMHC1238SS	12-14 x 38	Mush / SQ2	1.0 - 3.0	Full	250	4000

* Refer Page 122 - 123 for full Stainless Bi-metal SDS range



Self Drilling Button Head



■ 8 Gauge - Coarse Thread - Zinc Yellow

■ 8 Gauge - Coarse Thread - Category 3

NAUTILUS® 3

ZINC INTERNAL		IC3 EXTERNAL		mm		mm	Thread /mm	qty	qty
IC Find #	Part No.	IC Find #	Part No.	Description	mm	mm	Thread /mm	qty	qty
240*	SDBH0812ZY	230*	SDBH0812C3	8-18 x 12	Button / PH2	0.75 - 2.50	Full	1000	8000
242*	SDBH0816ZY	232*	SDBH0816C3	8-18 x 16	Button / PH2	0.75 - 2.50	Full	1000	6000
244*	SDBH0820ZY	234*	SDBH0820C3	8-18 x 20	Button / PH2	0.75 - 2.50	Full	1000	6000
246*	SDBH0825ZY	236*	SDBH0825C3	8-18 x 25	Button / PH2	0.75 - 2.50	Full	1000	4000
248*	SDBH0832ZY	238*	SDBH0832C3	8-18 x 32	Button / PH2	0.75 - 2.50	Full	1000	3000

* Available in TRADE PACK see page 160



Self Drilling Button Head

□ 10 Gauge - Coarse Thread - Zinc Clear

ZINC INTERNAL		mm		mm	Thread /mm	qty	qty
IC Find #	Part No.	Description	mm	mm	Thread /mm	qty	qty
250	SDBH1016ZC	10-16 x 16	Button / SQ2	0.75 - 2.50	Full	1000	n/a



Self Drilling Flathead

■ 10 Gauge - Coarse Thread - Zinc Yellow

■ 10 Gauge - Coarse Thread - Category 3

NAUTILUS® 3

ZINC INTERNAL		IC3 EXTERNAL		mm		mm	Thread /mm	qty	qty
IC Find #	Part No.	IC Find #	Part No.	Description	mm	mm	Thread /mm	qty	qty
254*	SDFHC1016ZY	260*	SDFHC1016C3	10-16 x 16	Flat / PH2	0.75 - 3.00	Full	1000	8000
		262*	SDFHC1022C3	10-16 x 22	Flat / PH2	0.75 - 3.00	Full	1000	6000
		264*	SDFHC1030C3	10-16 x 30	Flat / PH2	0.75 - 3.00	Full	1000	3000

* Available in TRADE PACK & TRADE TUB see page 161



Self Drilling Flathead

■ 10 Gauge - Collated - Coarse Thread - Zinc Yellow



ZINC INTERNAL		mm		mm	Thread /mm	qty	qty
IC Find #	Part No.	Description	mm	mm	Thread /mm	qty	qty
256C	SDFHC1022ZYCOL	10-16 x 22	Flat / PH2	0.75 - 3.00	Full	1000	10,000

See page 156 for full collated offering



Self Drilling Steel Frame

■ Pancake Head Steel Frame Truss Fixing - Category 3

NAUTILUS® 3

IC3 EXTERNAL		mm		mm	qty	qty
IC Find #	Part No.	Description	mm	mm	qty	qty
266	SDSFTM0618C3	M6 x 18mm Pancake Head Steel Frame Truss Fixing	Flat / PH3	(2x) 0.55 Up to (2x) 1.00	2500	n/a



SELF DRILLING SCREWS



Self Drilling CSK Head

■ 10 Gauge - Fine Thread - Zinc Yellow

ZINC INTERNAL							
IC Find #	Part No.	Description	mm	mm	Thread /mm	qty	qty
304*	SDCSF1030ZY	10-24 x 30	CSK / PH2	1.20 - 3.50	Full	1000	4000
306*	SDCSF1040ZY	10-24 x 40	CSK / PH2	1.20 - 3.50	Full	1000	3000
308*	SDCSF1050ZY	10-24 x 50	CSK / PH2	1.20 - 3.50	Full	500	2000
310*	SDCSF1065ZY	10-24 x 65	CSK / PH2	1.20 - 3.50	Full	500	1500

* Available in TRADE PACK see page 162

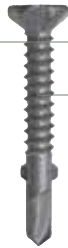

Self Drilling CSK Head Wing

■ 6 Gauge - Coarse Thread - Zinc Yellow

■ 8 Gauge - Coarse Thread - Category 3

NAUTILUS® 3

ZINC INTERNAL			IC3 EXTERNAL						
IC Find #	Part No.	IC Find #	Part No.	Description	mm	mm	Thread /mm	qty	qty
282*	SDCSWG0642ZY			6-20 x 42	CSK / PH2	0.75 - 2.30	Full	1000	4000
		268*	SDCSWG0832C3	8-18 x 32	CSK / PH2	0.75 - 2.50	Full	1000	4000

* Available in TRADE PACK see page 161

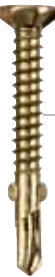

■ 10 Gauge - Coarse Thread - Zinc Yellow

■ 10 Gauge - Coarse Thread - Category 3

NAUTILUS® 3

286	SDCSWG1040ZY	272*	SDCSWG1040C3	10-16 x 40	CSK / PH2	0.75 - 3.50	Full	1000	3000
288	SDCSWG1045ZY	274*	SDCSWG1045C3	10-16 x 45	CSK / PH2	0.75 - 3.50	Full	500	2000
		276*	SDCSWG1055C3	10-16 x 55	CSK / PH2	0.75 - 3.50	Full	500	1500
		278*	SDCSWG1075C3	10-16 x 75	CSK / PH2	0.75 - 3.50	Full	1000	1000

* Available in TRADE PACK see page 161



Self Drilling CSK Head Wing

■ 10 Gauge - 302 Bi-Metal Stainless Steel

302 SS Bimetal INTERNAL							
IC Find #	Part No.	Description	mm	mm	Thread /mm	qty	qty
386	SDCSWG1050SS	10-16 x 50	CSK / SQ2	2.0 - 4.00	Full	1000	4000

* Refer Page 122 - 123 for full Stainless Bi-metal SDS range

SDS Countersunk & Countersunk wing screws are not recommended for fixing decking /strip flooring to steel. The screws may break if there is movement between the timber and the steel supports due to change in moisture content of the timber or movement caused by thermal expansion.



Self Drilling Pan Head

■ 8 Gauge - Coarse Thread - Zinc Yellow

ZINC

INTERNAL



IC Find #	Part No.	Description	mm	mm	Thread /mm	qty	qty
336	SDPH0812ZY	8-18 x 12	Pan / PH2	0.75 - 2.50	Full	1000	8000
338	SDPH0816ZY	8-18 x 16	Pan / PH2	0.75 - 2.50	Full	1000	8000



NEW

Self Drilling Pan Head - Coarse

■ 8 Gauge - 304 (A2) Bi-Metal Stainless Steel

304 SS Bimetal

EXTERNAL



IC Find #	Part No.	Description	mm	mm	Thread /mm	qty	qty
402	SDPH0816SS	8-18 x 16 Self Drilling Pan head NEW	PH2	1.5 - 3.0	Full	1000	8000
403	SDPH0819SS	8-18 x 19 Self Drilling Pan head NEW	PH2	1.5 - 3.0	Full	1000	8000
404	SDPH0825SS	8-18 x 25 Self Drilling Pan head NEW	PH2	1.5 - 3.0	Full	1000	6000

* Refer Page 122 - 123 for full Stainless Bi-metal SDS range



Self Drilling Bugle Head

■ 6 Gauge - Zinc Yellow

ZINC

INTERNAL



IC Find #	Part No.	Description	mm	mm	Thread /mm	qty	qty
292*	SDBU0625ZY	6-20 x 25	Bugle / PH2	0.75 - 2.30	Full	1000	6000
294*	SDBU0632ZY	6-20 x 32	Bugle / PH2	0.75 - 2.30	Full	1000	6000
298*	SDBU0645ZY	6-20 x 45	Bugle / PH2	0.75 - 2.30	Full	1000	3000

* Available in TRADE PACK see page 162



■ 8 Gauge - Zinc Yellow

300	SDBU0875ZY	8-18 x 75	Bugle / PH2	0.75 - 2.50	Full	1000	1000
-----	------------	-----------	-------------	-------------	------	------	------



Self Drilling Bugle Head

■ 6 Gauge - Collated Strip - Zinc Yellow



ZINC

INTERNAL



IC Find #	Part No.	Description	mm	mm	Thread /mm	qty	qty
292C	SDBU0625ZYCOL	6-20 x 25	Bugle / PH2	0.75 - 2.30	Full	1000	10 000
294C	SDBU0632ZYCOL	6-20 x 32	Bugle / PH2	0.75 - 2.30	Full	1000	10 000
296C	SDBU0641ZYCOL	6-20 x 41	Bugle / PH2	0.75 - 2.30	Full	1000	10 000

See page 156 for full collated offering



SELF DRILLING SCREWS

STET Aesthetic Architectural Tamper Resistant Screw - Coarse Thread Flat Head

■ 12 Gauge - Coarse Thread - Category 4

■ 12 Gauge - Coarse Thread - with A12 washer Category 4



NEW **FRIULSIDER**
YOUR FIXING FACTORY



IC4 EXTERNAL

IC4 EXTERNAL with A12 washer

IC Find #	Part No.	IC Find #	Part No.	Description	mm	mm	Thread /mm	qty	qty
470	SDTETFH12025C4	470W	SDTETFH12025C4W	12-18 x 25	STET Tool	1.50 - 4.00	Full	1000	8000
472	SDTETFH12032C4	472W	SDTETFH12032C4W	12-18 x 32	STET Tool	2.00 - 6.00	Full	1000	8000

STET Aesthetic Architectural Tamper Resistant Screw - 5 Series Flat Head

■ 12 Gauge - Fine Thread -5 Series - Category 4

■ 12 Gauge - Fine Thread -5 Series- with A12 washer Category 4



NEW **FRIULSIDER**
YOUR FIXING FACTORY



IC4 EXTERNAL

IC4 EXTERNAL with A12 washer

IC Find #	Part No.	IC Find #	Part No.	Description	mm	mm	Thread /mm	qty	qty
490	SDTETFH5F12038C4	490W	SDTETFH5F12038C4W	12-18 x 38	STET Tool	4.00 - 12mm	Full	1000	8000

STET Clamping Socket Driver

For use with STET Screws



NEW



Part No.	Description	qty
SD-TET-TOOL	Special tool for STET Screws (1/4" drive)	1





stainless steel Type 17 screws



Type 17 Hex Head

■ 14 Gauge - 304 (A2) Stainless Steel

NEW

304 SS

EXTERNAL

304 SS

EXTERNAL
With Sealing Washer



IC Find #	Part No.	IC Find #	Part No.	Description	mm	mm	Thread /mm	qty	qty
684	T17HX14025SS	684W	T17HX14025SSW	14-10 x 25	Hex 5/16	23	Full	500	1500
686	T17HX14050SS	686W	T17HX14050SSW	14-10 x 50	Hex 5/16	35	Full	1000	1000
688	T17HX14075SS	688W	T17HX14075SSW	14-10 x 75	Hex 5/16	35	50	500	500

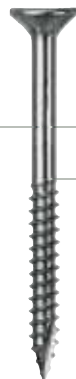

Type 17 Bugle Batten 302 & 316 Stainless Steel

■ 14 Gauge - Coarse Thread - 302 (A2) Stainless Steel

■ 14 Gauge - Coarse Thread - 316 (A2) Stainless Steel

Now In TUBS!



302 SS

EXTERNAL

316 SS

EXTERNAL



IC Find #	Part No.	IC Find #	Part No.	Description	mm	mm	Thread /mm	qty	qty
573	T17BB14050SS			14-10 x 50	Bugle / 5mm Int	30	30	1000	1000
582*	T17BB14075SS	581	T17BB14075SS-316	14-10 x 75	Bugle / 5mm Int	35	50	1000	1000
584*	T17BB14100SS			14-10 x 100	Bugle / 5mm Int	35	65	500	500
		583	T17BB14100SS-316	14-10 x 100	Bugle / 5mm Int	35	65	800	800

* Available in TRADE PACK see page 164 Also referenced on Page 145



TYPE 17 SCREWS

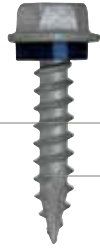
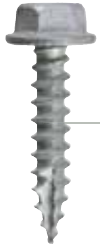

Type 17 Hex Head

■ 10 Gauge - Coarse Thread - Category 4

■ 10 Gauge - EPDM Sealing Washer - Coarse Thread - Category 4



IC4

EXTERNAL

IC4

EXTERNAL
With Sealing Washer



IC Find #	Part No.	IC Find #	Part No.	Description	mm	mm	Thread /mm	qty	qty
500*	T17HX1025C4	500W*	T17HX1025C4W	10-12 x 25	Hex 5/16	23	Full	1000	3000

* Available in TRADE PACK see page 163

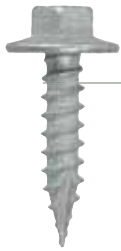

■ 12 Gauge - Coarse Thread - Category 4

■ 12 Gauge - EPDM Sealing Washer - Coarse Thread - Category 4



504*	T17HX1225C4	504W*	T17HX1225C4W	12-11 x 25	Hex 5/16	23	Full	500	2000
506*	T17HX1235C4	506W	T17HX1235C4W	12-11 x 35	Hex 5/16	30	Full	1000	1000
508*	T17HX1240C4	508W*	T17HX1240C4W	12-11 x 40	Hex 5/16	30	Full	1000	1000
510	T17HX1245C4	510W*	T17HX1245C4W	12-11 x 45	Hex 5/16	30	30	1000	1000
512*	T17HX1250C4	512W	T17HX1250C4W	12-11 x 50	Hex 5/16	30	33	1000	1000
514*	T17HX1265C4	514W	T17HX1265C4W	12-11 x 65	Hex 5/16	30	43	1000	1000

* Available in TRADE PACK see page 163



■ 14 Gauge - Coarse Thread - Category 4

■ 14 Gauge - EPDM Sealing Washer - Coarse Thread - Category 4



516*	T17HX14025C4	516W*	T17HX14025C4W	14-10 x 25	Hex 3/8	23	Full	500	1500
518	T17HX14040C4	518W	T17HX14040C4W	14-10 x 40	Hex 3/8	35	Full	1000	1000
520	T17HX14050C4	520W*	T17HX14050C4W	14-10 x 50	Hex 3/8	35	33	1000	1000
522	T17HX14065C4	522W*	T17HX14065C4W	14-10 x 65	Hex 3/8	35	43	1000	1000
524*	T17HX14075C4	524W*	T17HX14075C4W	14-10 x 75	Hex 3/8	35	50	500	500
526	T17HX14090C4	526W*	T17HX14090C4W	14-10 x 90	Hex 3/8	35	60	500	500
528	T17HX14100C4	528W*	T17HX14100C4W	14-10 x 100	Hex 3/8	35	60	250	250
530	T17HX14115C4	530W	T17HX14115C4W	14-10 x 115	Hex 3/8	35	60	250	250
532	T17HX14125C4	532W	T17HX14125C4W	14-10 x 125	Hex 3/8	35	60	250	250
534	T17HX14150C4	534W	T17HX14150C4W	14-10 x 150	Hex 3/8	35	100	250	250

* Available in TRADE PACK see page 163



TYPE 17 SCREWS



Type 17 Hex Head

■ 12 Gauge - Coarse Thread - Zinc Yellow

ZINC

INTERNAL



IC Find #	Part No.	Description	mm	mm	Thread /mm	qty	qty
540	T17HX1225ZY	12-11 x 25	Hex 5/16	23	Full	500	2000
542	T17HX1240ZY	12-11 x 40	Hex 5/16	30	Full	1000	1000
544	T17HX1250ZY	12-11 x 50	Hex 5/16	30	33	1000	1000
545	T17HX1265ZY	12-11 x 65	Hex 5/16	30	43	1000	1000



■ 10 Gauge - Coarse Thread - Category 3

NAUTILUS® 3

IC3

EXTERNAL



IC Find #	Part No.	Description	mm	mm	Thread /mm	qty	qty
501	T17HX1025C3	10-12 x 25	Hex 5/16	23	Full	1000	3000



■ 12 Gauge - Coarse Thread - Category 3

NAUTILUS® 3

505	T17HX1225C3	12-11 x 25	Hex 5/16	23	Full	500	2000
507	T17HX1235C3	12-11 x 35	Hex 5/16	30	Full	500	1500
509	T17HX1240C3	12-11 x 40	NEW Hex 5/16	30	Full	1000	1000



■ 14 Gauge - Coarse Thread - Category 3

NAUTILUS® 3

662	T17HX14030C3	14-10 x 30	NEW Hex 3/8	25	full	1000	1000
521	T17HX14050C3	14-10 x 50	NEW Hex 3/8	35	33	1000	1000
525	T17HX14075C3	14-10 x 75	Hex 3/8	35	50	500	500
527	T17HX14090C3	14-10 x 90	NEW Hex 3/8	35	60	500	500
529	T17HX14100C3	14-10 x 100	NEW Hex 3/8	35	60	250	250
535	T17HX14150C3	14-10 x 150	Hex 3/8	35	100	250	250

Dekfast® Multiseal™ Washer

■ Aluminium washer with Multiseal™ EPDM washer suitable for 14g hex head screws

Aluminium

EXTERNAL



IC Find #	Part No.	Description	mm	Screw Gauge	qty	qty
499	YDM-A25-B14-G	Aluminium with Multiseal™ EPDM washer	25	14g	250	n/a

Also referenced on page 130



TYPE 17 SCREWS



CYCLONIX® Type 17 Hex Head



NAUTILUS®
EXTEND 4

IC4 EXTERNAL

■ 14 Gauge - Category 4



IC Find #	Part No.	Description	mm	mm	Thread /mm	Tub qty
670X	T17HXTG14050C4X	14-10 x 50	Hex 3/8	35	37	500
674X	T17HXTG14065C4X	14-10 x 65	Hex 3/8	35	52	500
524X*	T17HXTG14075C4X	14-10 x 75	Hex 3/8	35	52	400

*Part No. T17HXTG14075C4X is suitable for cyclonic applications subject to letter of opinion from FYFE Consulting Engineers (Ref. 51176-5). This part is not referenced in the NT Deemed to comply manual (DTCM).

EXTREME WEATHER SCREW ASSEMBLY

CYCLONIX®

**APPROVED AND
REFERENCED IN THE
NT DEEMED TO COMPLY
MANUAL (DTCM)**

ICCONS® range of Cyclonix® Screws have been specially engineered and proven suitable for Australia's most severe cyclonic regions.

All screws have undergone extensive and fully independent testing by The University of Adelaide (ENGTEST) and shown to meet or exceed all current relevant Australian Standards for both strength and serviceability.

CYCLONIX® Deks Washer Assembly Material.

80 Shore Hardness Non - Conductive EPDM compound. In compliance with Bluescope™ Steel Technical Bulletin TB16 for Fasteners.

SDS and Type 17 Hex 3/8 Head with Top Shank Protection Teeth

One piece washer assembly for both Corrugated and Square Rib Roofing Sheet Profiles

- ★ EPDM bonnet designed to suit the under-head profile of the Cyclonix® screw.
- ★ Aluminium Series 5000 pressure plate for high tensile and yield strengths.
- ★ Tapered Angle prevents washer spew.
- ★ Inner ring seals against screw shank.
- ★ Deep inner sealing ring for additional watertight security.
- ★ Thick outer seal provides a secure seal against all profiles.

**6 Star EPDM Sealing Washer
and Pressure Plate design
for optimum water tightness
and security**

Independently Tested and conforming to all current relevant Australian Standards



NAUTILUS®
EXTEND 4



Type 17 Hex Head Top Grip

■ 12 Gauge - EPDM Sealing Washer - Coarse Thread - Category 4



IC4 EXTERNAL With Sealing Washer



IC Find #	Part No.	Description	mm	mm	Thread /mm	qty	qty
546W*	T17HXTG1250C4W	12-11 x 50	Hex 5/16	30	Full	1000	1000
548W*	T17HXTG1265C4W	12-11 x 65	Hex 5/16	30	Full	1000	1000

* Available in TRADE PACK see page 164



■ 14 Gauge - EPDM Sealing Washer - Coarse Thread - Category 4



680W	T17HXTG14175C4W	14-10 x 175	Hex 3/8	35	75	250	250
------	-----------------	-------------	---------	----	----	-----	-----



■ 14 Gauge with DEKFAST® Multiseal™ Washer - Category 4



680DFW	T17HXTG14175C4DFW	14-10 x 175	Hex 3/8	35	75	TBA	TBA
--------	-------------------	-------------	---------	----	----	-----	-----

Influencing the Industry

www.iccons.com.au



TYPE 17 SCREWS



Type 17 Wafer Head

■ 10 Gauge - Coarse Thread - Zinc Yellow

■ 10 Gauge - Coarse Thread - Category 3



ZINC

INTERNAL

IC3

EXTERNAL



IC Find #	Part No.	IC Find #	Part No.	Description	mm	mm	Thread /mm	qty	qty
566	T17WA1025ZY	560*	T17WA1025C3	10-12 x 25	Wafer / PH2	23	Full	1000	4000
568	T17WA1035ZY	562*	T17WA1035C3	10-12 x 35	Wafer / PH2	25	Full	1000	3000
570	T17WA1045ZY	564	T17WA1045C3	10-12 x 45	Wafer / PH2	25	30	500	2000

* Available in TRADE PACK see page 164



Type 17 CSK Head

■ 6 Gauge - Coarse Thread - Zinc Yellow

ZINC

INTERNAL



IC Find #	Part No.	IC Find #	Part No.	Description	mm	mm	Thread /mm	qty	qty
592*	T17CS0625ZY			6-18 x 25	CSK / PH2	16	Full	1000	8000



■ 8 Gauge - Coarse Thread - Zinc Yellow

596	T17CS0820ZY			8-15 x 20	CSK / PH2	18	Full	1000	8000
598*	T17CS0825ZY			8-15 x 25	CSK / PH2	18	Full	1000	6000



■ 10 Gauge - Coarse Thread - Zinc Yellow

■ 10 Gauge - Coarse Thread - Category 3



602*	T17CS1030ZY			10-12 x 30	CSK / PH2	25	Full	1000	4000
604*	T17CS1040ZY	612*	T17CS1040C3	10-12 x 40	CSK / PH2	25	Full	1000	3000
606*	T17CS1050ZY	614*	T17CS1050C3	10-12 x 50	CSK / PH2	25	36	500	2000
608*	T17CS1075ZY			10-12 x 75	CSK / PH2	25	50	1000	1000

* Available in TRADE PACK see page 166



Type 17 Bugle Batten

■ 14 Gauge - Coarse Thread - Zinc Yellow

■ 14 Gauge - Coarse Thread - Category 3



ZINC INTERNAL		IC3 EXTERNAL		mm		mm		Thread /mm		qty	
IC Find #	Part No.	IC Find #	Part No.	Description	mm	mm	Thread /mm	qty	qty		
585	T17BB14050ZY	572*	T17BB14050C3	14-10 x 50	Bugle / 5mm Int	30	30	1000	1000		
586*	T17BB14075ZY	574*	T17BB14075C3	14-10 x 75	Bugle / 5mm Int	35	50	1000	1000		
588*	T17BB14100ZY	576*	T17BB14100C3	14-10 x 100	Bugle / 5mm Int	35	65	500	500		
		578	T17BB14125C3	14-10 x 125	Bugle / 5mm Int	35	85	250	250		
		580	T17BB14150C3	14-10 x 150	Bugle / 5mm Int	35	100	250	250		
		590	T17BB14200C3	14-10 x 200	Bugle / 5mm Int	35	100	250	250		

* Available in TRADE PACK see page 165

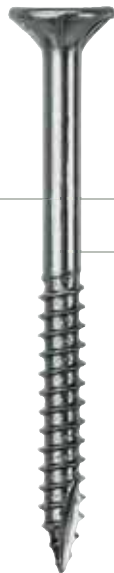

Type 17 Bugle Batten 302 & 316 Stainless Steel

■ 14 Gauge - Coarse Thread - 302 (A2) Stainless Steel

■ 14 Gauge - Coarse Thread - 316 (A4) Stainless Steel

Now In TUBS!



302 SS EXTERNAL		316 SS EXTERNAL		mm		mm		Thread /mm		qty	
IC Find #	Part No.	IC Find #	Part No.	Description	mm	mm	Thread /mm	qty	qty		
573	T17BB14050SS			14-10 x 50	Bugle / 5mm Int	30	30	1000	1000		
582*	T17BB14075SS	581	T17BB14075SS-316	14-10 x 75	Bugle / 5mm Int	35	50	1000	1000		
584*	T17BB14100SS			14-10 x 100	Bugle / 5mm Int	35	65	500	500		
		583	T17BB14100SS-316	14-10 x 100	Bugle / 5mm Int	35	65	800	800		

* Available in TRADE PACK see page 164 Also referenced on Page 139



speedekz™

Self Drilling SPEEDEKZ™ for Timber

12 Gauge - Coarse Thread 316 (A4) Stainless Steel

- Marine Grade 316 Stainless Steel.
- Aesthetic countersunk self-embedding head.
- No pre-drilling.
- Square Drive for positive non wobble installs.
- No splitting even at end grain.
- Unique "no squeak" ring clamp thread design.
- Suitable hardwood and softwood.



316 SS EXTERNAL

DRIVER BIT INCLUDED



IC Find #	Part No.	Description	mm	mm	Thread /mm	qty	qty
620	SDEK12050SS-250	12g x 50	CSK / No.2 Sqr	25	Full	250	1500
622	SDEK12065SS-500	12g x 65	CSK / No.2 Sqr	25	Full	250	1500

Note: Pre drilling may be required for some hardwood

Self Drilling SPEEDEKZ™ GP for Timber

10 Gauge - Coarse Thread 304 (A2) Stainless Steel



304 SS EXTERNAL

DRIVER BIT INCLUDED



IC Find #	Part No.	Description	Torx	mm	Thread /mm	qty	qty
646	SDEKGP10050SS	10g x 50mm	T20	25	35	250	1500
648	SDEKGP10065SS	10g x 65mm	T20	25	35	250	1500

Note: Pre drilling may be required for some hardwood

Knife Thread CSK Decking Screw

10 Gauge - Coarse Thread 304 (A2) Stainless Steel.

Square-knifed threads and one special ring - reduces Drive-in torque by a minimum of 20% compared to standard deck screws, and install time is reduced by Min of 20% compared to Standard deck screws



304 SS EXTERNAL

DRIVER BIT INCLUDED



IC Find #	Part No.	Description	mm	mm	Thread /mm	qty	qty
634*	T17DK10050KTSS	10-8 x 50	CSK / No.2 Sqr	25	34	250	1500
636*	T17DK10065KTSS	10-8 x 65	CSK / No.2 Sqr	25	44	150	900

* Available in TRADE PACK see page 165 Note: Pre drilling may be required for some hardwood



General Purpose CSK Decking Screw

■ 10 Gauge - Coarse Thread 304 (A2) Stainless Steel.



304 SS EXTERNAL

THE ORIGINAL ROBERTSON DRIVER BIT INCLUDED



IC Find #	Part No.	Description	mm	mm	Thread /mm	qty	qty
642	T17DK10050SS	10-8 x 50	CSK / No.2 Sqr	25	34	250	1500
644	T17DK10065SS	10-8 x 65	CSK / No.2 Sqr	25	44	250	1500

Note: Pre drilling may be required for some hardwood

Trim Head Decking Screw

■ 9 Gauge - Coarse Thread 304 (A2) Stainless Steel



304 SS EXTERNAL

THE ORIGINAL ROBERTSON DRIVER BIT INCLUDED



IC Find #	Part No.	Description	mm	mm	Thread /mm	qty	qty
626*	T17TH09053SS	9-9 x 53	CSK / No.2 Sqr	25	38	250	1500



■ 9 Gauge - Coarse Thread - Category 4



IC4 EXTERNAL

DRIVER BIT INCLUDED



IC Find #	Part No.	Description	mm	mm	Thread /mm	qty	qty
630*	T17TH09053TP	9-9 x 53	CSK / No.2 Sqr	25	38	250	1500

* Available in TRADE PACK see page 166 Note: Pre drilling may be required for some hardwood

Countersink Tool For Timber



The BETTER-Bit Pre-drilling and Countersinking Tool is designed for decking and general woodworking. Features adjustable countersink, Dual function stop collar with engineered "O" ring to protect the work surface, and replaceable long-life drill bits that cut through decking more than twice as fast as standard wood bits.

Features:

- DUAL ACTION TWIN LOW FRICTION SPIN BEARINGS
- SUITABLE FOR IMPACT DRIVERS OR DRILL DRIVERS
- ENGINEERED "O"RING TO PROTECT THE WORK SURFACE
- ADJUSTING COLLET FOR VARIOUS COUNTERSINK DEPTHS



NEW



Replacement bits



Suitable ICCONS Screws



Part No.	Part No.	Description	gauge	IC Find #	qty	qty
TBB08G-12G		Countersinking Tool for 8g - 12g screws	8g to 12g	620, 622, 626, 630, 634, 636, 642, 644 & 650	10	n/a
	TBB08G-12G-RB	5 Piece replacement bits			50 sets	200 sets
TBB14G		Countersinking Tool for 14g screws	14G	Bugle Batten screws 572 through to 590	10	n/a
	TBB14G-RB	4 Piece replacement bits			50 sets	200 sets



THE BETTER BIT

THE SMARTER SOLUTION

THE BETTER BIT

GREAT FOR

- **DECKING**
- **WOOD WORK**
- **COMPOSITE**
- **ADJUSTABLE COUNTERSUNK**



PROBLEM



PROBLEM SOLVED



1/4" HEX SUITABLE FOR IMPACT DRIVERS OR DRILL DRIVERS

DUAL ACTION TWIN LOW FRICTION SPIN BEARINGS

LOCKING DEPTH ADJUSTING COLLET FOR VARIOUS COUNTERSINK DEPTHS, SUITS 8g, 10g, & 12g screws

DUAL FUNCTION ROTATING STOP COLLAR WITH ENGINEERED "O" RING TO PREVENT SURFACE MARKS

3 X LONG-LIFE COUNTERSINKING BLADES

HEX KEY TOOL & REPLACEABLE PILOT BITS

NEW



10 Piece Counter Display

The Better Bit



THE BETTER BIT

Countersink Tool For Timber

NEW

The BETTER-Bit Pre-drilling and Countersinking Tool is designed for decking and general woodworking. Features adjustable countersink, Dual function stop collar with engineered "O" ring to protect the work surface, and replaceable long-life drill bits that cut through decking more than twice as fast as standard wood bits.



Features:

- DUAL ACTION TWIN LOW FRICTION SPIN BEARINGS
- SUITABLE FOR IMPACT DRIVERS OR DRILL DRIVERS
- ENGINEERED "O"RING TO PROTECT THE WORK SURFACE
- ADJUSTING COLLET FOR VARIOUS COUNTERSINK DEPTHS

Part No.	Part No.	Description	guage	IC Find #	qty	qty
TBB08G-12G		Countersinking Tool for 8g - 12g screws	8g to 12g	620, 622, 626, 630, 634, 636, 642, 644 & 650	10	n/a
	TBB08G-12G-RB	5 Piece replacement bits / set			1 sets	50 sets
TBB14G		Countersinking Tool for 14g screws	14G	Bugle Batten screws 572 through to 590	10	n/a
	TBB14G-RB	4 Piece replacement bits / set			1 set	50 sets

Smart-Bit Countersink Tool For Timber & Fibre Cement Board

The Smart-Bit® Pre-drilling and Countersinking Tool is designed for decking and general woodworking. Features a pre-set countersink, a free spinning stop collar to protect the work surface, and replaceable Powerbolic® fluted drill bits that cut through decking more than twice as fast as standard wood bits.



SBFC10G

Features:

- Free-Spinning Stop Collar with O-ring
- Anti-Clog Debris Cavity
- Powerbolic® High-Speed Drill Bit
- Pre-set Countersink

Part No.	Part No.	Description	mm	guage	IC Find #	qty	qty
SB07G		7 Gauge include spare drill bits	3.0	7	626, 630, 650	1	6
SB08G		8 Gauge include spare drill bits	3.2	8		1	6
SB10G		10 Gauge include spare drill bits	3.6	10	634, 636, 642, 644	1	6
SB12G		12 Gauge include spare drill bits	4.0	12		1	6
SB14G		14 Gauge include spare drill bits	4.8	14	Bugle Battens	1	6
	SBFC10G	Fibre cement 10 Gauge includes 2x replacement drill bits	6.2	10		1	6



Smart-Bit Countersink Tool Replacement Drill Bits

Part No.	Description	mm	guage	qty	qty
SB07GRP	7 Gauge drill bits - 5pce pack	3.0	7	1	4
SB08GRP	8 Gauge drill bits - 5pce pack	3.2	8	1	4
SB10GRP	10 Gauge drill bits - 5pce pack	3.6	10	1	4
SB12GRP	12 Gauge drill bits - 5pce pack	4.0	12	1	4
SB14GRP-40	14 Gauge drill bits - 5pce pack 40mm long	4.8	14	1	4
SB14GRP-75	14 Gauge drill bits - 5pce pack 75mmlong	4.8	14	1	4



Needle Point Bugle Head Fine Thread



■ 6 Gauge - Fine Thread for Fixing Plasterboard to steel

ZINC INTERNAL



IC Find #	Part No.	Description	mm	mm	Thread /mm	qty	qty
700	NPBUF0620ZY	6-18 x 20	PH2	0.5 - 0.75	Full	1000	8000
702*	NPBUF0625ZY	6-18 x 25	PH2	0.5 - 0.75	Full	1000	8000
704*	NPBUF0632ZY	6-18 x 32	PH2	0.5 - 0.75	Full	1000	6000
706	NPBUF0635ZY	6-18 x 35	PH2	0.5 - 0.75	Full	500	6000
708*	NPBUF0641ZY	6-18 x 41	PH2	0.5 - 0.75	Full	1000	4000
710*	NPBUF0645ZY	6-18 x 45	PH2	0.5 - 0.75	Full	1000	3000

* Available in TRADE PACK see page 167



■ 7 Gauge - Fine Thread for Fixing Plasterboard to steel

IC Find #	Part No.	Description	mm	mm	Thread /mm	qty	qty
714	NPBUF0725ZY	7-15 x 25	PH2	0.5 - 0.75	Full	1000	8000
716	NPBUF0732ZY	7-15 x 32	PH2	0.5 - 0.75	Full	1000	6000
718	NPBUF0745ZY	7-15 x 45	PH2	0.5 - 0.75	Full	1000	4000
720*	NPBUF0750ZY	7-15 x 50	PH2	0.5 - 0.75	Full	500	2000
722*	NPBUF0757ZY	7-15 x 57	PH2	0.5 - 0.75	50	500	1500

* Available in TRADE PACK see page 167



■ 8 Gauge - Fine Thread for Fixing Plasterboard to steel

IC Find #	Part No.	Description	mm	mm	Thread /mm	qty	qty
726*	NPBUF0865ZY	8-15 x 65	PH2	0.5 - 0.75	50	500	1500
728*	NPBUF0875ZY	8-15 x 75	PH2	0.5 - 0.75	50	250	750

* Available in TRADE PACK see page 167



■ 10 Gauge - Fine Thread for Fixing Plasterboard to steel

IC Find #	Part No.	Description	mm	mm	Thread /mm	qty	qty
736	NPBUF1010OZY	10-12 x 100	PH2	0.5 - 0.75	65	250	750

Needle Point Bugle Head Fine Thread Collated



■ 6 Gauge - Fine Thread Collated for Fixing Plasterboard to steel



ZINC INTERNAL



IC Find #	Part No.	Description	mm	mm	Thread /mm	qty	qty
702C	NPBUF0625ZYCOL	6-18 x 25	PH2	0.5 - 0.75	Full	1000	10 000
704C	NPBUF0632ZYCOL	6-18 x 32	PH2	0.5 - 0.75	Full	1000	10 000
708C	NPBUF0641ZYCOL	6-18 x 41	PH2	0.5 - 0.75	Full	1000	10 000

See page 156 for full collated offering



Needle Point Bugle Head Coarse Thread

■ 7 Gauge - Coarse Thread for Fixing Plasterboard to Timber

ZINC

INTERNAL



IC Find #	Part No.	Description	mm	mm	Thread /mm	qty	qty
770	NPBUC0720ZY	7-9 x 20	PH2	16	Full	1000	8000
772	NPBUC0725ZY	7-9 x 25	PH2	18	Full	1000	8000
774	NPBUC0732ZY	7-9 x 32	PH2	18	Full	1000	6000



■ 8 Gauge - Coarse Thread for Fixing Plasterboard to Timber

778	NPBUC0845ZY	8-9 x 45	PH2	20	Full	1000	3000
780	NPBUC0850ZY	8-9 x 50	PH2	20	Full	500	2000
782	NPBUC0875ZY	8-9 x 75	PH2	20	50	400	1200



■ 10 Gauge - Coarse Thread for Laminating multiple layers of plasterboard

786	NPBUC1038ZY	10-8 x 38	PH2	20	Full	500	2000
788	NPBUC1050ZY	10-8 x 50	PH2	20	Full	500	1500



NEW

■ 10 Gauge - Coarse Thread for Fixing Plasterboard to timber / Laminating multiple layers of Plasterboard



786C	NPBUC1038ZYCOL	10-8 x 38	PH2	20	Full	500	5 000
------	----------------	-----------	-----	----	------	-----	-------



Needle Point Bugle Head Coarse Thread Collated

■ 6 Gauge - Coarse Thread for Fixing Plasterboard to Timber

ZINC

INTERNAL



IC Find #	Part No.	Description	mm	mm	Thread /mm	qty	qty
744C	NPBUC0625ZYCOL	6-9 x 25	PH2	18	Full	1000	10 000
746C	NPBUC0632ZYCOL	6-9 x 32	PH2	18	Full	1000	10 000
748C	NPBUC0641ZYCOL	6-9 x 41	PH2	18	Full	1000	10 000

See page 156 for full collated offering



Needle Point CSK Head Villaboard® 4 Nibb

■ 8 Gauge - Self Embedding Head

ZINC

INTERNAL



IC Find #	Part No.	Description	mm	mm	Thread /mm	qty	qty
796*	NPCSSE0820ZY	8-15 x 20	PH2	0.5 - 0.75	Full	1000	8000
798*	NPCSSE0830ZY	8-15 x 30	PH2	0.5 - 0.75	Full	1000	6000

* Available in TRADE PACK see page 147



NEEDLE POINT SCREWS



Needle Point CSK Head Villaboard® 4 Nibb Collated

■ 8 Gauge - Self Embedding Head



ZINC INTERNAL



IC Find #	Part No.	Description	mm	mm	Thread /mm	qty	qty
796C	NPCSSE0820ZYCOL	8-15 x 20	PH2	0.5 - 0.75	Full	1000	10 000
798C	NPCSSE0830ZYCOL	8-15 x 30	PH2	0.5 - 0.75	Full	1000	10 000

See page 156 for full collated offering

Needle Point Flathead

■ 10 Gauge - Zinc Yellow

■ 10 Gauge - Category 3

NAUTILUS® 3



ZINC INTERNAL

IC3 EXTERNAL



IC Find #	Part No.	IC Find #	Part No.	Description	mm	mm	Thread /mm	qty	qty
754*	NPFH1016ZY	760*	NPFH1016C3	10-15 x16	Wafer / PH2	0.55 - 1.20	Full	1000	8000

* Available in TRADE PACK see page 167



Needle Point Steel Frame

■ Pancake Head Steel Frame Fixing - Category 3

NEW

NAUTILUS® 3

IC3 EXTERNAL



IC Find #	Part No.	Description	mm	mm	Thread /mm	qty	qty
766	NPSFTM0615C3	M6 x 15mm Pancake Head Steel Frame Fixing	Flat / PH3	(2x) 0.55 Up to (2x) 1.00		1000	4000

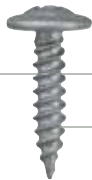

Needle Point Button Head

■ 8 Gauge - Zinc Yellow

■ 8 Gauge - Category 3

NAUTILUS® 3

ZINC INTERNAL

IC3 EXTERNAL



IC Find #	Part No.	IC Find #	Part No.	Description	mm	mm	Thread /mm	qty	qty
800*	NPBH0812ZY			8-15 x 12	PH2	0.5 - 0.75	Full	1000	8000
802*	NPBH0815ZY			8-15 x 15	PH2	0.5 - 0.75	Full	1000	6000
804*	NPBH0820ZY	812	NPBH0820C3	8-15 x 20	PH2	0.5 - 0.75	Full	1000	6000
806*	NPBH0825ZY	814	NPBH0825C3	8-15 x 25	PH2	0.5 - 0.75	Full	1000	4000
808*	NPBH0832ZY	816	NPBH0832C3	8-15 x 32	PH2	0.5 - 0.75	Full	1000	3000

* Available in TRADE PACK see page 168



Needle Point Hex Head



■ 8 Gauge - Category 4

■ 8 Gauge - EPDM Sealing Washer - Category 4



IC4

EXTERNAL

IC4

EXTERNAL
With sealing Washer

IC Find #	Part No.	IC Find #	Part No.	Description	mm	mm	thread /mm	qty	qty
820*	NPHXC0812C4	820W	NPHXC0812C4W	8-15 x 12	Hex 1/4	0.5 - 0.75	Full	1000	8000



■ 10 Gauge - Coarse Thread - Category 4

■ 10 Gauge - EPDM Sealing Washer - Category 4



824*	NPHXC1020C4	824W*	NPHXC1020C4W	10-12 x 20	Hex 5/16	0.5 - 0.75	Full	1000	4000
------	-------------	-------	--------------	------------	----------	------------	------	------	------

* Available in TRADE PACK see page 168

Needle Point Pan Head



■ 6 Gauge - Zinc Yellow

ZINC

INTERNAL

IC Find #	Part No.	Description	mm	mm	Thread /mm	qty	qty
828	NPPH0620ZY	6-15 x 20	PH2	0.5 - 0.75	Full	1000	8000



830	NPPH0712ZY	7-16 x 12	PH2	0.5 - 0.75	Full	1000	8000
832*	NPPH0720ZY	7-16 x 20	PH2	0.5 - 0.75	Full	1000	8000
834	NPPH0725ZY	7-16 x 25	PH2	0.5 - 0.75	Full	1000	6000
836	NPPH0730ZY	7-16 x 30	PH2	0.5 - 0.75	Full	1000	6000
838	NPPH0740ZY	7-16 x 40	PH2	0.5 - 0.75	Full	1000	4000
840	NPPH0750ZY	7-16 x 50	PH2	0.5 - 0.75	Full	500	2000

* Available in TRADE PACK see page 168



Needle Point Slotted Hex Head

■ 8 Gauge - Zinc Yellow

□ 8 Gauge - Zinc Clear

ZINC

INTERNAL

ZINC

INTERNAL

IC Find #	Part No.	IC Find #	Part No.	Description	mm	mm	thread /mm	qty	qty
850	NPHXS0832ZY	852	NPHXS0832ZC	8-15 x 32	Hex 1/4	0.5 - 0.75	Full	1000	4000



CHIPBOARD SCREWS

Chipboard - 6 Nibb

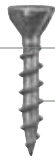

■ 8 Gauge - Zinc Yellow

■ 8 Gauge - Category 3

NAUTILUS® 3

ZINC

INTERNAL

IC3

EXTERNAL



IC Find #	Part No.	IC Find #	Part No.	Description	mm	mm	thread /mm	qty	qty
020*	CBSE0820ZY	060*	CBSE0820C3	8-9 x 20	CSK / PH2	18	Full	1000	8000
022*	CBSE0825ZY	062*	CBSE0825C3	8-9 x 25	CSK / PH2	18	Full	1000	6000
024*	CBSE0828ZY	064*	CBSE0828C3	8-9 x 28	CSK / PH2	18	19	1000	6000
026*	CBSE0832ZY	066*	CBSE0832C3	8-9 x 32	CSK / PH2	18	21	1000	4000
028*	CBSE0835ZY	068*	CBSE0835C3	8-9 x 35	CSK / PH2	18	23	1000	4000
030*	CBSE0840ZY	070*	CBSE0840C3	8-9 x 40	CSK / PH2	18	27	1000	4000
032*	CBSE0845ZY	072*	CBSE0845C3	8-9 x 45	CSK / PH2	18	30	1000	3000
040*	CBSE0850ZY	074*	CBSE0850C3	8-9 x 50	CSK / PH2	18	33	1000	3000
042*	CBSE0857ZY	076*	CBSE0857C3	8-9 x 57	CSK / PH2	18	38	500	1500

* Available in TRADE PACK see page 169

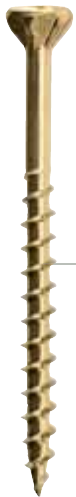

■ 10 Gauge - Zinc Yellow

■ 10 Gauge - Category 3

NAUTILUS® 3

050*	CBSE10065ZY	080*	CBSE10065C3	10-8 x 65	CSK / PH2	25	43	500	1500
052*	CBSE10075ZY	082*	CBSE10075C3	10-8 x 75	CSK / PH2	25	50	250	1050
054*	CBSE10100ZY	084*	CBSE10100C3	10-8 x 100	CSK / PH2	25	67	250	750
056	CBSE10125ZY			10-8 x 125	CSK / PH2	25	83	250	750
058	CBSE10150ZY			10-8 x 150	CSK / PH2	25	110	150	750

* Available in TRADE PACK see page 169

Follow Us



Facebook
ICCONS Pty Ltd



Instagram
iccons.ptyltd



LinkedIn
ICCONS Pty Ltd

Blind Rivets

■ Scell-it® ■



|Quality European design|

ICCONS® Rivets are packed in high strength sturdy cardboard boxes displaying clear concise labelling.

To further protect the Rivets they are contained in heavy duty transparent waterproof bags.



ICCONS® in partnership with Scell-it® is proud to release our new range of Blind Rivets!

Focused on advanced design, high grade alloy metals, precise manufacturing and total quality control, you can be assured that the ICCONS® range of blind rivets are of the highest European design and quality.

As with our screw range, ICCONS® also offers its rivets in high quality paint finishes covering all major Colorbond® colours.

**See Pages 100 To 107
For Full Rivet And Tooling Range.**





Self Drilling Bugle Head

■ 6 Gauge - Collated Strip - Zinc Yellow

ZINC INTERNAL



IC Find #	Part No.	Description	mm	mm	Thread /mm	qty	qty
292C	SDBU0625ZYCOL	6-20 x 25	Bugle / PH2	0.75 - 2.30	Full	1000	10 000
294C	SDBU0632ZYCOL	6-20 x 32	Bugle / PH2	0.75 - 2.30	Full	1000	10 000
296C	SDBU0641ZYCOL	6-20 x 41	Bugle / PH2	0.75 - 2.30	Full	1000	10 000



Self Drilling Flathead

■ 10 Gauge - Collated - Coarse Thread - Zinc Yellow

ZINC INTERNAL



IC Find #	Part No.	Description	mm	mm	Thread /mm	qty	qty
256C	SDFHC1022ZYCOL	10-16 x 22	Flat / PH2	0.75 - 3.00	Full	1000	10,000



Self Drilling CSK Head Villaboard® 4 Nibb

■ 8 Gauge - Self Embed Head Collated - Zinc Yellow

ZINC INTERNAL



IC Find #	Part No.	Description	mm	mm	Thread /mm	qty	qty
344C	SDCSSE0820ZYCOL	8-15 x 20	PH2	0.75 - 2.30	Full	1000	10 000
346C	SDCSSE0830ZYCOL	8-15 x 30	PH2	0.75 - 2.30	Full	1000	10 000



Self Drilling For Fibre Cement to 0.75 -2.5mm steel

■ 8 Gauge - Self Embed Head Collated - C3

FIBRE-STAR®



IC3 INTERNAL / EXTERNAL



IC Find #	Part No.	Description	mm	mm	Thread /mm	qty	qty
433C	SDFLSE0825GC3COL	8-18 x 25	PH2	0.75 - 2.50	Full	1000	2000



Needle Point CSK Head Villaboard® 4 Nibb

■ 8 Gauge - Self Embedding Head

ZINC INTERNAL



IC Find #	Part No.	Description	mm	mm	Thread /mm	qty	qty
796C	NPCSSE0820ZYCOL	8-15 x 20	PH2	0.5 - 0.75	Full	1000	10 000
798C	NPCSSE0830ZYCOL	8-15 x 30	PH2	0.5 - 0.75	Full	1000	10 000



Now With a 5.0Ah Battery

18V | 5.0Ah quick charge lithium batteries
1.1Kg - the lightest on the market



LITHIUM
Long Life - ION

for Full Specs see page195



4000 pce trade box



ZINC INTERNAL

Needle Point Bugle Head Fine Thread

6 Gauge - Fine Thread Collated for Fixing Plasterboard to steel



IC Find #	Part No.	Description	mm	mm	Thread /mm	qty	qty
702C	NPBUF0625ZYCOL	6-18 x 25	PH2	0.5 - 0.75	Full	1000	10 000
702CT	NPBUF0625ZYCOL-T	6-18 x 25 Trade Box	PH2	0.5 - 0.75	Full	4000	Na
704C	NPBUF0632ZYCOL	6-18 x 32	PH2	0.5 - 0.75	Full	1000	10 000
708C	NPBUF0641ZYCOL	6-18 x 41	PH2	0.5 - 0.75	Full	1000	10 000



ZINC INTERNAL

Needle Point Bugle Head Coarse Thread

6 Gauge - Coarse Thread for Fixing Plasterboard to timber



IC Find #	Part No.	Description	mm	mm	Thread /mm	qty	qty
744C	NPBUC0625ZYCOL	6-9 x 25	PH2	18	Full	1000	10 000
744CT	NPBUC0625ZYCOL-T	6-9 x 25 Trade Box	PH2	18	Full	4000	n/a
746C	NPBUC0632ZYCOL	6-9 x 32	PH2	18	Full	1000	10 000
746CT	NPBUC0632ZYCOL-T	6-9 x 32 Trade Box	PH2	18	Full	4000	n/a
748C	NPBUC0641ZYCOL	6-9 x 41	PH2	18	Full	1000	10 000



NEW

10 Gauge - Coarse Thread for Fixing Plasterboard to timber / Laminating multiple layers of Plasterboard

786C	NPBUC1038ZYCOL	10-8 x 38	PH2	20	Full	500	5000
------	----------------	-----------	-----	----	------	-----	------



Self Drilling Hex Head - Coarse

■ 10 & 12 Gauge - Category 4

■ 10, 12, 14 Gauge - EPDM Sealing Washer - Category 4

NAUTILUS 4



Part No	Trade Pack	Part No	Trade Pack	Description	mm	mm	thread /mm	qty	qty - packs
TP104	Trade Pack	TP104W	Trade Pack	10-16x 16	Hex 5/16	0.75-3.50	Full	100	20
TP106	Trade Pack	TP106W	Trade Pack	10-16 x 25	Hex 5/16	0.75-3.50	Full	100	20
TP110	Trade Pack	TP110W	Trade Pack	12-14 x 20	Hex 5/16	1.00-4.50	Full	50	20
TP111	Trade Pack			12-14 x 30	Hex 5/16	1.00-4.50	Full	50	20
		TP116W	Trade Pack	12-14 x 55	Hex 5/16	1.00-4.50	42	20	20
		TP118W	Trade Pack	12-14 x 65	Hex 5/16	1.00-5.00	50	20	20
TP124	Trade Pack	TP124W	Trade Pack	14-10 x 25	Hex 3/8	1.00-5.00	Full	20	20
TP126	Trade Pack	TP126W	Trade Pack	14-10 x 42	Hex 3/8	1.00-5.00	Full	20	20
		TP128W	Trade Pack	14-10 x 50	Hex 3/8	1.00-5.00	Full	20	20
		TP130W	Trade Pack	14-10 x 65	Hex 3/8	1.00-5.00	50	20	20
		TP132W	Trade Pack	14-10 x 75	Hex 3/8	1.00-5.00	62	20	20
		TP134W	Trade Pack	14-10 x 95	Hex 3/8	1.00-5.00	81	20	20

Self Drilling Hex Head - Fine Thread

■ 12 Gauge - Fine Thread - Category 4

■ 12 Gauge - EPDM Sealing Washer - Fine Thread - Category 4

NAUTILUS 4



Part No	Trade Pack	Part No	Trade Pack	Description	mm	mm	thread /mm	qty	qty - packs
TP172	Trade Pack	TP172W	Trade Pack	12-24 x 30	Hex 5/16	1.20-4.50	Full	50	20

Self Drilling Hex Head - Fine Thread

■ 14 Gauge - Fine Thread - Category 4

NAUTILUS 4



Part No	Trade Pack	Description	mm	mm	thread /mm	qty	qty - packs
TP176	Trade Pack	14-20 x 25	Hex3/8	1.20-5.00	Full	50	20



Self Drilling Hex Head - Series 5

■ 12 Gauge - Fine Thread - Category 4

■ 12 Gauge - EPDM Sealing Washer - Fine Thread - Category 4

NAUTILUS® 4



IC4

EXTERNAL

IC4

EXTERNAL With Sealing Washer



Part No	Trade Pack	Part No	Trade Pack	Description	mm	mm	thread /mm	qty	qty - packs
TP190	Trade Pack	TP190W	Trade Pack	12-24 x 32	Hex 5/16	3.00-12.00	Full	50	20
TP192	Trade Pack	TP192W	Trade Pack	12-24 x 50	Hex 5/16	3.00-12.00	Full	20	20
TP194	Trade Pack	TP194W	Trade Pack	12-24 x 65	Hex 5/16	3.00-12.00	50	20	20
TP196	Trade Pack			12-24 x 85	Hex 5/16	3.00-12.00	50	20	20



Part No	Trade Tub	Part No	Trade Tub	Description	mm	mm	Thread /mm	qty	qty - packs
TT190	Trade Tub	TT190W	Trade Tub	12-24 x 32	Hex 5/16	3.00-12.00	Full	250	n/a
TT192	Trade Tub	TT192W	Trade Tub	12-24 x 50	Hex 5/16	3.00-12.00	Full	250	n/a
TT194	Trade Tub	TT194W	Trade Tub	12-24 x 65	Hex 5/16	3.00-12.00	50	250	n/a
TT196	Trade Tub	TT196W	Trade Tub	12-24 x 85	Hex 5/16	3.00-12.00	50	250	n/a



Self Drilling Hex Head - Top Grip

NAUTILUS® 4

■ 12 Gauge - with EPDM Sealing Washer - Coarse Thread - Category 4 Self Drilling Hex - top grip roofing screw.



IC4

EXTERNAL With Sealing Washer



Part No.	Trade Pack	Description	mm	mm	Thread /mm	qty	qty - packs
TP156W	Trade Pack	12-14 x 42	Hex 5/16	1.00 - 4.50	Full	20	20
TP158W	Trade Pack	12-14 x 53	Hex 5/16	1.00 - 4.50	Full	20	20



Part No	Trade Tub	Description	mm	mm	Thread /mm	qty	qty - packs
TT156W	Trade Tub	12-14 x 42	Hex 5/16	1.00 - 4.50	Full	250	n/a
TT158W	Trade Tub	12-14 x 53	Hex 5/16	1.00 - 4.50	Full	250	n/a

SELF DRILLING



Batten-Stars®

NAUTILUS® 3

■ 12 Gauge - Metal Top Hat Batten to Steel or Timber - Category 3 Self-drilling universal screw for fastening metal roofing battens to steel purlins up to 1.9mm or to timber roof trusses.



IC3 EXTERNAL



Part No.	Description	mm	mm	Thread /mm	qty / Tub	qty - packs	
TT160	Trade Tub	12-11 x 40	Hex 5/16	0.55 - 1.90	Full	100	n/a



Roof-Stars®

NAUTILUS® 4

■ 13 Gauge - Metal Roof Sheet to Steel or Timber Battens - Category 4

Self-drilling universal roofing screw with sealing washer for fastening metal roof sheet to thin metal battens, steel purlins or alternatively can be used to fasten to timber battens.



IC4 EXTERNAL With Sealing Washer



Part No.	Description	mm	mm	Thread /mm	qty	qty - packs	
TP162W	Trade Pack	13-11 X 50	Hex 5/16	0.55 - 1.90	33	20	20



TT162W	Trade Tub	13-11 X 50	Hex 5/16	0.55 - 1.90	33	100	n/a
--------	-----------	------------	----------	-------------	----	-----	-----



Wall-Stars®

NAUTILUS® 4

■ 13 Gauge - thin metal battens, steel purlins - Category 4

Self Drilling universal cladding screw for fastening cladding to thin metal battens, steel purlins or alternatively can be used to fasten to timber battens.



IC4 EXTERNAL With Sealing Washer



Part No.	Description	mm	mm	Thread /mm	qty	qty - packs	
TT166W	Trade Tub	13-11 X 25	Hex 5/16	0.55 - 1.90	Full	100	n/a



Self Drilling Button Head



■ 8 Gauge - Coarse Thread - Zinc Yellow

■ 8 Gauge - Coarse Thread - Category 3

NAUTILUS® 3

ZINC INTERNAL

IC3 EXTERNAL



Part No.	Description	IC Find #	Part No.	Description	mm	mm	Thread /mm	qty	qty - packs
TP240	Trade Pack	TP230	Trade Pack	8-18 x 12	Button / PH2	0.75 - 2.50	Full	100	20
TP242	Trade Pack	TP232	Trade Pack	8-18 x 16	Button / PH2	0.75 - 2.50	Full	100	20
TP244	Trade Pack	TP234	Trade Pack	8-18 x 20	Button / PH2	0.75 - 2.50	Full	100	20
TP246	Trade Pack	TP236	Trade Pack	8-18 x 25	Button / PH2	0.75 - 2.50	Full	100	20
TP248	Trade Pack	TP238	Trade Pack	8-18 x 32	Button / PH2	0.75 - 2.50	Full	100	20



IC3 EXTERNAL



Self Drilling Wafer Head



■ 10 Gauge - Coarse Thread - Category 3 NAUTILUS® 3



Part No.	Description	mm	mm	Thread /mm	qty	qty - packs
TP200	Trade Pack	10-16 x 16	Wafer / PH2	0.75 - 3.50	Full	100 20
TP202	Trade Pack	10-16 x 22	Wafer / PH2	0.75 - 3.50	Full	100 20
TP204	Trade Pack	10-16 x 30	Wafer / PH2	0.75 - 3.50	Full	100 20
TP206	Trade Pack	10-16 x 40	Wafer / PH2	0.75 - 3.50	Full	100 20



ZINC INTERNAL



IC3 EXTERNAL



Self Drilling Flathead



■ 10 Gauge - Coarse Thread - Zinc Yellow
■ 10 Gauge - Coarse Thread - Category 3 NAUTILUS® 3



Part No.	Description	mm	mm	Thread /mm	qty	qty - packs		
TP254	Trade Pack	TP260	Trade Pack	10-16 x 16	Flat / PH2	0.75 - 3.00	Full	100 20
		TP262	Trade Pack	10-16 x 22	Flat / PH2	0.75 - 3.00	Full	100 20
		TP264	Trade Pack	10-16 x 30	Flat / PH2	0.75 - 3.00	Full	100 20



IC3 EXTERNAL



Self Drilling CSK Head Wing

■ 8 & 10 Gauge - Coarse Thread - Category 3 NAUTILUS® 3



Part No.	Description	mm	mm	Thread /mm	qty	qty - packs
TP268	Trade Pack	8-18 x 32	CSK / PH2	0.75 - 2.50	Full	50 20
TP272	Trade Pack	10-16 x 40	CSK / PH2	0.75 - 3.50	Full	50 20
TP274	Trade Pack	10-16 x 45	CSK / PH2	0.75 - 3.50	Full	50 20
TP276	Trade Pack	10-16 x 55	CSK / PH2	0.75 - 3.50	Full	50 20
TP278	Trade Pack	10-16 x 75	CSK / PH2	0.75 - 3.50	Full	50 20



ZINC INTERNAL



Self Drilling CSK Head Wing



■ 6 Gauge - Coarse Thread - Zinc Yellow



Part No.	Description	mm	mm	Thread /mm	qty	qty - packs
TP282	Trade Pack	6-20 x 42	CSK / PH2	0.75 - 2.30	Full	50 20



Self Drilling Bugle Head

TRADE PACK

■ 6 Gauge - Zinc Yellow

ZINC INTERNAL



Part No.	Description	mm	mm	Thread /mm	qty	qty - packs
TP292	Trade Pack	6-20 x 25	Bugle / PH2	0.75 - 2.30	Full	100 20
TP294	Trade Pack	6-20 x 32	Bugle / PH2	0.75 - 2.30	Full	100 20
TP298	Trade Pack	6-20 x 45	Bugle / PH2	0.75 - 2.30	Full	50 20



Self Drilling CSK Head Fine Thread

TRADE PACK

■ 10 Gauge - Fine Thread - Zinc Yellow

ZINC INTERNAL



Part No.	Description	mm	mm	Thread /mm	qty	qty - packs
TP304	Trade Pack	10-24 x 30	CSK / PH2	1.20 - 3.50	Full	50 20
TP306	Trade Pack	10-24 x 40	CSK / PH2	1.20 - 3.50	Full	50 20
TP308	Trade Pack	10-24 x 50	CSK / PH2	1.20 - 3.50	Full	50 20
TP310	Trade Pack	10-24 x 65	CSK / PH2	1.20 - 3.50	40	50 20



Self Drilling CSK Head Coarse Thread

TRADE PACK

■ 10 Gauge - Fine Thread - Zinc Yellow

■ 10 Gauge - Coarse Thread - Category 3

NAUTILUS[®] 3

ZINC INTERNAL

IC3 EXTERNAL



Part No.	Description	Part No.	Description	mm	mm	Thread /mm	qty	qty - packs
TP314	Trade Pack	TP320	Trade Pack	10-16 x 30	CSK / PH2	0.75 - 3.50	Full	100 20
TP316	Trade Pack	TP322	Trade Pack	10-16 x 40	CSK / PH2	0.75 - 3.50	Full	100 20



Self Drilling CSK Self Embed Head

■ 8 Gauge - 6 Nibb Self Embed Head - Coarse - Zinc Yellow

■ 8 Gauge - 6 Nibb Self Embed Head - Coarse - Category 3

NAUTILUS[®] 3

ZINC INTERNAL

IC3 EXTERNAL



Part No.	Description	Part No.	Description	mm	mm	Thread /mm	qty	qty - packs
TP326	Trade Pack	TP330	Trade Pack	8-18 x 20	CSK / PH2	0.75 - 2.50	Full	100 20
TP328	Trade Pack	TP332	Trade Pack	8-18 x 30	CSK / PH2	0.75 - 2.50	Full	100 20

SELF DRILLING



Type 17 Hex Head



■ 10, 12, 14 Gauge - Coarse Thread - Category 4

■ 10,12, 14 Gauge - EPDM Sealing Washer - Coarse - Category 4



IC4 EXTERNAL IC4 EXTERNAL With Sealing Washer



Part No.	Trade Pack	Part No.	Trade Pack	Description	mm	mm	Thread /mm	qty	qty - packs
TP500	Trade Pack	TP500W	Trade Pack	10-12 x 25	Hex 5/16	23	Full	100	20
TP504	Trade Pack	TP504W	Trade Pack	12-11 x 25	Hex 5/16	23	Full	50	20
TP506	Trade Pack			12-11 x 35	Hex 5/16	30	Full	50	20
TP508	Trade Pack	TP508W	Trade Pack	12-11 x 40	Hex 5/16	30	Full	50	20
		TP510W	Trade Pack	12-11 x 45	Hex 5/16	30	30	50	20
TP512	Trade Pack			12-11 x 50	Hex 5/16	30	33	50	20
TP514	Trade Pack			12-11 x 65	Hex 5/16	30	43	20	20
TP516	Trade Pack	TP516W	Trade Pack	14-10 x 25	Hex 3/8	23	Full	50	20
				14-10 x 40	Hex 3/8	35	Full	20	20
		TP520W	Trade Pack	14-10 x 50	Hex 3/8	35	33	20	20
		TP522W	Trade Pack	14-10 x 65	Hex 3/8	35	43	20	20
TP524	Trade Pack	TP524W	Trade Pack	14-10 x 75	Hex 3/8	35	50	20	20
		TP526W	Trade Pack	14-10 x 90	Hex 3/8	35	60	25	20
TP528	Trade Pack	TP528W	Trade Pack	14-10 x 100	Hex 3/8	35	60	20	20



TT508	Trade Tub			12-11 x 40	Hex 5/16	30	Full	250	n/a
TT512	Trade Tub			12-11 x 50	Hex 5/16	30	33	250	n/a
TT514	Trade Tub			12-11 x 65	Hex 5/16	30	43	250	n/a
TT520	Trade Tub			14-10 x 50	Hex 3/8	35	33	100	n/a
		TT520W	Trade Tub	14-10 x 50	Hex 3/8	35	33	250	n/a
TT522	Trade Tub			14-10 x 65	Hex 3/8	35	43	100	n/a
		TT522W	Trade Tub	14-10 x 65	Hex 3/8	35	43	250	n/a
TT524	Trade Tub			14-10 x 75	Hex 3/8	35	50	100	n/a
		TT524W	Trade Tub	14-10 x 75	Hex 3/8	35	50	250	n/a
TT526	Trade Tub			14-10 x 90	Hex 3/8	35	60	100	n/a
		TT526W	Trade Tub	14-10 x 90	Hex 3/8	35	60	250	n/a
TT528	Trade Tub			14-10 x 100	Hex 3/8	35	60	100	n/a
TT530	Trade Tub			14-10 x 115	Hex 3/8	35	50	100	n/a
TT532	Trade Tub			14-10 x 125	Hex 3/8	35	60	100	n/a
TT534	Trade Tub			14-10 x 150	Hex 3/8	35	60	100	n/a



Type 17 Hex Head Top Grip



■ 12 Gauge - EPDM Sealing Washer - Coarse - Category 4



IC4

EXTERNAL
With Sealing Washer



Part No.	Description	mm	mm	Thread /mm	qty	qty - packs	
TP546W	Trade Pack	12-11 x 50	Hex 5/16	30	Full	20	20
TP548W	Trade Pack	12-11 x 65	Hex 5/16	30	Full	20	20



Type 17 Wafer Head



■ 10 Gauge - Coarse Thread - Category 3



IC3

EXTERNAL



Part No.	Description	mm	mm	Thread /mm	qty	qty - packs	
TP560	Trade Pack	10-12 x 25	Wafer / PH2	23	Full	50	20
TP562	Trade Pack	10-12 x 35	Wafer / PH2	25	Full	50	20



Type 17 Bugle Batten

■ 14 Gauge - Coarse Thread
- Stainless Steel 302 (A2)



302 SS

EXTERNAL



Part No.	Description	mm	mm	Thread /mm	qty	qty - packs	
TP582	Trade Pack	14-10 x 75	5mm Int hex	35	50	20	20
TP584	Trade Pack	14-10 x 100	5mm Int hex	35	65	20	20



■ 14 Gauge - Coarse Thread
- Stainless Steel 302 (A2)



Part No.	Description	mm	mm	Thread /mm	qty	qty - packs	
TT582	Trade Tub	14-10 x 75 - 302SS	5mm Int hex	35	50	250	n/a
TT584	Trade Tub	14-10 x 100 - 302SS	5mm Int hex	35	65	250	n/a



■ 14 Gauge - Coarse Thread
- Stainless Steel 316 (A4)



Part No.	Description	mm	mm	Thread /mm	qty	qty - packs	
TT581	Trade Tub	14-10 x 75 - 316SS	5mm Int hex	35	50	100	n/a
TT583	Trade Tub	14-10 x 100 - 316SS	5mm Int hex	35	65	100	n/a



Type 17 Bugle Batten

■ 14 Gauge - Coarse Thread - Zinc Yellow



ZINC EXTERNAL



Part No.	Description	mm	mm	Thread /mm	qty	qty - packs
TP586	Trade Pack	14-10 x 75	5mm Int hex	35	50	20
TP588	Trade Pack	14-10 x 100	5mm Int hex	35	65	20



Part No.	Description	mm	mm	Thread /mm	qty	qty - packs
TT585	Trade Tub	14-10 x 50	5mm Int hex	35	30	100
TT586	Trade Tub	14-10 x 75	5mm Int hex	35	50	100
TT588	Trade Tub	14-10 x 100	5mm Int hex	35	65	100



Type 17 Bugle Batten

■ 14 Gauge - Coarse Thread - Category 3

NAUTILUS® 3



IC3 EXTERNAL



Part No.	Description	mm	mm	Thread /mm	qty	qty - packs
TP572	Trade Pack	14-10 x 50	5mm Int hex	30	30	20
TP574	Trade Pack	14-10 x 75	5mm Int hex	35	50	20
TP576	Trade Pack	14-10 x 100	5mm Int hex	35	65	20



Part No.	Description	mm	mm	Thread /mm	qty	qty - packs
TT572	Trade Tub	14-10 x 50	5mm Int hex	30	30	100
TT574	Trade Tub	14-10 x 75	5mm Int hex	35	50	100
TT576	Trade Tub	14-10 x 100	5mm Int hex	35	65	100
TT578	Trade Tub	14-10 x 125	5mm Int hex	35	85	100
TT580	Trade Tub	14-10 x 150	5mm Int hex	35	100	100



Knife Thread CSK Decking Screw

■ 10 Gauge - Coarse Thread 304 (A2) Stainless Steel.



304 SS EXTERNAL

DRIVER BIT INCLUDED



IC Find #	Part No.	Description	mm	mm	Thread /mm	qty	qty - packs
TP634	Trade Pack	10-12 x 50	CSK / No.2 Sqr	25	34	50	20
TP636	Trade Pack	10-12 x 65	CSK / No.2 Sqr	25	44	50	20



Trim Head Decking Screw

■ 9 Gauge - Coarse Thread 304 (A2) Stainless Steel



304 SS EXTERNAL

DRIVER BIT INCLUDED



Part No.	Description	mm	mm	Thread /mm	qty	qty - packs
TP626	Trade Pack	9-9 x 53	CSK / No.2 Sqr	25	38	100 20



Trim Head Decking Screw

■ 9 Gauge - Coarse - Top Coat - Square Drive - Category 4



IC4 EXTERNAL

DRIVER BIT INCLUDED



Part No.	Description	mm	mm	Thread /mm	qty	qty - packs
TP630	Trade Pack	9-9 x 53	CSK / No.2 Sqr	25	38	100 20



Type 17 CSK Head

■ 6 Gauge - Coarse Thread - Zinc Yellow

■ 10 Gauge - Coarse Thread - Category 3



ZINC INTERNAL

IC3 EXTERNAL



Part No.	Description	mm	mm	Thread /mm	qty	qty - packs		
TP592	Trade Pack	6-18 x 25	CSK / PH2	16	Full	100 20		
TP598	Trade Pack	8-15 x 25	CSK / PH2	18	Full	100 20		
TP602	Trade Pack	10-12 x 30	CSK / PH2	25	Full	50 20		
TP604	Trade Pack	TP612	Trade Pack	10-12 x 40	CSK / PH2	25	Full	50 20
TP606	Trade Pack	TP614	Trade Pack	10-12 x 50	CSK / PH2	25	36	50 20
TP608	Trade Pack			10-12 x 75	CSK / PH2	25	50	50 20



Part No.	Description	mm	mm	Thread /mm	qty	qty - packs
TT602	Trade Tub	10-12 x 30	CSK / PH2	25	Full	250 n/a
TT604	Trade Tub	10-12 x 40	CSK / PH2	25	Full	250 n/a



Needle Point Bugle Head FINE Thread



■ 6, 7, 8 Gauge - Zinc Yellow - Fine Thread for Fixing Plasterboard

ZINC

INTERNAL



Part No.	Description	mm	mm	Thread /mm	qty	qty - packs
TP702	Trade Pack 6-18 x 25	PH2	0.5 - 0.75	Full	100	20
TP704	Trade Pack 6-18 x 32	PH2	0.5 - 0.75	Full	100	20
TP708	Trade Pack 6-18 x 41	PH2	0.5 - 0.75	Full	100	20
TP710	Trade Pack 6-18 x 45	PH2	0.5 - 0.75	Full	100	20
TP720	Trade Pack 7-15 x 50	PH2	0.5 - 0.75	Full	100	20
TP722	Trade Pack 7-15 x 57	PH2	0.5 - 0.75	50	100	20
TP726	Trade Pack 8-15 x 65	PH2	0.5 - 0.75	50	50	20
TP728	Trade Pack 8-15 x 75	PH2	0.5 - 0.75	50	50	20



Needle Point CSK Head Villaboard® 4 Nibb



■ 8 Gauge - Self Embedding Head

ZINC

INTERNAL



Part No.	Description	mm	mm	Thread /mm	qty	qty - packs
TP796	Trade Pack 8-15 x 20	PH2	0.5 - 0.75	Full	100	20
TP798	Trade Pack 8-15 x 30	PH2	0.5 - 0.75	Full	100	20



Needle Point Flathead



■ 10 Gauge - Zinc Yellow

■ 10 Gauge - Category 3

NAUTILUS® 3

ZINC

INTERNAL

IC3

EXTERNAL



Part No.	Description	mm	mm	Thread /mm	qty	qty - packs
TP754	Trade Pack 10-15 x 16	Wafer / PH2	0.55 - 1.20	Full	100	20



Needle Point Button Head

8 Gauge - Zinc Yellow



ZINC INTERNAL



Part No.	Description	Head	mm	Thread /mm	qty	qty - packs
TP800	Trade Pack	PH2	0.5 - 0.75	Full	100	20
TP802	Trade Pack	PH2	0.5 - 0.75	Full	100	20
TP804	Trade Pack	PH2	0.5 - 0.75	Full	100	20
TP806	Trade Pack	PH2	0.5 - 0.75	Full	100	20
TP808	Trade Pack	PH2	0.5 - 0.75	Full	100	20



Needle Point Hex Head

8, 10 Gauge - Category 4

10 Gauge - EPDM Sealing Washer - Category 4



NAUTILUS 4

IC4 EXTERNAL

IC4 EXTERNAL With Sealing Washer



IC Find #	Part No.	IC Find #	Part No.	Description	Head	mm	thread /mm	qty	qty - packs
TP820	Trade Pack			8-15 x 12	Hex 1/4	0.5 - 0.75	Full	100	20
TP824	Trade Pack	TP824W	Trade Pack	10-12 x 20	Hex 5/16	0.5 - 0.75	Full	100	20



Needle Point Pan Head

7 Gauge - Zinc Yellow



ZINC INTERNAL



IC Find #	Part No.	Description	Head	mm	Thread /mm	qty	qty - packs
TP832	Trade Pack	7-16 x 20	PH2	0.5 - 0.75	Full	100	20

Distributors!

Ask your ICCONS® representative how to get your TRADE PACK stand





Chipboard - 6 Nibb

■ 8 & 10 Gauge - Zinc Yellow

■ 8 & 10 Gauge - Category 3



ZINC

INTERNAL

IC3

EXTERNAL



Part No.	Trade Pack	Part No.	Trade Pack	Description	mm	mm	thread / mm	qty	qty - packs
TP020	Trade Pack	TP060	Trade Pack	8-9 x 20	CSK / PH2	18	Full	100	20
TP022	Trade Pack	TP062	Trade Pack	8-9 x 25	CSK / PH2	18	Full	100	20
TP024	Trade Pack	TP064	Trade Pack	8-9 x 28	CSK / PH2	18	19	100	20
TP026	Trade Pack	TP066	Trade Pack	8-9 x 32	CSK / PH2	18	21	100	20
TP028	Trade Pack	TP068	Trade Pack	8-9 x 35	CSK / PH2	18	23	100	20
TP030	Trade Pack	TP070	Trade Pack	8-9 x 40	CSK / PH2	18	27	100	20
TP032	Trade Pack	TP072	Trade Pack	8-9 x 45	CSK / PH2	18	30	100	20
TP040	Trade Pack	TP074	Trade Pack	8-9 x 50	CSK / PH2	18	33	100	20
TP042	Trade Pack	TP076	Trade Pack	8-9 x 57	CSK / PH2	18	38	100	20
TP050	Trade Pack	TP080	Trade Pack	10-8 x 65	CSK / PH2	25	43	50	20
TP052	Trade Pack	TP082	Trade Pack	10-8 x 75	CSK / PH2	25	50	50	20
TP054	Trade Pack	TP084	Trade Pack	10-8 x 100	CSK / PH2	25	67	50	20

Download the ICCONS® App today!

Features:

- Adhesive Volume Calculator
- What's New
- View Our Catalogue
- Find A Distributor
- NCC F.A.Q. Sheet & NCC Products
- Contact us



Available on the App Store



GET IT ON Google Play



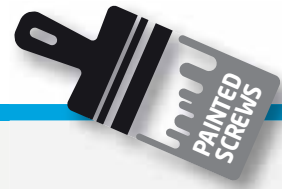

HOW TO ORDER ICCONS® PAINTED SCREWS

1. Select the Product Number prefix from the following ICCONS® painted screw range eg 104-??.
Additional screw sizes not listed can be painted and are available upon request.

Part No	Descriptive
104-??	10-16x

Painted stock available on request

2. Then select the colour code from the colour table below and add it to the part number prefix eg. for Jasper 104-JA (this will be the part number to order from). Other colours available upon request.

Part No	Descriptive
104-JA	10-16x

Painted stock available on request

3. Contact ICCONS® for availability and lead times.

BA BASALT®	CC CLASSIC CREAM™	CG COTTAGE GREEN®	CO COVE™	DO DEEP OCEAN®
DU DUNE®	EH EVENING HAZE®	GU GULLY™	IS IRONSTONE®	JA JASPER®
LO LOFT®	MA MANGROVE®	MO MONUMENT®	MR MANOR RED®	NS NIGHT SKY®
PA PAPERBARK®	PE PALE EUCALYPT®	SA SANDBANK®	SG SHALE GREY™	SM SURF MIST®
TE TERRAIN®	WA WALLABY®	WG WOODLAND GREY®	WI WILDERNESS®	WS WINDSPRAY®

*Other screws & colours available upon request.



PAINTED SCREWS



Self Drilling Hex Head - Coarse

■ 10 Gauge - Category 4

■ 10, Gauge - EPDM Sealing Washer - Category 4

NAUTILUS® 4

IC4 EXTERNAL
IC4 EXTERNAL With Sealing Washer



Part No	Part No	Description	mm	mm	thread /mm	qty	qty	
104-??	104W-??	Painted Screw	10-16x 16	Hex 5/16	0.75-3.50	Full	1000	4000
106-??	106W-??	Painted Screw	10-16 x 25	Hex 5/16	0.75-3.50	Full	1000	3000

Painted Stock available in additional sizes available on request, please contact ICCONS® for availability & lead times



Self Drilling Hex Head - Coarse

■ 12 Gauge - Category 4

■ 12 Gauge - EPDM Sealing Washer - Category 4

NAUTILUS® 4

IC4 EXTERNAL
IC4 EXTERNAL With sealing Washer



Part No	Part No	Description	mm	mm	thread /mm	qty	qty	
110-??	110W-??	Painted Screw	12-14 x 20	Hex 5/16	1.00-4.50	Full	500	2000
112-??	112W-??	Painted Screw	12-14 x 35	Hex 5/16	1.00-4.50	Full	1000	1000
	114W-??	Painted Screw	12-14 x 45	Hex 5/16	1.00-4.50	Full	1000	1000

Painted Stock available in additional sizes available on request, please contact ICCONS® for availability & lead times



RoofStars® Hex Head

■ 13 Gauge - Metal Roof Sheet to Steel or Timber Battens

NAUTILUS® 4

IC4 EXTERNAL With Sealing Washer



Part No	Description	mm	mm	thread /mm	qty	qty
162W-??	Painted Screw 13-11 X 50	Hex 5/16	0.55 - 1.90	33	1000	1000

Painted Stock available in additional sizes available on request, please contact ICCONS® for availability & lead times



Self Drilling Hex Head - Top Grip

■ 12 Gauge - with EPDM Sealing Washer - Coarse - Category 4
Self Drilling Hex - top grip roofing screw.

NAUTILUS® 4

IC4 EXTERNAL With Sealing Washer



Part No	Description	mm	mm	thread /mm	qty	qty
156W-??	Painted Screw 12-14 x 42	Hex 5/16	1.00 - 4.50	Full	1000	1000
158W-??	Painted Screw 12-14 x 42	Hex 5/16	1.00 - 4.50	Full	1000	1000

Painted Stock available in additional sizes available on request, please contact ICCONS® for availability & lead times

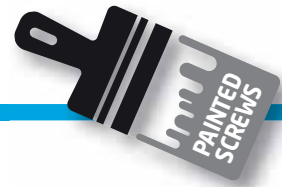

CYCLONIX®

Self Drilling Hex Head

■ 14 Gauge - Category 4



IC4 EXTERNAL



Part No.	Description	Description	mm	mm	Thread /mm	qty
370X-??	Painted Screw	14-10 x 55	Hex 3/8	1.00 - 5.00	42	500
374X-??	Painted Screw	14-10 x 65	Hex 3/8	1.00 - 5.00	42	500

*Part No. SDHXTG14065C4X is suitable for cyclonic applications subject to letter of opinion from FYFE Consulting Engineers (Ref. 51176-1). This part is not referenced in the NT Deemed to comply manual (DTCM).



CYCLONIX®

Type 17 Hex Head

■ 14 Gauge - Category 4



IC4 EXTERNAL



Part No.	Description	Description	mm	mm	Thread /mm	Tub qty
670X-??	Painted Screw	14-10 x 50	Hex 3/8	35	37	500
674X-??	Painted Screw	14-10 x 65	Hex 3/8	35	52	500
524X-??*	Painted Screw	14-10 x 75	Hex 3/8	35	52	500

*Part No. T17HXTG14075C4X is suitable for cyclonic applications subject to letter of opinion from FYFE Consulting Engineers (Ref. 51176-5). This part is not referenced in the NT Deemed to comply manual (DTCM).



Type 17 Hex Head

Metal Roof Sheet to Thin Steel or Timber Battens

■ 10 Gauge - Category 4

■ 10 & 12 Gauge - EPDM Sealing Washer - Category 4



IC4 EXTERNAL IC4 EXTERNAL With Sealing Washer



Part No	Part No	Description	mm	mm	thread /mm	qty	qty	
500-??	500W-??	Painted Screw	10-12 x 25	Hex 5/16	23	Full	1000	3000
	504W-??	Painted Screw	12-11 x 25	Hex 5/16	23	Full	500	2000

Painted Stock available in additional sizes available on request, please contact ICCONS® for availability & lead times.



Type 17 Hex Head

Metal Roof Sheet to Thin Steel or Timber Battens

■ 12 Gauge - with EPDM Sealing Washer - Coarse Thread - Category 4



IC4 EXTERNAL With Sealing Washer



Part No	Description	Description	mm	mm	thread /mm	qty	qty
546W-??	Painted Screw	12-11 x 50	Hex 5/16	30	Full	1000	1000
548W-??	Painted Screw	12-11 x 65	Hex 5/16	30	Full	1000	1000

Painted Stock available in additional sizes available on request, please contact ICCONS® for availability & lead times.



Innovative Drilling & Cutting

DUSTLESS VACUM SDS BITS
PROTECTING YOUR HEALTH
THROUGH IMPROVED AIR QUALITY

TRIJET SDS PLUS
LONG LIFE SUPER FAST
AND CUTS THROUGH REBAR

FASTEST TILE DRILL BIT
CERAMIC / PORCELAIN DRILL - NO WATER
USED WITH ANGLE GRINDER



Heller drill bits carry the independent PGM certificate assuring safe connection systems

European Technical Approvals / Assessments (ETA's) for anchors and their installation demands the use of suitable drill bits.

Suitable drill bits can be identified under site conditions by simply looking for the PGM mark on the drill bit. The PGM mark is a symbol of quality and provides the installer with a correctly drilled hole for safe anchor installation.



ISO 9001 quality management
Heller drill bits are made under certificate ensuring highest quality



Heller hammer drill bits are developed for use in all power tool brands



Heller is the first pure drill bit manufacturer to be awarded the independently tested hand-arm-vibration certificate according to the EU vibration guideline 2002/44/EC



Heller hammer drill bits are engineered and Made in Germany

ENDURO

SDS MAX
Trijet & YCutter



Page 179

SDS Plus

Professional Plus
(3 cutter)



Page 180

XFORCE

SDS Plus
Professional Plus
(4 cutter)



Page 182

BionicPro

SDS Plus
Professional Plus
(2 cutter)



Page 184

Prefix

SDS Plus
Economy
(2 cutter)



Page 186

Cera Expert

Tile cutting Solutions



Page 187

ENDURO

points & Chisels
SDS MAX & SDS +



Page 188

Drill Sets

HS Drill bits & Driver Bits



Page 190



Dustless Drilling
Page 177



heller
get a bit more



DRILLING





Crystal Line Silica Dubbed as the 'new asbestos' by industry experts.

Silicosis, the most common occupational lung disease in the world.

Crystalline Silica, also known as Silica Dust affects the deep airway of the human Pulmonary System. Over extended periods of exposure to Silica, particles become lodged on the lung tissue causing scarring, ultimately resulting in long-term and sometimes life threatening breathing complications. It is estimated that on average, 600,000 Australians are exposed to Silica Dust each year, leaving approximately 1% of those exposed (6,000 people) with this deadly lung disease. The tragedy is that **Crystalline Silica is a known 'workplace risk'**.

DONE & DUSTLESS™



WORK SAFER: With growing concern of concrete & stone dust causing diseases such as Silicosis. The ICCONS SET-SAFE DE drastically reduces the exposure by eliminating dust created from drilling holes.



WORK FASTER: Drilling and hole cleaning in 1 step. This saves time and money, with the added benefit of reducing the clean-up of dust on the job site.



WORK SMARTER: A drill bit that cleans as you go, reduces your health risk, increases anchor reliability and saves installation time.



SET-SAFE DE



Dust free drilling!
revolutionary drilling
and cleaning in 1 step



SET-SAFE DE display
also available



WORK SAFER: With growing concern of concrete & stone dust causing diseases such as Silicosis. The ICCONS SET-SAFE DE drastically reduces the exposure by eliminating dust created from drilling holes.



WORK FASTER: Drilling and hole cleaning in 1 step. This saves time and money, with the added benefit of reducing the clean-up of dust on the jobsite.



WORK SMARTER: A drill bit that cleans as you go, reduces your health risk, increases anchor reliability and saves installation time.

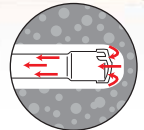
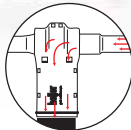

DUSTER PRO



Turn Your Drill I
Bits into Dustless
drill I bits





heller SDS Max SET-SAFE DE 14 - 35mm sizes

For use with "M" Class vacuums
≥40 litres/sec airflow,
≥200 mbar suction
& max hose length 5 metres



Part No.	Description	mm	mm	mm	qty
HMAXDE14-600	SDS Max DE 14 X 600mm (28620 6)	14	600	400	1
HMAXDE16-600	SDS Max DE 16 X 600mm (28621 3)	16	600	400	1
HMAXDE18-600	SDS Max DE 18 X 600mm (28622 0)	18	600	400	1
HMAXDE20-600	SDS Max DE 20 X 600mm (28623 7)	20	600	400	1
HMAXDE22-600	SDS Max DE 22 X 600mm (28624 4)	22	600	400	1
HMAXDE24-600*	SDS Max DE 24 X 600mm (28825 5)	24	600	400	1
HMAXDE25-600	SDS Max DE 25 X 600mm (28625 1)	25	600	400	1
HMAXDE28-600	SDS Max DE 28 X 600mm (28626 8)	28	600	400	1
HMAXDE30-600*	SDS Max DE 30 X 600mm (28627 8)	30	600	400	1
HMAXDE32-600*	SDS Max DE 32 X 600mm (28628 8)	32	600	400	1
HMAXDE35-600*	SDS Max DE 35 X 600mm (28629 8)	35	600	400	1

* available on request, lead times may apply

Drill recommendation: Drill Ø ≤ 25mm - SDS Max upto 5kg with 10 Joule (max)
Drill Ø ≥ 25mm - SDS Max upto 8kg with 13 Joule (max)

heller SDS Plus SET-SAFE DE 6 - 24mm sizes

For use with "M" Class vacuums
≥40 litres/sec airflow,
≥200 mbar suction
& max hose length 5 metres



Part No.	Description	mm	mm	mm	qty
HBDE06-220	SDS PLUS DE 6 x 220 - 2- Cutter (29630 4) NEW	6	220	100	1
HBDE08-270	SDS PLUS DE 8 x 270 - 2- Cutter (28970 2)	8	270	150	1
HBDE10-270	SDS PLUS DE 10 x 270 - 2- Cutter (28971 9)	10	270	150	1
HBDE12-320	SDS PLUS DE 12 x 320 - 2- Cutter (28783 8)	12	320	200	1
HBDE14-370	SDS PLUS DE 14 x 370 - 2- Cutter (28784 5)	14	370	250	1
HBDE16-370	SDS PLUS DE 16 x 370 - 2- Cutter (28786 9)	16	370	250	1
HBDE18-370	SDS PLUS DE 18 x 370 - 2- Cutter (28787 6)	18	370	250	1
HBDE20-370	SDS PLUS DE 20 x 370 - 2- Cutter (28788 3)	20	370	250	1
HBDE24-370	SDS PLUS DE 24 x 370 - 2- Cutter (28789 0)	24	370	250	1

Drill recommendation: Drill Ø ≤ 25mm - SDS Plus upto 4kg with 4.2 Joule (max)

heller Duster PRO Turn Your Drill Bits into Dustless drill bits



The Simple Solution For Dust

- Extraction adapter suitable for building site vacuum cleaners.
- Dust is extracted from the material surface.
- Automatically adheres to the wall with vacuum suction.
- Suitable for drill bit diameters of up to 42mm.



Part No.	Description	qty
HDPRO-CD	Heller Duster Pro 45PCE Counter Display	1



ENDURO

1. Maximum service life
2. Powerful in reinforced concrete
3. Impressive drilling speed



Trijet

Three-winged bit with sinks for improved power transmission



Y-Cutter

Especially powerful and robust – even in case of reinforcement hits – thanks to stabilised main cutting edge



Highest service life in concrete and reinforcements on account of the enlarged rounded secondary cutting edge

Highest service life due to extremely wear-resistant "one-phase hard metal alloy"

New carbide design guarantees best possible stability and wear resistance

Stable head geometry by inserted hard metal alloy - withstands reinforcement hits even

More hold in tapping and prevention of flaking on account of reinforced two point centring tip

Extremely quick drill dust transport without deflagration due to the wide spiral shape

Effective transfer of hammer energy thanks to optimised carbide point angle

Vibration-optimised triple spiral

Extremely quick drilling progress on account of large-volume Twinmax 3D-helix

DuraTec hardening procedure using high-temperature soldering and shot peening technology

Certified by the Masonry Drill Bit Testing Association (PGM) according to the requirements of the German Institute for Building Technology (DIBt)





heller EnDuro SDS Max Trijet 12 - 16mm sizes



Part No.	Description	mm	mm	mm	qty
HMAX12-340	12 x 340mm (28178 2)	12	340	200	1
HMAX12-540	12 x 540mm (28179 9)	12	540	400	1
HMAX14-340	14 x 340mm (28183 6)	14	340	200	1
HMAX14-540	14 x 540mm (28184 3)	14	540	400	1
HMAX16-340	16 x 340mm (28188 1)	16	340	200	1
HMAX16-540	16 x 540mm (28189 8)	16	540	400	1
HMAX16-940	16 x 940mm (28191 1)	16	940	800	1

heller EnDuro SDS Max Y Cutter 18 - 30mm sizes



Part No.	Description	mm	mm	mm	qty
HMAX18-340	18 x 340mm (22363 8)	18	340	200	1
HMAX18-540	18 x 540mm (22364 5)	18	540	400	1
HMAX20-320	20 x 320mm (22365 2)	20	320	200	1
HMAX20-520	20 x 520mm (22366 9)	20	520	400	1
HMAX20-720	20 x 720mm (28194 2)	20	720	600	1
HMAX22-320	22 x 320mm (22368 3)	22	320	200	1
HMAX22-520	22 x 520mm (22369 0)	22	520	400	1
HMAX24-320	24 x 320mm (22371 3)	24	320	200	1
HMAX24-520	24 x 520mm (22372 0)	24	520	400	1
HMAX25-520	25 x 520mm (22374 4)	25	520	400	1
HMAX25-920	25 x 920mm (22375 1)	25	920	800	1
HMAX26-340	26 x 340mm (23113 8)	26	340	200	1
HMAX26-520	26 x 520mm (23114 5)	26	520	400	1
HMAX28-340	28 x 340mm (22377 5)	28	340	200	1
HMAX28-520	28 x 520mm (22378 2)	28	520	400	1
HMAX30-520	30 x 520mm (22381 2)	30	520	400	1
HMAX35-520	35 x 520mm (22387 4)	35	520	400	1
HMAX38-520	38 x 520mm (22390 4)	38	520	400	1
HMAX40-520	40 x 520mm (22392 8)	40	520	400	1

heller Duster PRO Turn Your Drill Bits into Dustless drill bits



The Simple Solution For Dust

- Extraction adapter suitable for building site vacuum cleaners.
- Dust is extracted from the material surface.
- Automatically adheres to the wall with vacuum suction.
- Suitable for drill bit diameters of up to 42mm.



Part No.	Description	qty
HDPRO-CD	Heller Duster Pro 45PCE Counter Display	1



DRILLING



Trijet

Premium Long Life, Hammer Drill Bits

SUPERIOR PERFORMANCE - TOTALLY IN COMMAND

- New generation of hammer bits: powerful, fast & consistent
- Impeller cutting edge with 3 blades for more effective material removal
- Increased power transmission when drilling thanks to shaft-form head design
- Robust head geometry thanks to embedded tungsten carbide head - will withstand multi impacts with reinforcement
- Compared to an average 2-cutter the Trijet achieves nine times the service life when drilling through rebar. Please note: Drilling through reinforced concrete is only permitted after approval by the structural engineer.
- Extremely fast removal of dust without blow-out thanks to wide spiral form
- Optimised low-vibration triple spiral
- DuraTec hardening technique by means of high-temperature soldering and shot-blasting technology
- Certified by the Prüfgemeinschaft Mauerbohrer (PGM) in accordance with the requirements of the Deutsches Institut für Bautechnik (DIBt)



heller Trijet SDS Plus Premium Long Life, Hammer Drill Bits



Part No.	Description				qty
		mm	mm	mm	
HTJ05.0-110	5.0 x 110mm (26740 3)*	5.0	110	50	1
HTJ05.0-160	5.0 x 160mm (26741 0)*		160	100	1
HTJ05.5-110	5.5 x 110mm (26742 7)*	5.5	110	50	1
HTJ05.5-160	5.5 x 160mm (26743 4)*		160	100	1
HTJ06.0-110	6.0 x 110mm (26744 1)*	6.0	110	50	1
HTJ06.0-160	6.0 x 160mm (26745 8)*		160	100	1
HTJ06.0-210	6.0 x 210mm (26746 5)*		210	150	1
HTJ06.5-110	6.5 x 110mm (26748 9)*	6.5	110	50	1
HTJ06.5-160	6.5 x 160mm (26749 6)*		160	100	1
HTJ06.5-210	6.5 x 210mm (26750 2)*		210	150	1
HTJ07.0-160	7.0 x 160mm (26751 9)	7.0	160	100	1
HTJ08.0-160	8.0 x 160mm (26754 0)*	8.0	160	100	1
HTJ08.0-210	8.0 x 210mm (26755 7)		210	150	1
HTJ08.0-260	8.0 x 260mm (26756 4)		260	200	1
HTJ08.0-310	8.0 x 310mm (26757 1)		310	250	1
HTJ10.0-160	10.0 x 160mm (26760 1)*	10.0	160	100	1
HTJ10.0-210	10.0 x 210mm (26761 8)*		210	150	1
HTJ10.0-260	10.0 x 260mm (26762 5)	10.0	260	200	1
HTJ10.0-310	10.0 x 310mm (26763 2)		310	250	1

SDS PLUS Trijet



heller Trijet SDS Plus Premium Long Life, Hammer Drill Bits Cont...



Part No.	Description	mm	mm	mm	qty
HTJ12.0-160	12.0 x 160mm (26766 3)*	12.0	160	100	1
HTJ12.0-210	12.0 x 210mm (26767 0)*		210	150	1
HTJ12.0-260	12.0 x 260mm (26768 7)*		260	200	1
HTJ12.0-310	12.0 x 310mm (26769 4)		310	250	1
HTJ13.0-160	13.0 x 160mm (28086 0)	13.0	160	100	1
HTJ13.0-250	13.0 x 250mm (28087 7)		250	200	1
HTJ13.0-300	13.0 x 300mm (28088 4)		300	250	1
HTJ14.0-250	14.0 x 250mm (26774 8)*	14.0	250	200	1
HTJ15.0-160	15.0 x 160mm (28089 1)		160	100	1
HTJ15.0-250	15.0 x 250mm (28090 7)		250	200	1
HTJ15.0-300	15.0 x 300mm (28091 4)		300	250	1
HTJ16.0-200	16.0 x 200mm (26778 6)	16.0	200	150	1
HTJ16.0-250	16.0 x 250mm (26779 3)*		250	200	1
HTJ16.0-300	16.0 x 300mm (26780 9)		300	250	1
HTJ-MODULE 90	Trijet Display Module 90 PCE (2750002) (5 of each pieces of the Trijet range marked with "*" are included in the stand)				1

heller Y-Cutter Ergo SDS Plus Premium Drill Bits



Part No.	Description	mm	mm	mm	qty
HBY16.0-250	16.0 x 250mm (22522 9)	16.0	250	200	1
HBY16.0-450	16.0 x 450mm (22523 6)		450	400	1
HBY18.0-300	18.0 x 300mm (22524 3)	18.0	300	250	1
HBY18.0-450	18.0 x 450mm (22525 0)		450	400	1
HBY20.0-300	20.0 x 300mm (22526 7)	20.0	300	250	1
HBY20.0-450	20.0 x 450mm (22527 4)		450	400	1
HBY22.0-450	22.0 x 450mm (22528 1)	22.0	450	400	1
HBY24.0-250	24.0 x 250mm (22529 8)	24.0	250	200	1
HBY24.0-450	24.0 x 450mm (22530 4)		450	400	1
HBY25.0-450	25.0 x 450mm (22531 1)	25.0	450	400	1

heller Duster PRO Turn Your Drill Bits into Dustless drill bits



The Simple Solution For Dust

- Extraction adapter suitable for building site vacuum cleaners.
- Dust is extracted from the material surface.
- Automatically adheres to the wall with vacuum suction.
- Suitable for drill bit diameters of up to 42mm.



Part No.	Description	qty
HDPRO-CD	Heller Duster Pro 45PCE Counter Display	1

SDS PLUS Trijet



XFORCE Combines robustness with speed

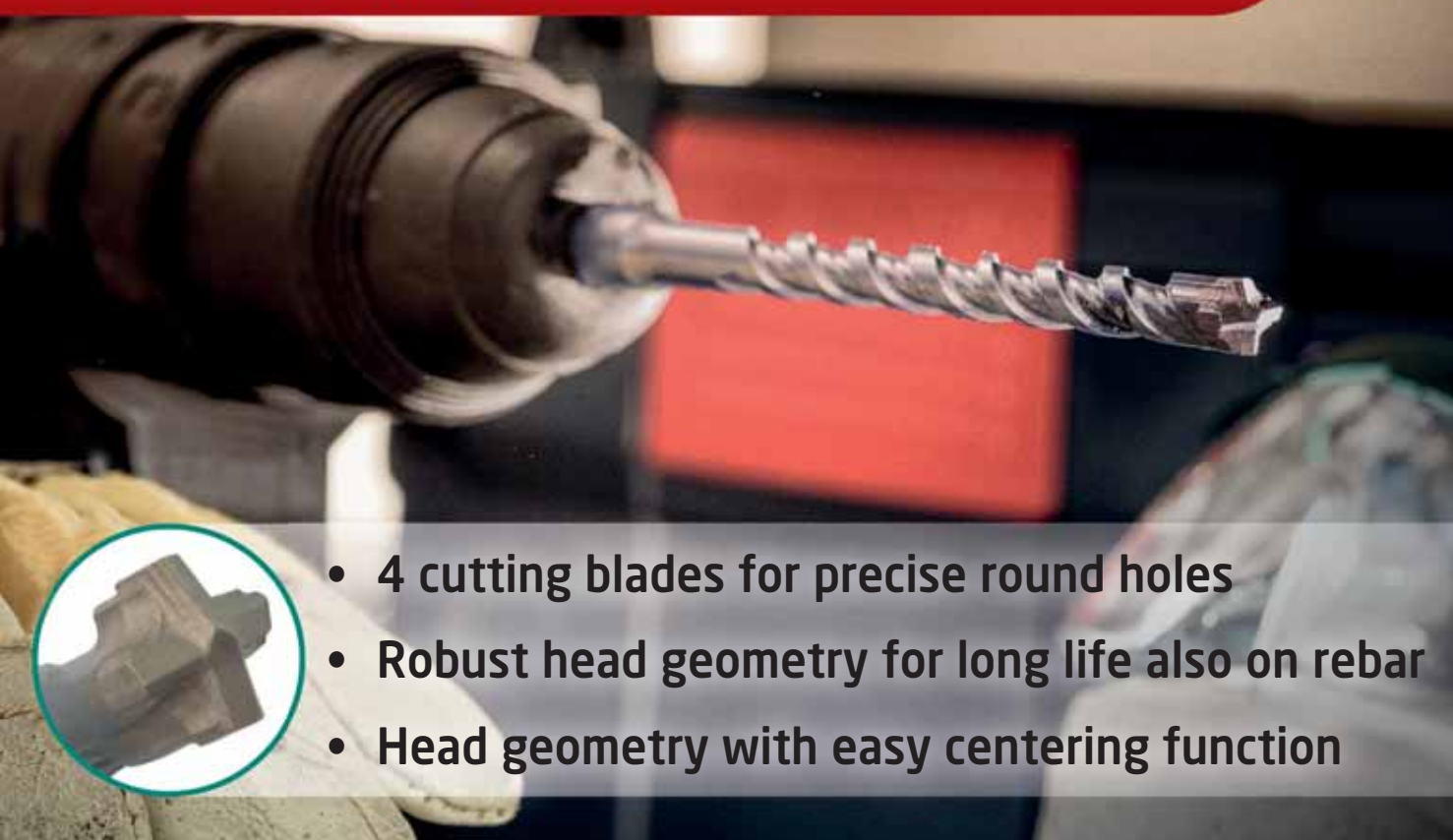

- 4 cutting blades for precise round holes
- Robust head geometry for long life also on rebar
- Head geometry with easy centering function

Reduced vibration, Comfortable drilling

Large TwinMax 3D flute with 4 edge design for superb transport of dust and minimized dust explosion, even in deep holes

Optimised head and flute design for extra efficient transport of dust



HST hardened to avoid breakage

Robust head geometry for long life also on rebar

Professional 4 cutter Drill Bit





heller XForce SDS Plus Premium Long Life, 4 Cutter Drill Bits



Part No.	Description	mm	mm	mm	qty
HXF05.0-110	5.0 x 110mm (28996 2)	5.0	110	50	1
HXF05.0-160	5.0 x 160mm (28997 9)		160	100	1
HXF05.5-110	5.5 x 110mm (29108 8)	5.5	110	50	1
HXF05.5-160	5.5 x 160mm (29109 5)		160	100	1
HXF06.0-110	6.0 x 110mm (28998 6)	6.0	110	50	1
HXF06.0-160	6.0 x 160mm (28999 3)		160	100	1
HXF06.0-210	6.0 x 210mm (29000 5)		210	150	1
HXF06.5-110	6.5 x 110mm (29110 1)	6.5	110	50	1
HXF06.5-160	6.5 x 160mm (29111 8)		160	100	1
HXF06.5-210	6.5 x 210mm (29112 5)		210	150	1
HXF07.0-160	7.0 x 160mm (29114 9)	7.0	160	100	1
HXF08.0-110	8.0 x 110mm (29002 9)	8.0	110	50	1
HXF08.0-160	8.0 x 160mm (29003 6)		160	100	1
HXF08.0-210	8.0 x 210mm (29004 3)		210	150	1
HXF08.0-260	8.0 x 260mm (29005 0)		260	200	1
HXF10.0-110	10.0 x 110mm (29008 1)	10.0	110	50	1
HXF10.0-160	10.0 x 160mm (29009 8)		160	100	1
HXF10.0-210	10.0 x 210mm (29010 4)		210	150	1
HXF10.0-260	10.0 x 260mm (29011 1)		260	200	1
HXF12.0-160	12.0 x 160mm (29014 2)	12.0	160	100	1
HXF12.0-210	12.0 x 210mm (29015 9)		210	150	1
HXF12.0-260	12.0 x 260mm (29016 6)		260	200	1
HXF12.0-310	12.0 x 310mm (29017 3)		310	250	1
HXF12.0-450	12.0 x 450mm (29018 0)		450	400	1
HXF14.0-260	14.0 x 260mm (29022 7)	14.0	260	200	1
HXF16.0-210	16.0 x 210mm (29026 5)	16.0	210	150	1
HXF16.0-260	16.0 x 260mm (29027 2)		260	200	1
HXF16.0-300	16.0 x 300mm (29028 9)		300	250	1

heller Duster PRO Turn Your Drill Bits into Dustless drill bits



The Simple Solution For Dust

- Extraction adapter suitable for building site vacuum cleaners.
- Dust is extracted from the material surface.
- Automatically adheres to the wall with vacuum suction.
- Suitable for drill bit diameters of up to 42mm.



Part No.	Description	qty
HDPRO-CD	Heller Duster Pro 45PCE Counter Display	1

SDS PLUS X Force



DRILLING

Bionic Pro

IMPROVED LIFETIME IN CONCRETE AND REINFORCEMENT

- Rounded cutting edges and improved carbide plate geometry
- Stabilised head geometry for impressive robustness upon reinforcement impacts
- Patented double cutting edge design as per the bionic concept

COMFORTABLE AND SIMPLE DRILLING WITHOUT THE EFFECTS OF DUST EXPLOSION

- Computer calculated Twinmax-3D spiral with changing flute widths (narrow/ wide)
- The innovative spiral design provides optimal removal of drill dust

IMPROVED DURABILITY

- Strengthened carbide geometry with double centering point
- Two-point centering area for an optimal power distribution

HIGHEST DRILLING SPEED

- Twinmax-3D spiral flute with a large volume transport helix
- Optimised head geometry with large tip angle



heller Bionic Pro SDS Plus Professional Drill Bits



Part No.	Description	mm	mm	mm	qty
HB04.0-160	4.0 x 160mm (22016 3)	4.0	160	100	1
HB05.0-110	5.0 x 110mm (15620 2)	5.0	110	50	1
HB05.0-160	5.0 x 160mm (17650 7)		160	100	1
HB05.0-210	5.0 x 210mm (23642 3)		210	150	1
HB05.5-110	5.5 x 110mm (15965 4)	5.5	110	50	1
HB05.5-160	5.5 x 160mm (17298 1)		160	100	1
HB05.5-210	5.5 x 210mm (24158 8)		210	150	1
HB06.0-110	6.0 x 110mm (15622 6)	6.0	110	50	1
HB06.0-160	6.0 x 160mm (15623 3)		160	100	1
HB06.0-210	6.0 x 210mm (16813 7)		210	150	1
HB06.0-360	6.0 x 360mm (22263 1)		360	300	1
HB06.5-110	6.5 x 110mm (18308 6)	6.5	110	50	1
HB06.5-160	6.5 x 160mm (19350 4)		160	100	1
HB06.5-210	6.5 x 210mm (16304 0)		210	150	1
HB06.5-360	6.5 x 360mm (28085 3)		360	300	1
HB07.0-110	7.0 x 110mm (19874 5)	7.0	110	50	1
HB07.0-160	7.0 x 160mm (15625 7)		160	100	1
HB08.0-110	8.0 x 110mm (15966 1)	8.0	110	50	1
HB08.0-160	8.0 x 160mm (15626 4)		160	100	1
HB08.0-210	8.0 x 210mm (15627 1)		210	150	1
HB08.0-260	8.0 x 260mm (15659 2)		260	200	1
HB08.0-310	8.0 x 310mm (16934 9)		310	200	1
HB08.0-460	8.0 x 460mm (15661 5)		460	400	1

SDS PLUS Bionic PRO



heller Bionic Pro SDS Plus Professional Drill Bits Continued...



Part No.	Description	mm	mm	mm	qty
HB10.0-110	10.0 x 110mm (16465 8)	10.0	110	50	1
HB10.0-160	10.0 x 160mm (15628 8)		160	100	1
HB10.0-210	10.0 x 210mm (15629 5)		210	150	1
HB10.0-260	10.0 x 260mm (15630 1)		260	200	1
HB10.0-460	10.0 x 460mm (15967 8)		460	400	1
HB10.0-600	10.0 x 600mm (17882 2)		600	550	1
HB10.0-1000	10.0 x 1000mm (19882 0)		1000	950	1
HB12.0-160	12.0 x 160mm (15631 8)	12.0	160	100	1
HB12.0-210	12.0 x 210mm (15632 5)		210	150	1
HB12.0-260	12.0 x 260mm (15633 2)		260	200	1
HB12.0-450	12.0 x 450mm (15969 2)		450	400	1
HB12.0-600	12.0 x 600mm (15970 8)		600	550	1
HB12.0-1000	12.0 x 1000mm (19883 7)		1000	950	1
HB13.0-160	13.0 x 160mm (18309 3)	13.0	160	100	1
HB13.0-250	13.0 x 250mm (18310 9)		250	200	1
HB14.0-250	14.0 x 250mm (15638 7)	14.0	250	200	1
HB14.0-450	14.0 x 450mm (16317 0)		450	400	1
HB14.0-600	14.0 x 600mm (15971 5)		600	550	1
HB14.0-1000	14.0 x 1000mm (19884 4)		600	550	1
HB15.0-160	15.0 x 160mm (17394 0)	15.0	160	100	1
HB15.0-200	15.0 x 200mm (15639 0)		200	150	1
HB15.0-250	15.0 x 250mm (15640 0)		250	200	1
HB16.0-160	16.0 x 160mm (15641 7)	16.0	160	100	1
HB16.0-200	16.0 x 200mm (15642 4)		200	150	1
HB16.0-250	16.0 x 250mm (16930 1)		250	200	1
HB16.0-300	16.0 x 300mm (18688 9)		300	250	1
HB16.0-450	16.0 x 450mm (15643 1)		450	400	1
HB16.0-600	16.0 x 600mm (159722)		1000	950	1
HB16.0-1000	16.0 x 1000mm (198851)		450	400	1
HB18.0-200	18.0 x 200mm (15644 8)	18.0	200	150	1
HB18.0-450	18.0 x 450mm (16709 3)		450	400	1
HB18.0-600	18.0 x 600mm (15974 6)		600	550	1
HB18.0-1000	18.0 x 1000mm (19886 8)		1000	950	1
HB20.0-200	20.0 x 200mm (15647 9)	20.0	200	150	1
HB20.0-300	20.0 x 300mm (18690 2)		300	250	1
HB20.0-450	20.0 x 450mm (15648 6)		450	400	1
HB20.0-600	20.0 x 600mm (15660 8)		550	600	1
HB20.0-1000	20.0 x 1000mm (19887 5)		1000	950	1
HB22.0-250	22.0 x 250mm (15649 3)	22.0	250	200	1
HB22.0-450	22.0 x 450mm (15650 9)		450	400	1
HB24.0-250	24.0 x 250mm (15651 6)	24.0	250	200	1
HB24.0-450	24.0 x 450mm (17247 9)		450	400	1
HB25.0-250	25.0 x 250mm (15652 3)	25.0	250	200	1
HB25.0-450	25.0 x 450mm (15653 0)		450	400	1
HB26.0-250	26.0 x 250mm (21935 8)	26.0	250	200	1
HB26.0-450	26.0 x 450mm (15654 7)		450	400	1

SDS PLUS Bionic PRO



DRILLING

heller Prefix SDS Plus Economy Range Drill Bits



Part No.	Description	mm	mm	mm	qty
HPR04.0-110	4.0 x 110mm (26837 0)	4.0	110	50	1
HPR04.0-160	4.0 x 160mm (25300 0)		160	100	1
HPR05.0-110	5.0 x 110mm (25301 7)	5.0	110	50	1
HPR05.0-160	5.0 x 160mm (25302 4)		160	100	1
HPR05.5-110	5.5 x 110mm (25303 1)	5.5	110	50	1
HPR05.5-160	5.5 x 160mm (25304 8)		160	100	1
HPR05.5-210	5.5 x 210mm (25305 5)		210	150	1
HPR06.0-110	6.0 x 110mm (25306 2)	6.0	110	50	1
HPR06.0-160	6.0 x 160mm (25307 9)		160	100	1
HPR06.0-210	6.0 x 210mm (25308 6)		210	150	1
HPR06.0-260	6.0 x 260mm (26838 7)		260	200	1
HPR06.5-160	6.5 x 160mm (25309 3)	6.5	160	100	1
HPR06.5-210	6.5 x 210mm (25310 9)		210	150	1
HPR07.0-110	7.0 x 110mm (25311 6)	7.0	110	50	1
HPR07.0-160	7.0 x 160mm (25312 3)		160	100	1
HPR07.0-210	7.0 x 210mm (25313 0)		210	150	1
HPR08.0-110	8.0 x 110mm (25314 7)	8.0	110	50	1
HPR08.0-160	8.0 x 160mm (25315 4)		160	100	1
HPR08.0-210	8.0 x 210mm (25316 1)		210	150	1
HPR08.0-260	8.0 x 260mm (25317 8)		260	200	1
HPR10.0-110	10.0 x 110mm (26839 4)	10.0	110	50	1
HPR10.0-160	10.0 x 160mm (25320 8)		160	100	1
HPR10.0-210	10.0 x 210mm (25321 5)		210	150	1
HPR10.0-260	10.0 x 260mm (25322 2)		260	200	1
HPR10.0-310	10.0 x 310mm (25323 9)		260	200	1
HPR10.0-450	10.0 x 450mm (26840 0)		450	400	1
HPR12.0-160	12.0 x 160mm (25325 3)	12.0	160	100	1
HPR12.0-210	12.0 x 210mm (25326 0)		210	150	1
HPR12.0-260	12.0 x 260mm (25327 7)		260	200	1
HPR12.0-310	12.0 x 310mm (25328 4)		310	250	1
HPR12.0-450	12.0 x 450mm (26841 7)		450	400	1
HPR14.0-210	14.0 x 210mm (25330 7)	14.0	210	200	1
HPR14.0-250	14.0 x 250mm (25331 4)		250	200	1
HPR14.0-310	14.0 x 310mm (25332 1)		310	250	1
HPR14.0-450	14.0 x 450mm (26842 4)		450	400	1
HPR16.0-160	16.0 x 160mm (25333 8)	16.0	160	100	1
HPR16.0-210	16.0 x 210mm (25334 5)		210	150	1
HPR16.0-300	16.0 x 300mm (25335 2)		300	250	1
HPR16.0-450	16.0 x 450mm (26843 1)		450	400	1
HPR18.0-260	18.0 x 260mm (26844 8)	18.0	260	200	1
HPR18.0-300	18.0 x 300mm (26845 5)		300	250	1
HPR18.0-450	18.0 x 450mm (26846 2)		450	400	1
HPR20.0-300	20.0 x 300mm (26847 9)	20.0	300	250	1
HPR20.0-450	20.0 x 450mm (26848 6)		450	400	1
HPR22.0-450	22.0 x 450mm (26849 3)	22.0	450	400	1
HPR25.0-450	25.0 x 450mm (26850 9)	25.0	450	400	1

SDS PLUS Prefix



Tile drilling made easy!

FEATURES

- Perfect results in the hardest of tiles, roofing tiles and stoneware.
- No cooling required - hard metal drill suitable for dry use.
- With tri-edge shank to stop rotation.
- Suitable for use in power drills.

EASY TO USE

- Start drilling with low pressure, after centralizing, continue to work with high pressure.
- Change to concrete drill once the tiles have been fully penetrated.
- Designed for rotational drilling only - NO IMPACT DRILLING.



heller Cera Expert



Part No.	Description	mm	qty
HCE05	Cera Expert 5mm (28674 9)	5.0	1
HCE06	Cera Expert 6mm (28675 6)	6.0	1
HCE08	Cera Expert 8mm (28676 3)	8.0	1
HCE10	Cera Expert 10mm (28677 0)	10.0	1



- No cooling required - diamond drill suitable for dry drilling.
- Diamond layer protected by an integrated paraffin emulsion (up to a diameter of 12 mm).
- Suitable for angle grinders with M14 collet at high rotational speeds.
- Change to concrete drill once tiles have been fully penetrated.



Part No.	Description	mm	qty
HCEHS06*	Ceramic Tile Drill Bit 6mm	6.0	1
HCEHS08*	Ceramic Tile Drill Bit 8mm	8.0	1
HCEHS10*	Ceramic Tile Drill Bit 10mm	10.0	1
HCEHS12*	Ceramic Tile Drill Bit 12mm	12.0	1
HCEHS14*	Ceramic Tile Drill Bit 14mm	14.0	1
HCEHS20	Ceramic Tile Drill Bit 20mm	20.0	1
HCEHS25	Ceramic Tile Drill Bit 25mm	25.0	1
HCEHS35	Ceramic Tile Drill Bit 35mm	35.0	1

* Self Lubricating



DRILLING

Enduro Chisel with "Self-Sharpening" effect

DURABLE. POWERFUL,
SELF-SHARPENING

- Increased lifetime with innovative chisel blade design and increased blade length.
- Reduces working time thanks to improved energy transfer.
- Reduced profile wear over the service life.
- Increases comfort by reducing vibrations.
- Maximum durability wear resistant material.
- Proprietary heat treated steel.



EnDuro chisel



Standard chisel



heller
get a bit more

heller EnDuro SDS MAX Points, Flat Chisels & Spade Chisels



HMAXCP350E



HMAXCS40E



HMAXCF20E



Part No.	Description	mm	mm	qty	qty
HMAXCP350E	Point 350mm Long (28545 2)	n/a	350	1	n/a
HMAXCF20E	20mm wide Flat Chisel 350mm Long (28546 9)	20	350	1	n/a
HMAXCS40E	40mm wide Spade Chisel 350mm Long (28547 6)	40	350	1	n/a

heller EnDuro SDS -Plus Points, Flat Chisels & Spade Chisels



HBCP14E



HBCF40E



HBCF20E



Part No.	Description	mm	mm	qty	qty
HBCP14E	5 Kant point (14mm) 250mm length (28542 1)	14	250	1	n/a
HBCF20E	20mm wide Flat Chisel 250mm (28543 8)	20	250	1	n/a
HBCS40E	40mm wide Spade Chisel 250mm long (28544 5)	40	250	1	n/a



heller SDS MAX Points, Flat Chisels & Spade Chisels

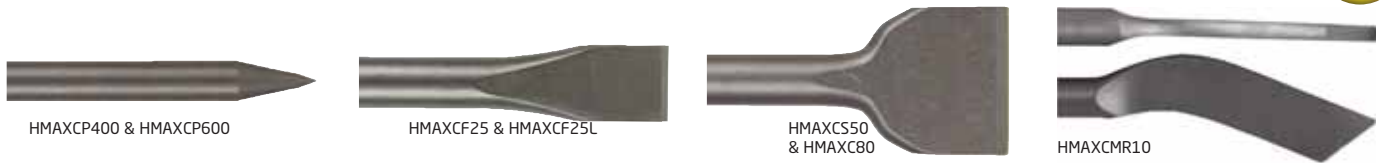

Part No.	Description	mm	mm	qty	qty
HMAXCP400	Point 400mm Long (21001 0)	n/a	400	1	n/a
HMAXCP600	Point 600mm Long (21002 7)	n/a	600	1	n/a
HMAXCF25	25mm wide Flat Chisel 400mm Long (21004 1)	25	400	1	n/a
HMAXCF25L	25mm wide Flat Chisel 600mm Long (21005 8)	25	600	1	n/a
HMAXCS50	50mm wide Spade Chisel 400mm Long (21006 5)	50	400	1	n/a
HMAXCS80	80mm wide Spade Chisel 300mm Long (21007 2)	80	300	1	n/a
HMAXCMR10	Mortar Rake 10mm X 30mm (21011 9)		300	1	n/a

heller SDS-Plus Points, Flat Chisels, Spade Chisels & Mortar Rake



Part No.	Description	mm	mm	qty
HBCP11	Round point (11mm) 250mm length (16114 5)	11	250	1
HBCP14	5 Kant point (14mm) 250mm length (19620 8)	14	250	1
HBCF20	20mm wide Flat Chisel 250mm (19621 5)	20	250	1
HBCS40	40mm wide Spade Chisel 250mm long (19622 2)	40	250	1

heller SDS-Plus Points, Flat Chisels, Spade Chisels & Mortar Rake



Part No.	Description	mm	mm	qty
HBCG22	Gouge Chisel (22mm) 250 Length (19623 9)	22	250	1
HBCM6	Mortar Chisel (6mm) 250 Length (19624 6)	6	250	1
HBCT	Tile Chisel (75mm x 125mm) 250 Length (19811 3)	75	250	1
HBCW22	Winged Chisel (22mm) 250 Length (22835 0)	22	250	1



DRILLING



heller HSS-Co Cobalt Twist Drills 25pc FOR THE TOUGHEST JOBS IN STAINLESS STEEL AND METAL



- For a large number of drill holes in high-alloy steel and stainless steel
- Split point and 135° point angle for optimum, extremely accurate starting
- Use of a special HSS steel with 5% cobalt
- Precision tool compliant with DIN 338 RN for outstanding hole dimensional accuracy
- High true-running accuracy to DIN 1414
- Includes the following sizes (mm)
1 / 1.5 / 2 / 2.5 / 3 / 3.5 / 4 / 4.5 / 5 / 5.5 / 6 / 6.5 / 7 / 7.5 / 8 / 8.5 / 9 / 9.5 / 10 / 10.5 / 11 / 11.5 / 12 / 12.5 / 13

- ✓✓✓ Sheet metal
- ✓✓✓ Non-ferrous metals
- ✓✓✓ CrNi steel
- ✓✓✓ Stainless steel
- ✓✓✓ Iron
- ✓✓✓ Cast
- ✓✓✓ Cast steel
- ✓✓✓ V2A Nirosta stainless steel, V4A

Metal



Part No.	Description	Set qty
HDBOX-HSSC025 (21965 5)	HSS-Co Cobalt Twist drill 25pc Maxx Box - DIN 338 RN	1



heller HSS-G Super Twist Drills 25pc THE BEST POINT FOR METAL



- Ideal for drilling in alloyed and unalloyed steels
- Precision point to DIN 338 RN for outstanding hole dimensional accuracy
- Split point and 135° point angle for optimum centering when starting
- High true-running accuracy to DIN 1414
- Includes the following sizes (mm)
1 / 1.5 / 2 / 2.5 / 3 / 3.5 / 4 / 4.5 / 5 / 5.5 / 6 / 6.5 / 7 / 7.5 / 8 / 8.5 / 9 / 9.5 / 10 / 10.5 / 11 / 11.5 / 12 / 12.5 / 13

- ✓✓✓ Sheet metal
- ✓✓ Non-ferrous metals
- ✓✓ CrNi steel
- ✓✓ Stainless steel
- ✓✓✓ Iron
- ✓✓✓ Cast
- ✓✓ Cast steel
- ✓ V2A Nirosta stainless steel, V4A

Metal



Part No.	Description	Set qty
HDBOX-HSSG25 (21964 8)	HSS-G SuperTwist drill 25pc Maxx Box - DIN 338 RN	1



heller HSS-R Twist Drills 25pc THE CLASSIC FOR SIMPLE SOLUTIONS IN METAL



- Ideal for drilling in unalloyed steels
- Web thinning with 118° point angle for long service life
- Reliable HSS drill with constant spiral hardness
- Precision tool to DIN 338 RN
- Includes the following sizes (mm)
1 / 1.5 / 2 / 2.5 / 3 / 3.5 / 4 / 4.5 / 5 / 5.5 / 6 / 6.5 / 7 / 7.5 / 8 / 8.5 / 9 / 9.5 / 10 / 10.5 / 11 / 11.5 / 12 / 12.5 / 13

- ✓✓✓ Sheet metal
- ✓✓ Non-ferrous metals
- ✓ CrNi steel
- ✓ Stainless steel
- ✓ Iron
- ✓✓ Cast
- ✓ Cast steel

Metal



Part No.	Description	Set qty
HDBOX-HSSR25 (18371 0)	HSS-R Twist drill 25pc Maxx Box - DIN 338 RN	1



heller CV Brad Points 10pce

THE CLASSIC FOR UNIVERSAL WOOD APPLICATIONS



- Exact starting and clean drill holes thanks to ground centre point and two spurs
 - Extra robust thanks to wear-resistant steel
 - Fast advance and chip removal in hardwood and softwood
 - Also suitable for use with cordless drills
- Includes the following sizes (mm)
3/4/5/6/7/8/9/10/11/12
- ✓✓✓ Beams
 - ✓✓✓ Laminated chip-board
 - ✓✓✓ Veneered wood
 - ✓✓✓ Hardwood
 - ✓✓ Shutter boards
 - ✓✓✓ Chipboard
 - ✓✓✓ Plywood
 - ✓✓ Cross-grain wood
 - ✓✓✓ Softwood

Wood

Part No.	Description	Set qty
HDBOX-CVBP10 (24646 0)	CV Brad Point 10pce Maxx Box	1

heller Bionic SDS Plus 7Pce

FAST & EFFECTIVE – NOT ONLY IN CONCRETE



- Long service life and low probability of breakage even on impact with reinforcements
- Tungsten carbide cutting edge with cutting tooth profile
- High drilling speed thanks to wide Twinmax spiral
- Optimum low-vibration drilling protects the user
- Certified by the Prüfgemeinschaft Mauerbohrer (PGM) in accordance with the requirements of the Deutsches Institut für Bautechnik (DIBt)



- Includes the following sizes (mm)
5 x 160mm
5.5 x 160mm
6 x 160mm
6.5 x 160mm
8 x 160mm
10 x 160mm
12 x 160mm
- ✓✓✓ Concrete
 - ✓✓ Concrete reinforcement
 - ✓✓✓ Gas concrete/YTONG
 - ✓✓ Granite
 - ✓✓✓ Sand-lime brick
 - ✓✓ Clinker
 - ✓✓✓ Aerated concrete
 - ✓✓ Marble
 - ✓✓✓ Brickwork
 - ✓✓✓ Stone

Concrete

Part No.	Description	Set qty
HDBOX-SDS7160 (28909 2)	SDS Plus Bionic 7pce Maxx Box	1

Follow Us





Facebook ICCONS Pty Ltd Instagram iccons.ptyltd LinkedIn ICCONS Pty Ltd





DRILLING

- ✓✓✓ Concrete
- ✓ Concrete reinforcement
- ✓✓✓ Gas concrete/YTONG
- ✓ Granite
- ✓✓✓ Sand-lime brick
- ✓✓✓ Clinker
- ✓✓✓ Aerated concrete
- ✓ Marble
- ✓✓✓ Brickwork
- ✓✓✓ Stone



NEW

heller Ratio Quick Core Bits GREAT DEPTHS – DRILLED QUICKLY AND CLEANLY

- Enhanced removal of dust thanks to alternating sequence of flat & pointed teeth
- Extremely robust and long service life
- Extremely quick advance thanks to edge-grinding of the drill hole
- Effective penetration even in reinforced concrete
- Length and diameter of the tool in the Ratio system can be freely configured



Part No.	Description	mm	mm	mm	qty
HCRCB050 (23391 0)	50mm Core Bit	50	80	105	1
HCRCB065 (23392 7)	65mm Core Bit	65	80	105	1
HCRCB080 (23394 1)	80mm Core Bit	80	80	105	1

heller Ratio Pilot Bit



HCRPB12 (10230 8)	12mm Pilot Bit			155	1
-----------------------------	----------------	--	--	-----	---

heller Ratio SDS Plus Adaptor



HCRSDSPUS (15547 2)	SDS Plus core ratio adaptor				1
-------------------------------	-----------------------------	--	--	--	---

heller Ratio SDS Max Adaptor



HCRSDSMAX (10243 8)	SDS Max adaptor				1
-------------------------------	-----------------	--	--	--	---



B+BTEC

Page



FB750W:

Angular Tile Drill for Ceramic Tile,
Natural Stone & Sanitary Ware

NEW



194



130BG:

Coring machine for up to 130mm core bits



196



300:

Coring machine for up to 300mm core bits



196



DCAF:

Auto Feed Attachment Suits 130BG & 300 machines



197



400:

Coring machine for up to 400mm core bits



198



Karat Coring Accessories

200



Diamond Core HiSPEED PRO Series
Segmented & Crown Bits

More Sizes



202



Diamond Core TRADE Series Bits



204



DIAMOND

KARAT FB750W



For up to 68mm bits

FB750W Powerful 750W

Angular Tile Drill for Ceramic Tile, Natural Stone & Sanitary Ware

- Accurate Chip Free cutting of the Hardest Tile & Stone
- For Wet Use with Premium Diamond Tile Bits up to 68 mm.
- Superior Drilling Speed
- Variable Speed

What's in the Box

- FB750W Angular Tile Drill
- GFCI Switch
- Adjustable Drilling Guide
- Water Supply Tank
- Ergonomic Side Grip
- Carrying Case
- Operating Manual



NEW

Part#	DTFB750W-KIT (200.026)
Power:	750w
Voltage:	230V
Frequency:	50Hz
No Load Speed	3,000 - 10,000 rpm
Bit Range:	Ø 4 - 68 mm
Weight:	2.6kg
Water Tank Volume:	5 Litres

Angular Tile Drill for Ceramic Tile, Natural Stone & Sanitary Ware



FB750W Accessories

	Part No.	Description	qty
A	DTBAWH	FB750W - Adapter to water hose (026.057) To connect the UDK to the water mains instead of the supplied water pressure tank. Recommended for larger bit diameters. Includes waterhose coupling.	1
B	DTBVSCC	FB750W - Cobra water slurry collector (210.0047) Attaches to wet vacuum to collect water & slurry	1





Premium Diamond Tile Bits

For Ceramic & Porcelain Tile, Glass, Natural Stone & Sanitary Ware



- Accurate Chip Free cutting of the Hardest Tile & Stone
- Silica Dust Free
- For Wet Use on FB750W and UDK68 Tile Drilling Systems
- Unparalleled Drilling Speed
- Diamond Height: 10 mm

Phenomenal Improvement in Drilling Performance

PREMIUM QUALITY Diamond Tile Bits offer the latest in Diamond Bit Technology and are unparalleled in Drilling Speed & Quality. Furthermore they offer an amazing Bit Life.

The range covers all common diameters from 4 mm up to 68 mm.

These Premium Quality Diamond Core Bits are an integral part of the Tile Drill system.

NEW



Part No.	Description	mm	qty
DTB004	Tile Bit Premium 4mm (4.000.504)	4	1
DTB005	Tile Bit Premium 5mm (4.000.505)	5	1
DTB006	Tile Bit Premium 6mm (4.000.506)	6	1
DTB008	Tile Bit Premium 8mm (4.000.508)	8	1
DTB010	Tile Bit Premium 10mm (4.000.510)	10	1
DTB012	Tile Bit Premium 12mm (4.000.512)	12	1
DTB013	Tile Bit Premium 13mm (4.000.513)	13	1
DTB014	Tile Bit Premium 14mm (4.000.514)	14	1
DTB016	Tile Bit Premium 16mm (4.000.516)	16	1
DTB018	Tile Bit Premium 18mm (4.000.518)	18	1
DTB020	Tile Bit Premium 20mm (4.000.520)	20	1
DTB024	Tile Bit Premium 24mm (4.000.524)	24	1
DTB026	Tile Bit Premium 26mm (4.000.526)	26	1
DTB028	Tile Bit Premium 28mm (4.000.528)	28	1
DTB032	Tile Bit Premium 32mm (4.000.532)	32	1
DTB035	Tile Bit Premium 35mm (4.000.535)	35	1
DTB040	Tile Bit Premium 40mm (4.000.540)	40	1
DTB045	Tile Bit Premium 45mm (4.000.545)	45	1
DTB051	Tile Bit Premium 51mm (4.000.551)	51	1
DTB060	Tile Bit Premium 60mm (4.000.560)	60	1
DTB068	Tile Bit Premium 68mm (4.000.568)	68	1



DIAMOND

KARAT® 130BG



For up to 130mm core bits

- LED Motor Overload Protection
- System.
- Water Levels aid the operator in keeping the machine level.
- 360° Auxiliary Handle.
- 3-Speed Gearing for optimal drilling.
- Performance at any Diameter.
- Powerful 2000W Drill Motor with PULSE Electronic Motor Protection.
- Professional Grade Aluminium Motor Housing.
- Water flow Indication.
- Back Grip Handle.
- Water Valve facing backwards to prevent damage.
- ½" - 1¼" combi spindle.
- Full Range of HiSpeed Diamond
- Core Bits.



Part#	DCTDK130BG
Power:	2000 W
Voltage / Frequency / Gears	230V / 50-60Hz / 3
Bit Range:	Ø 8 - 132 mm
Wet handheld drilling in concrete	Ø 8 - 40 mm
Dry handheld drilling in masonry	Ø 20 - 132mm
Rig mounted wet drilling in concrete	Ø 8 - 132 mm
Gear selection 1	Ø 55 - 132 mm - 900 rpm
Gear selection 2	Ø 25 - 60 mm - 2180 rpm
Gear selection 3	Ø 8 - 35mm - 4290 rpm
Spindle threading:	½" - 1 ¼"
Dimensions (L x W x H):	410 x 110 x 280 mm
Weight:	7,5 kg

See page 200-201 for coring accessories



Optional Drill Stand



With Optional Handle

Optional Auto feed attachment available see page 197

KARAT® 300



Faster Set-Up even Faster Drilling

- Protective motor brackets that double as handles.
- Powerful Drill Motors with PULSE™ Electronic Motor Protection System.
- Full range of HiSpeed diamond core bits .
- Water levels for easy machine set-up.
- Anchoring assembly.
- Engraved drilling depth indication
- Quick-release slide (Karat 300 only).
- Dovetail guide-way.
- Quick snap reversible downfeed spindle (left-right).
- Waterflow indicator.
- Column tiltable up to 45° for angle drilling.
- Transportation wheels
- LED motor overload protection system.
- 3-Speed gearing for optimal drilling performance at any diameter.
- Water valve.
- ½" - 1 ¼" combi spindle.
- Integrated centering device



Part#	DCTDK300
Voltage / Frequency / Power	230V / 50-60Hz / 2400W
Bit Range: [mm]	Ø 25 - 300
Drilling Depth: [mm]	Standard 400
Spindle Threading:	½" - 1 ¼"
Column Tilt-able:	Up to 45°
Weight: inc Stand [kg]	30
Dimensions (L x W x H): [mm]	530 x 275 x 775
Gear selection 1	Ø 120 - 300 mm - 450 rpm
Gear selection 2	Ø 60 - 150 mm - 900 rpm
Gear selection 3	Ø 25 - 80 mm - 1600 rpm

See page 200-201 for coring accessories



Optional Auto feed attachment available see page 197



KARAT® DCAF



Auto Feed Attachment Suits 130BG & 300 machines

- LED Display. Shows progress and drill depth
- Digital depth set & pressure adjustment
- Automatically regulates drilling pressure
- Automatic retraction when depth is achieved
- Through cycle setting
- Safety stop button
- Performance at any Diameter.
- Automatic pressure correction
- Light weight
- Easy setup and quick release attachment
- Professional Grade Aluminium Motor Housing.
- One lead power supply for both drill rig and auto feed attachment
- Provides more drilling meters per core bit
- One operator can simultaneously monitor more than one machine at one time saving \$\$\$\$ on labour
- Sturdy plastic carry case

NEW



Part#	DCASAF (2.000.237)
Voltage / Frequency / Power	250V / 50/60Hz / 60W
Dimensions (L x W x H):	115 x 220 x 480 mm
Weight:	8,5 kg
Safety Class (IP Code)	IP55

See page 200-201 for coring accessories



B+BTEC

AUTO FEED ATTACHMENT

ATTACHES TO THE 130BG OR 300 DRILL RIGS





KARAT® 400



For up to 400mm core bits

- Protective motor brackets that double as handles.
- Powerful Drill Motors with PULSE™ Electronic Motor Protection System.
- Water levels for easy machine set-up.
- Anchoring assembly.
- Engraved drilling depth indication
- Dovetail guide-way.
- Quick snap reversible downfeed spindle (left-right).
- Water flow indicator.
- Column tilttable up to 45° for angle drilling.
- Transportation wheels
- LED motor overload protection system.
- 3-Speed gearing for optimal drilling performance at any diameter.
- Water valve.
- 1 ¼" spindle.

Part#	DCTDK400
Voltage / Frequency / Power	230V / 50-60Hz / 2400W
Bit Range: [mm]	Ø 50 - 400
Drilling Depth: [mm]	Standard 400
Spindle Threading:	1 ¼"
Weight: Inc Stand [kg]	54
Dimensions (L x W x H): [mm]	800 x 380 x 1080
Gear selection 1	Ø 150 - 400 mm - 210 rpm
Gear selection 2	Ø 70 - 180 mm - 500 rpm
Gear selection 3	Ø 50 - 90 mm - 850 rpm

See page 200-201 for coring accessories

Professional Diamond Core Drilling Rig



Electronic Motor Protection - The Pulse™ Electronic Motor Protection System physically alerts the operator of an approaching motor overload by varying the rpm rate up to 6 times before shut down. The introduction of the Pulse System has resulted in increased machine & bit life and allows the operator to achieve optimal drilling speed at all times.



Motor Overload Protection - 7 bright LED's visually aid the operator at maintaining optimal bit feed pressure thus preventing motor overload and increasing drilling performance.



3-Speed Gearing - All our Karat® core drills are equipped with powerful drill motors and a 3-speed gear box for optimal drilling performance regardless of the bit diameter, concrete quality or amount of reinforcement.



Modular Design - The modular system design of the new Karat® core drilling machines gives the customer the freedom to configure his own drilling rig. Also it allows for the easy exchange of drill motors, stands and accessories on the job-site.



Data Retrieval Software - Karat® Drill Motors have an integrated data storage capability. Machine data such as operating hours and motor loading are saved. This data can easily be retrieved with the optional Karat® data software using a hi-speed USB connection (included in the software package).



Diamond Technology - B+BTec uses an advanced sintering technology for the manufacturing of the new HiSpeed diamond core bits. Together with the exclusive use of top quality diamond crystals this has resulted in unparalleled drilling speed and bit life in high strength and heavily reinforced concrete.





Twice the Holes

New HiSpeed Diamond Core Bits for High Strength & Heavily Reinforced Concrete

NEW HiSpeed	
B+BTec 1 st Generation	1.2 x
baseline	1.0 x

New HiSpeed Core Bits - Based upon some 40 years of experience & expertise in the design & manufacturing of diamond tools, the B+BTec engineers have developed a brand new line of HiSpeed diamond core bits. Together with the new Karat® Core Drilling Systems they form a combination that is very hard to match.



Unparalleled Drilling Speed - The HiSpeed diamond bits offer a fantastic drilling performance under any circumstance but the true nature of these bits is unleashed when drilling in high strength and heavily reinforced concrete. With drilling speeds more than doubling and often even tripling, the HiSpeed bits are unparalleled on the market today.



SinTec Diamond Technology - B+BTec has developed a New Advanced Sintering Technology called SinTec. The combination of SinTec Technology, the development of Special Bonds and the exclusive use of Top Quality Diamond Crystals has resulted in a unique range of HiSpeed Diamond Core Bits that guarantee an unparalleled Drilling Speed and Long Tool Life in a wide range of materials.



Thin Kerf Bit Design - The new HiSpeed bits, with a kerf thickness half that of most bits, require far less bit feed pressure, which allows for faster penetration. This lower feed pressure also permits down sizing the motor, column and base to achieve small lightweight rigs. Lightweight means faster set ups, which translates into more holes per day!



Quality Engineering - The new Karat® diamond core drilling rigs come with countless quality features to improve drilling performance, machine life & operator comfort. Features include a LED motor load monitoring system, a usb data retrieval option for operating hours and motor loading, protective brackets around the motor housing that double as handles, wheels for easy transportation.



Thin Kerf Diamond Bit Design

- Drilling through Reo - Easily
- Drill Faster
- More holes per hour





Karat Coring Accessories

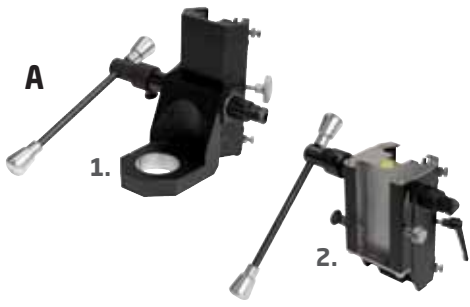

	Part No.	Description	qty
A	1. DCAQRS130	Karat 130 - Quick Release Slide (2.000.138) For Karat 130 Drill Motors. To be used on Drill Stands, Inc., dovetail guide-way, and reversible downfeed spindle.	1
	2. DCAQRS300	Karat 300 - Quick Release Slide (2.000.311) For Karat 300 Drill Motors. To be used on Drill Stand Large with wheels Inc. Quick release system, dovetail guide-way, water levels, and reversible downfeed spindle.	1
B	DCABGK130	Karat 130BG - Second Handle Back Grip (2.000.132) Additional Coated Aluminium Back Grip for Karat 130 BG. For operator comfort when drilling in Floor.	1
C	DCAC	Anchoring Assembly / Centerpen (2.100.009) For the fastening of the Karat Drill Stands Compact & Large. For use with ICCONS® M12 Drop-in Anchors. Use ICCONS 12 x 100 Thunderbolt Screw-bolts as Centerpen alternative.	1
D	DCART	Core Bit Rescue Tool (2.100.055) 475mm length For the retrieval of stuck core bits with 1¼" threading.	1
E	DCASK	Karat 130 Drill Stand Compact incl. Slide (2.000.131) includes slide (no wheels) Equipped with Dovetail Guide-Way, Centering Device, Depth Indication, Supplied with Anchoring Assembly. Weight excl. slide.: 9,5 kg, Drill depth 510mm	1
F	DCASKL	Drill Stand Large 700mm with wheels (2.000.304) , (slide not included) Max. Bit Diameter: Ø300 mm Karat 130: Drill depth 610mm Karat 300: Drill depth 580mm	1
	DCASKL1000	Drill Stand Large 1000mm (2.000.312) (slide not included) Equipped with Dovetail Guide-Way, Centering Device, Drilling Depth Indication and Transportation Wheels. Supplied with Anchoring Assembly. Max. Bit Diameter: Ø300 mm, Karat 130: Drill depth 1110mm, Karat 300 Drill depth 1080mm	1
	DCASKL1400	Drill Stand Large 1400mm (2.000.317) (slide not included) Equipped with Dovetail Guide-Way, Centering Device, Drilling Depth Indication and Transportation Wheels. Supplied with Anchoring Assembly. Max. Bit Diameter: Ø300 mm, Karat 130: Drill depth 1440mm, Karat 300 Drill depth 1410mm	1
G	DCHOSE2GO	Portable water supply 13.8 litre - constant pressure	1



Karat Coring Accessories



More than 50% weight reduction in comparison with standard rods.

	Part No.	Description	qty
H	DCVKS	Vacuum Kit Small (2.164.009) For the fastening of the Drill Stand Compact using a vacuum pump. Incl. Vacuum Rubber for the drill stand.	1
I	DCVKL	Vacuum Kit Large (2.250.011) For the fastening of the Drill Stand Large with Wheels using a vacuum pump. Incl. Pressure Gauge and Vacuum Rubber for the drill stand.	1
J	DCVP130/300	Vacuum Pump (2.100.002) For the fastening of the Karat Drill Stands. Requires Vacuum Kit.	1
K	DCK130WR10-66	KARAT 130BG - Water collector ring for a clean work area and overhead drilling Ø 10 - 66mm (2.000.145)	1
	DCK130WR50-131	Ø 50 -130mm (2.000.146)	1
	DCK130RC10-66	Rubber Cover for 10 - 66mm Water collector ring (6.506.031)	1
	DCK130RC50-131	Rubber Cover for 50 - 130mm Water collector ring (6.506.030)	1
L	DCER12300	Elongation Rods for greater drilling depths Length 300mm - ½" Min. Bit Diameter Ø 30mm (2.100.039)	1
	DCER12500	Length 500mm - ½" Min. Bit Diameter Ø 30mm (2.100.038)	1
	DCER114300	Length 300mm - 1¼" Min. Bit Diameter Ø 50mm (2.100.010)	1
	DCER114500	Length 500mm - 1¼" Min. Bit Diameter Ø 50mm (2.100.011) Ultra Light Weight	1
M	DCABI	Adapter to suit Hilti tools with BI fitting (6006122)	1
	DCABU	Adapter to suit Hilti tools with BU fitting (6006104)	1
N	DCAFF	Reducing adaptor 1 1/4 UNC Female to 1/2" BSP Female (6006102)	1
O	ZBBT-6005753	Blue rubber seal (6005753) Attaches to base of drill stands to create a vacuum seal when used with vacuum accessories.	1



Twice the Holes

B+BTEC PRO Series

NEW HiSpeed 2.6x

B+BTEC 1st Generation 1.2x

baseline 1.0x

Drilling Speed Comparison

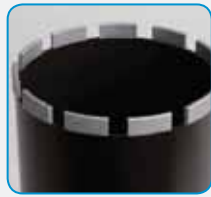

New **HiSpeed** Diamond Core Bits with **SiNTEC** Diamond Technology for High Strength & Heavily Reinforced Concrete.



B+BTEC Diamond Core HiSPEED PRO Series Crown Bits

For wet use - 1/2" bsp



Part No.	Description	mm	mm	qty
DCP010	Diamond Core PRO Series 10mm (2561015)	10	150	1
DCP012	Diamond Core PRO Series 12mm (2561215)	12	150	1
DCP014	Diamond Core PRO Series 14mm (2561440)	14	400	1
DCP015-150	Diamond Core PRO Series 15mm (2561515)	15	150	1
DCP015	Diamond Core PRO Series 15mm (2561530)	15	300	1
DCP016	Diamond Core PRO Series 16mm (2561640)	16	400	1
DCP018	Diamond Core PRO Series 18mm (2561840)	18	400	1
DCP018-750	Diamond Core PRO Series 18mm (2561875) NEW	18	750	1
DCP020	Diamond Core PRO Series 20mm (2562040)	20	400	1
DCP022	Diamond Core PRO Series 22mm (2562240)	22	400	1
DCP024	Diamond Core PRO Series 24mm (2562440)	24	400	1
DCP024-500	Diamond Core PRO Series 24mm (2562450) NEW	24	500	1
DCP024-750	Diamond Core PRO Series 24mm (2562475) NEW	24	750	1
DCP024-1000	Diamond Core PRO Series 24mm (25624100) NEW	24	1000	1
DCP025	Diamond Core PRO Series 25mm (2562540)	25	400	1
DCP026	Diamond Core PRO Series 26mm (2562640) NEW	26	400	1
DCP028	Diamond Core PRO Series 28mm (2562840) NEW	28	400	1
DCP028-500	Diamond Core PRO Series 28mm (2562850) NEW	28	500	1
DCP028-750	Diamond Core PRO Series 28mm (2562875) NEW	28	750	1
DCP028-1000	Diamond Core PRO Series 28mm (25628100) NEW	28	1000	1
DCP030	Diamond Core PRO Series 30mm (2563040) NEW	30	400	1
DCP030-750	Diamond Core PRO Series 30mm (2563075) NEW	30	750	1
DCP032	Diamond Core PRO Series 32mm (2563240)	32	400	1
DCP032-500	Diamond Core PRO Series 32mm (2563250) NEW	32	500	1
DCP032-750	Diamond Core PRO Series 32mm (2563275) NEW	32	750	1
DCP032-100	Diamond Core PRO Series 32mm (25632100) NEW	32	1000	1
DCP035	Diamond Core PRO Series 35mm (2563540)	35	400	1
DCP035-800	Diamond Core PRO Series 35mm (2563580)	35	800	1
DCP038	Diamond Core PRO Series 38mm (2563840)	38	400	1



DIAMOND

ICCONS®



B+BTEC Diamond Core HiSPEED PRO Series Segmented Bits

For wet use - 1-1/4" bsp



Part No.	Description		mm	mm	qty
DCP041	Diamond Core PRO Series 41mm (1904140)	NEW	41	400	1
DCP041-800	Diamond Core PRO Series 41mm (1904180)	NEW	41	800	1
DCP046	Diamond Core PRO Series 46mm (1904640)		46	400	1
DCP050	Diamond Core PRO Series 50mm (1905040)	NEW	50	400	1
DCP050-750	Diamond Core PRO Series 52mm (1905075)	NEW	50	750	1
DCP052	Diamond Core PRO Series 52mm (1905240)		52	400	1
DCP052-750	Diamond Core PRO Series 52mm (1905275)	NEW	52	750	1
DCP056	Diamond Core PRO Series 56mm (1905640)		56	400	1
DCP056-750	Diamond Core PRO Series 56mm (1905675)	NEW	56	750	1
DCP062	Diamond Core PRO Series 66mm (1906240)	NEW	62	400	1
DCP066	Diamond Core PRO Series 66mm (1906640)		66	400	1
DCP072	Diamond Core PRO Series 72mm (1907240)		72	400	1
DCP075	Diamond Core PRO Series 75mm (1907540)		75	400	1
DCP082	Diamond Core PRO Series 82mm (1908240)		82	400	1
DCP082-1000	Diamond Core PRO Series 82mm (19082100)	NEW	82	1000	1
DCP092	Diamond Core PRO Series 92mm (1909240)		92	400	1
DCP102	Diamond Core PRO Series 102mm (1910240)		102	400	1
DCP102-750	Diamond Core PRO Series 102mm (1910275)	NEW	102	750	1
DCP102-1000	Diamond Core PRO Series 102mm (19102100)	NEW	102	1000	1
DCP102-1500	Diamond Core PRO Series 102mm (19102150)	NEW	102	1500	1
DCP112	Diamond Core PRO Series 112mm (1911240)		112	400	1
DCP115	Diamond Core PRO Series 115mm (1911540)	NEW	115	400	1
DCP122	Diamond Core PRO Series 122mm (1912240)	NEW	122	400	1
DCP125	Diamond Core PRO Series 125mm (1912540)	NEW	125	400	1
DCP127	Diamond Core PRO Series 127mm (1912740)		127	400	1
DCP127-800	Diamond Core PRO Series 127mm (1912780)	NEW	127	800	1
DCP132	Diamond Core PRO Series 132mm (1913240)	NEW	132	400	1
DCP140	Diamond Core PRO Series 140mm (1914040)	NEW	140	400	1
DCP146	Diamond Core PRO Series 146mm (1914640)	NEW	146	400	1
DCP152	Diamond Core PRO Series 152mm (1915240)		152	400	1
DCP164	Diamond Core PRO Series 164mm (1916440)	NEW	164	400	1
DCP181	Diamond Core PRO Series 181mm (1918140)	NEW	181	400	1
DCP190	Diamond Core PRO Series 190mm (1919040)	NEW	190	400	1
DCP200	Diamond Core PRO Series 200mm (1920040)	NEW	200	400	1
DCP230	Diamond Core PRO Series 230mm (1923040)		230	400	1
DCP250	Diamond Core PRO Series 250mm (1925040)	NEW	250	400	1
DCP300	Diamond Core PRO Series 300mm (1930040)	NEW	300	400	1
DCP325	Diamond Core PRO Series 325mm (1932540)	NEW	325	400	1
DCP350	Diamond Core PRO Series 350mm (1935040)	NEW	350	400	1
DCP375	Diamond Core PRO Series 375mm (1937540)	NEW	375	400	1
DCP400	Diamond Core PRO Series 400mm (1940040)	NEW	400	400	1





RAPTOR[®]
TRADE
SERIES



Diamond Core TRADE Series Bits



For wet use - 1-1/4" bsp

Part No.	Description			
		mm	mm	qty
DCTR016	Diamond Core Trade Series 16mm	16	450	1
DCTR018	Diamond Core Trade Series 18mm	18	450	1
DCTR022	Diamond Core Trade Series 22mm	22	450	1
DCTR025	Diamond Core Trade Series 25mm	25	450	1
DCTR028	Diamond Core Trade Series 28mm	28	450	1
DCTR032	Diamond Core Trade Series 32mm	32	450	1
DCTR035	Diamond Core Trade Series 35mm	35	450	1
DCTR038	Diamond Core Trade Series 38mm	38	450	1
DCTR046	Diamond Core Trade Series 46mm	46	450	1
DCTR052	Diamond Core Trade Series 52mm	52	450	1
DCTR056	Diamond Core Trade Series 56mm	56	450	1
DCTR066	Diamond Core Trade Series 66mm	66	450	1
DCTR072	Diamond Core Trade Series 72mm	72	450	1
DCTR075	Diamond Core Trade Series 75mm	75	450	1
DCTR082	Diamond Core Trade Series 82mm	82	450	1
DCTR092	Diamond Core Trade Series 92mm	92	450	1
DCTR102	Diamond Core Trade Series 102mm	102	450	1
DCTR112	Diamond Core Trade Series 112mm	112	450	1
DCTR127	Diamond Core Trade Series 127mm	127	450	1
DCTR152	Diamond Core Trade Series 152mm	152	450	1
DCTR230	Diamond Core Trade Series 230mm	230	450	1



**Ask your ICCONS[®] representative
how to get your Diamond stand.**





CUSTOM CORES AVAILABLE



B+BTEC



Blade Selection Guide

- = Excellent
- = Good
- Not suitable

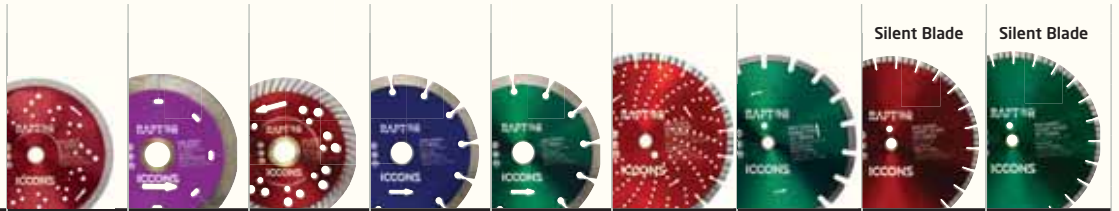

For best performance in these materials	IT	ICR	ITT	ISG	IASG	IDEMOCC	IADEMO	ISHC	ISB
Asphalt	--	--	--	--	●	--	●	--	--
Bluestone	●	--	--	●	--	●	--	--	--
Bricks - Concrete	●	--	--	●	--	●	--	--	●
Bricks - Hard Clay	●	--	--	●	--	●	--	●	--
Fibre Cement Sheet	●	●	●	●	●	●	●	--	--
Ceramic Tiles	●	●	●	--	--	--	--	--	--
Concrete Block / Besser	●	--	--	●	●	●	●	--	●
Concrete Reinforced	●	--	--	●	--	●	--	--	--
Concrete Green	--	--	--	--	●	--	●	--	--
Fibre Glass	●	●	●	●	--	●	--	--	--
Fire Brick	●	--	--	●	●	●	●	--	●
Granite	●	●	●	●	--	●	--	--	--
Hebel Block	●	--	--	●	●	●	●	--	●
Marble	●	●	●	●	--	--	--	--	--
Mortar joints	--	--	--	--	●	--	●	--	--
Porcelain	--	●	●	--	--	--	--	--	--
Roof Tiles Concrete	●	--	--	●	●	●	●	--	●
Roof Tiles Terracotta	●	--	--	●	●	●	●	●	--
Sandstone	--	--	--	--	●	--	●	--	●
Slate	●	--	--	●	●	●	●	●	--
Steel Pipe / Tube	●	--	--	--	--	●	--	--	--
Wall Chasing Clay Bricks	●	--	--	●	--	●	--	--	--
Wall Chasing Concrete	●	--	--	●	●	●	●	--	--
Wall Chasing Rendered	●	--	--	●	●	●	●	--	--
Page:	207	207	208	208	209	210	210	211	211

Concrete block blade suitable for concrete block / concrete roof tiles / hebel / sandstone / firebricks
 Hard clay blade suitable for hard bricks / clay pavers / terracotta roof tiles / bluestone / granite / slate

Range of grinding cups on page 212- 213





RAPTOR® Turbo Rim Blades Multi Use - For Non-Abrasive Material

Suitable for: Cured Concrete / Reinforced, Clay Bricks, Terracotta Roof Tiles, Granite, Bluestone, Steel Pipe / Tube & Hebel Block.

- Raised boss for superior strength and grip behind Flanges.
- Permanent Directional arrow cut out .
- High concentration of quality diamonds.
- Additional Cooling Holes to aid cooling of blade.
- Aggressive contoured segment for fast removal of material.
- Long life in non-abrasive material.
- Bore resize bushes - Press fit.
- 10mm high segment on blades up to 7" / 178mm.
- 12mm high segment on 9" / 230mm blade.
- Wet / Dry use.

Part No.	Description					
		Inches	mm	mm	qty	qty
IT100	For non abrasive substrates	4	105	16 / 20 / 22.2	1	5
IT115	For non abrasive substrates	4.5	115	22.2	1	5
IT125	For non abrasive substrates	5	125	22.2	1	5
IT178	For non abrasive substrates	7	178	20 / 22.2	1	5
IT230	For non abrasive substrates	9	230	22.2 / 25.4	1	5

Not recommended for abrasive materials such as green concrete, asphalt, cement block etc. as extreme premature wear will occur. See selection chart on page 206 for detailed compatibility.



RAPTOR® Continuous Rim Blades Porcelain / Ceramic Tiles

Suitable for: Porcelain, Ceramic Tiles, Marble, Granite, Vitrified Tiles, Glazed Tiles, Slate.

- Ultra-thin fast cut blade.
- Continuous rim - less chipping.
- Expansion slots for better cooling.
- 10mm segment height.
- High concentration of quality diamonds.
- Long life in non-abrasive material.
- Bore resize bushes - Press fit.
- Permanent Directional arrow cut out.
- Wet / Dry use.

Part No.	Description					
		Inches	mm	mm	qty	qty
ICR100	Suitable for Porcelain, ceramic & marble	4	105	16 / 20 / 22.2	1	5
ICR125	Suitable for Porcelain, ceramic & marble	5	125	22.2	1	5
ICR200	Suitable for Porcelain, ceramic & marble	8	200	22.2	1	5

Not recommended for abrasive materials such as green concrete, asphalt, cement block etc. as extreme premature wear will occur. See selection chart on page 206 for detailed compatibility.



DIAMOND



RAPTOR® Turbo Rim Thin Series Ceramic / Porcelain Tiles

Suitable for: Porcelain, Ceramic Tiles, Marble, Granite, Vitrified Tiles, Glazed Tiles, Slate.

- Ultra-thin Turbo fast cut blade.
- Raised boss for superior strength and grip behind - Flanges.
- 10mm segment height.
- High concentration of quality diamonds.
- Turbo design for superior cooling.
- Long life in non-abrasive material.
- Bore resize bushes - Press fit.
- Permanent Directional arrow cut out.
- Wet / Dry use



Part No.	Description	Inches	mm	mm	qty	qty
ITT100	Suitable for Porcelain, ceramic & marble	4	105	16 / 20 / 22.2	1	5
ITT125	Suitable for Porcelain, ceramic & marble	5	125	22.2	1	5

Not recommended for abrasive materials such as green concrete, asphalt, cement block etc. as extreme premature wear will occur. See selection chart on page 206 for detailed compatibility.



RAPTOR® Segmented Blades WALL CHASING.

For Non-Abrasive Material

Suitable for: Cured Concrete / Reinforced, Clay Bricks, Terracotta Roof Tiles, Bluestone, Slate.

- 10mm segment height.
- High concentration of quality diamonds.
- Long life in non-abrasive material.
- Fast cutting.
- Bore resize bushes - Press fit.
- Permanent Directional arrow cut out.
- Wet / Dry use.



Part No.	Description	Inches	mm	mm	qty	qty
ISG125	For non abrasive substrates	5	125	22.2	1	5
ISG150	For non abrasive substrates	6	150	20 / 22.2	1	5
ISG230	For non abrasive substrates	9	230	22.2 / 25.4	1	5

Not recommended for abrasive materials such as green concrete, asphalt, cement block etc. as extreme premature wear will occur. See selection chart on page 206 for detailed compatibility.



RAPTOR® Segmented Blades WALL CHASING.

For Abrasive Material

Suitable for: Green Concrete, Compressed Sheet, Concrete Block, Wall Chasing (Abrasive), Concrete Roof Tiles, Mortar Joints, Sandstone, Light Weight Concrete, Hebel Block.

- 10mm segment height.
- High concentration of quality diamonds.
- Long life in abrasive material.
- Fast cutting.
- Bore resize bushes - Press fit.
- Permanent Directional arrow cut out.
- Wet / Dry use.



Part No.	Description	Inches	mm	mm	qty	qty
IASG100	For abrasive substrates	4	105	16 / 20 / 22.2	1	5
IASG125	For abrasive substrates	5	125	22.2	1	5
IASG150	For abrasive substrates	6	150	20 / 22.2	1	5
IASG178	For abrasive substrates	7	178	20 / 22.32	1	5
IASG230	For abrasive substrates	9	230	22.2 / 25.4	1	5

Not recommended for non-abrasive materials such as cured concrete, bluestone, clay bricks etc. blade will not remain sharp in these materials. See chart page 206 for detailed compatibility





DIAMOND



RAPTOR® Demolition Blades For Non-Abrasive Material

LASER WELDED.

Suitable for: Cured Concrete / Reinforced, Clay bricks.

- 12mm segment height.
- High concentration of quality diamonds.
- Long life in non-abrasive material.
- Fast cutting.
- Bore resize bushes - Press fit.
- Permanent directional arrow cut out.
- Laser welded segments.
- Wet / Dry use.



Part No.	Description	Inches	mm	mm	qty	qty
IDEMOCC300	Segmented Demolition Blade for non-abrasive substrates	12	300	20 / 25.4	1	10
IDEMOCC350	Segmented Demolition Blade for non-abrasive substrates	14	350	20 / 25.4	1	10
IDEMOCC405	Segmented Demolition Blade for non-abrasive substrates	16	405	20 / 25.4	1	5

Not recommended for abrasive materials such as green concrete, asphalt, cement block etc. as extreme premature wear will occur. See selection chart on page 206 for detailed compatibility.



RAPTOR® Demolition Blades For Abrasive Material

LASER WELDED.

Suitable for: Green Concrete, Asphalt, Concrete Block, Mortar Joints, Sandstone.

- 12mm segment height.
- High concentration of quality diamonds.
- Long life in abrasive material.
- Fast cutting.
- Bore resize bushes - Press fit.
- Permanent directional arrow cut out.
- Dropped segment for undercut protection.
- Laser welded segments.
- Wet / Dry use



Part No.	Description	Inches	mm	mm	qty	qty
IADEMO300	Segmented Demolition Blade for abrasive substrates	12	300	20 / 25.4	1	10
IADEMO350	Segmented Demolition Blade for abrasive substrates	14	350	20 / 25.4	1	10
IADEMO405	Segmented Demolition Blade for abrasive substrates	16	405	20 / 25.4	1	5

Not recommended for non-abrasive materials such as cured concrete, bluestone, clay bricks etc. blade will not remain sharp in these materials. See chart on page 206 for detailed compatibility.



RAPTOR® Noise Reduced 'Silent' Blade For Hard Clay & Pavers

The noised reduced blades are designed to cut fast, smooth and minimise noise disturbance to the operator and surrounding area.

- Suitable for: Hard Clay Bricks & Pavers.
- 12mm segment height.
- High concentration of quality diamonds.
- Long life in non-abrasive material.
- Fast cutting.
- Bore resize bushes - Press fit.
- Wet / Dry use.

Part No.	Description	 Inches	 mm	 mm	 qty	 qty
ISHC350	Silent Blade for Hard Clay & Pavers	14	350	20 / 25.4	1	10

Not recommended for abrasive materials such as green concrete, asphalt, cement block etc. as extreme premature wear will occur. See selection chart on page 206 for detailed compatibility



RAPTOR® Noise Reduced 'Silent' Blade For Concrete Blocks

The noised reduced blades are designed to cut fast, smooth and minimise noise disturbance to the operator and surrounding area.

- Suitable for: Concrete Block.
- 12mm segment height.
- High concentration of quality diamonds.
- Long life in abrasive material.
- Fast cutting.
- Bore resize bushes - Press fit.
- Wet / Dry use.

Part No.	Description	 Inches	 mm	 mm	 qty	 qty
ISB350	Silent Blade for Concrete Blocks	14	350	20 / 25.4	1	10

Not recommended for non-abrasive materials such as cured concrete, bluestone, clay bricks etc. blade will not remain sharp in these materials. See chart on page 206 for detailed compatibility.



DIAMOND

RAPTOR® Single Row Grinding Cups



For Non-Abrasive Material

Suitable applications: Cured Concrete / Reinforced, Clay Bricks, General Masonry Products.

- Single row.
- Designed for flat grinding.
- Ideal for removal of concrete imperfections.
- Long life in non-abrasive material.
- Dry grinding.



Part No.	Description	Inches	mm	mm	qty	qty
IGSR100	Grinding Cup For Concrete	4	100	16 / 22.2	1	25
IGSR115	Grinding Cup For Concrete	4.5	115	22.2	1	25
IGSR125	Grinding Cup For Concrete	5	125	22.2	1	25
IGSR178	Grinding Cup For Concrete	7	178	22.2	1	10

Not recommended for abrasive materials such as green concrete, asphalt, cement block etc. as extreme premature wear will occur

RAPTOR® Double Row Grinding Cups



For Non-Abrasive Material

Suitable applications: Ideal for removal of concrete imperfections, trimming of concrete after removal of formwork, Cured Concrete / Reinforced, Clay Bricks, General Masonry Products.

- Double row.
- Long life in non-abrasive material.
- Smooth finish.
- Designed for flat grinding.
- Dry grinding.



Part No.	Description	Inches	mm	mm	qty	qty
IGDR100	Grinding Cup For Concrete	4	100	16 / 22.2	1	25
IGDR115	Grinding Cup For Concrete	4.5	115	22.2	1	25
IGDR125	Grinding Cup For Concrete	5	125	22.2	1	25
IGDR178	Grinding Cup For Concrete	7	178	22.2	1	10

Not recommended for abrasive materials such as green concrete, asphalt, cement block etc. as extreme premature wear will occur.



RAPTOR® Radial Grinding Cups

For Non-Abrasive Material

Suitable applications: Removal of paint and / or glue from concrete surface, ideal for removal of concrete imperfections, Cured Concrete / Reinforced, Clay Bricks, General Masonry Products.

- Fast stripping of paint / glue from concrete.
- No clogging.
- Long life in non-abrasive material.
- Dry grinding.



Part No.	Description	Inches	mm	mm	qty	qty
IGR100	Grinding Cup For Concrete	4	100	16 / 22.2	1	25
IGR115	Grinding Cup For Concrete	4.5	115	22.2	1	25
IGR125	Grinding Cup For Concrete	5	125	22.2	1	25
IGR178	Grinding Cup For Concrete	7	178	22.2	1	10

Not recommended for abrasive materials such as green concrete, asphalt, cement block etc. as extreme premature wear will occur

RAPTOR® Turbo Style Grinding Cups

For Non-Abrasive Material

Suitable applications: Perfect for shaping concrete / stone, ideal for removal of concrete imperfections, Cured Concrete / Reinforced, Pavers, Clay Bricks, General Masonry Products.

- Turbo style segment.
- Double layer for better cooling.
- Long life in non-abrasive material.
- Dry grinding.



Part No.	Description	Inches	mm	mm	qty	qty
IGT100	Grinding / Shaping Cup For Pavers, Concrete etc	4	100	16 / 22.2	1	25
IGT115	Grinding / Shaping Cup For Pavers, Concrete etc	4.5	115	22.2	1	25
IGT125	Grinding / Shaping Cup For Pavers, Concrete etc	5	125	22.2	1	25
IGT178	Grinding / Shaping Cup For Pavers, Concrete etc	7	178	22.2	1	10

Not recommended for abrasive materials such as green concrete, asphalt, cement block etc. as extreme premature wear will occur.



TOOLS

INDUSTRIAL QUALITY POWER TOOLS FOR DRILLING CUTTING & GRINDING





Battery Operated Tools

Page

18V KITS: Hammer Drill, Rotary Hammer Drill, Impact driver / wrench & collated screw-gun 216 - 217

18V Skins: Hammer Drill, Rotary Hammer Drill, Impact drivers/ wrench, Multi-tool, Grinder, Circular Saw, Jigsaw, Blower & Torch 218 -221

18V 5.0Ah Battery & Starter Kit & Carry Bag 223

Corded tools

Page

Circular Saw & Cut off Saw 224

Rotary Hammer Drills 2kg, 3kg & 5kg 225

Grinders 4", 5" & 9" 226 -227





Keyang specialise in manufacturing and selling D.C. motors for electric tools and major car electrical components.

The Keyang power tool side of the business began in 1977, Keyang now have more than 120 different tools, corded and cordless. ICCONS have selected a range to accommodate the anchoring, drilling & cutting. Though the Keyang Brand is reasonably young in Australia it has already established itself as a professional brand manufacturer in the international market.

Keyang values have remained true - To manufacture high quality industrial power tools without compromise.



DM18BL



18V Brushless Hammer Drill

- New compact design brushless hammer drill.
- Brushless motor gives you longer run time and better performance.
- Ergonomic soft grip handle provides comfort and balance to the user.
- 13mm heavy duty metal keyless chuck.
- Robust carry case.



Battery size / type	2 x 5.0 Ah Li-Ion
Weight (with battery)	1.9kg
No Load Speed (rpm)	0~550 / 2,000
Chuck - Keyless	1-13 mm
Max Torque (Drill Position)	60 Nm
Charging Time	40 min
Battery size	5.0 Ah
Capacity	Concrete: Ø 13 mm Mild Steel: Ø 13 mm Soft Wood: Ø 32 mm

Tool only skin also available see page 218

ID18BL



18V Brushless Impact Driver

- New compact design brushless impact driver.
- Brushless motor gives you longer run time and better performance.
- Ergonomic soft grip handle provides comfort and balance to the user.
- Robust carry case.



Battery size / type	2 x 5.0 Ah Li-Ion
Weight (with battery)	1.7kg
No Load Speed (rpm)	0~1,300 / 2,200 / 3,000
Tool holder	1/4" internal hex
Max Torque (Drill Position)	180 Nm
Charging Time	40 min
Battery size	5.0 Ah

Tool only skin also available see page 218



DW18BL



18V Brushless Dual Impact Tool (1/4" & 1/2")

- All-in-one impact driver and impact wrench with a 1/4" quick-change hex and a 1/2" square drive chuck for sockets
- New compact design brushless impact tool.
- Overload protection, Electronic current control reinforces product durability
- Compact design, Soft-grip and Built-in LED



Battery size / type	2 x 5.0 Ah Li-Ion
Weight (with battery)	1.7kg
No Load Speed (rpm)	0~1,300 / 2,200 / 3,000
Tool holder	1/4" int hex & 1/2" ext socket
3 speed Torque setting	SDS Plus
	1 60Nm - 70Nm
	2 110Nm - 120Nm
	3 170Nm - 180Nm
Charging Time	50 min

Tool only skin also available see page 219

2 IN 1 DUAL IMPACT TOOL (1/4" & 1/2")



HD18BL



18V Brushless Rotary Hammer Drill

- New brushless rotary hammer.
- 3 modes that allows you to drill, hammer drill and chisel.
- Compact design that is great for overhead work due to the lightweight design.
- Robust carry case.



Battery size / type	2 x 5.0 Ah Li-Ion
Weight (with battery)	3.1kg
Impact force	2.0 Joules
No Load Speed (rpm)	0~1,200
No Load Speed (bpm)	0~4,217
Chuck Type	SDS Plus
Charging Time	50 min
Capacity	Concrete: Ø 20mm

Tool only skin also available see page 220

ASD-1800L



18V Collated Drywall Screw Gun

- Lightest collated screwdriver on the market at only 1.1kg.
- Remove the collated magazine and tool turns into a cordless screwdriver.
- Runs 20-57mm collated screws.
- Battery indicator that gives status of charge.
- Robust carry case.



Battery size / type	2 x 5.0 Ah Li-Ion
Weight (with battery)	1.1kg
No Load Speed (rpm)	0~550 / 2,000
Chuck - Keyless	1-13 mm
Max Torque (Drill Position)	60 Nm
Charging Time	40 min
Battery size	5.0 Ah
Capacity	Concrete: Ø 13 mm
	Mild Steel: Ø 13 mm
	Soft Wood: Ø 32 mm



DM18BL-NT SKIN



18V Brushless Hammer Drill

- New compact design brushless hammer drill.
- Brushless motor gives you longer run time and better performance.
- Ergonomic soft grip handle provides comfort and balance to the user.
- 13mm heavy duty metal keyless chuck.
- Buy as a skin or in a kit combination.



Weight (without battery)	1.2kg
No Load Speed (rpm)	0~550 / 2,000
Chuck - Keyless	1-13 mm
Max Torque (Drill Position)	60 Nm
Capacity	Concrete: Ø 13 mm Mild Steel: Ø 13 mm Soft Wood: Ø 32 mm

Also available in kit with 2 x 5.0Ah bat & fast charger see page 216

ID18BL-NT SKIN



18V Brushless Impact Driver

- New compact design brushless impact driver.
- Brushless motor gives you longer run time and better performance.
- Ergonomic soft grip handle provides comfort and balance to the user.
- Buy as a skin or in a kit combination.



Weight (without battery)	1.1kg
No Load Speed (rpm)	0~1,300 / 2,200 / 3,000
Tool holder	1/4" internal hex
Max Torque	180 Nm

Also available in kit with 2 x 5.0Ah bat & fast charger see page 216



Brushless motors offer:

- High power to weight ratio
- High speed
- Increased efficiency (more torque per watt)
- Increased reliability
- Reduced noise
- Longer period of use between charging batteries



DW18BL-NT SKIN



18V Brushless Dual Impact Tool (1/4" & 1/2")

- All-in-one impact driver and impact wrench with a 1/4" quick-change hex and a 1/2" square drive chuck for sockets
- New compact design brushless impact tool.
- Overload protection, Electronic current control reinforces product durability
- Compact design, Soft-grip and Built-in LED



Weight (with battery)	1.7kg
No Load Speed (rpm)	0~1,300 / 2,200 / 3,000
Tool holder	1/4" int hex & 1/2" ext socket
3 speed Torque setting	SDS Plus
	1 60Nm - 70Nm
	2 110Nm - 120Nm
	3 170Nm - 180Nm

Also available in kit with 2 x 5.0Ah bat & fast charger see page 217

2 IN 1 DUAL IMPACT TOOL (1/4" & 1/2")



[1/4" Impact Driver]

[1/2" Impact Wrench]

IW18BL-H-NT SKIN



18V Brushless 1/2" High Torque

- Max. tightening torque of 1,000 Nm.
- Overload protection, Electronic current control reinforces product durability.
- Compact design for maximum comfort and less fatigue.
- Soft start function prevents wrist injuries.
- Suitable for heavy duty work and engineering applications



1,000 Nm



Weight (without battery)	2.6kg
No Load Speed (rpm)	0~2,000
Max Torque	1000 Nm
Tool holder	1/2" (Pin Detent)
Size (L x W x H) (with battery)	224 x 85 x 264mm

NEW

IW18BL-NT SKIN



18V Brushless 1/2" Impact Wrench

- Max. Tightening torque of 270 Nm.
- 3 Stage impact power selection.
- Auto stop system provides better and effective operation in unfastening a bolt
- Overload protection, Electronic current control reinforces product durability.
- Compact design, Soft-grip & Built-in L.E.D



270 Nm



Weight (without battery)	1.1kg
No Load Speed (rpm)	0~1,100 / 1,800 / 2,400
Max Torque	270 Nm
Tool holder	1/2" (Pin Detent)
Size (L x W x H) (with battery)	148 x 63 x 242mm

NEW



TOOLS

HD18BL-NT SKIN



18V Brushless Rotary Hammer Drill

- Efficient brushless DC motor provides higher productivity.
- Overload protection, Electronic current control reinforces motor durability
- Compact lightweight design that is great for overhead work.



Weight (without battery)	2.4kg
Impact force	2.0 Joules
No Load Speed (rpm)	0~1,200
No Load Speed (bpm)	0~4,217
Chuck Type	SDS Plus
Capacity	Concrete: Ø 20mm
Size (L x W x H) (without battery)	290 x 80 x 205mm

Also available in kit with 2 x 5.0Ah bat & fast charger see page 217

MC18BL-NT SKIN



18V Brushless Oscillating Multi-Tool

- Tool free accessory lever for quick installation & replacement
- Lock on/off function for continuous work and user safety
- Dual variable trigger

NEW



Weight (without battery)	1.5kg
No Load Speed (rpm)	0~19,500
Vibration Angle	1.6° (Total 3.2°)
Size (L x W x H) (without battery)	335 x 75 x 110mm

Accessories include:

- | | |
|--|--|
| a. 1 x 95mm Circular cutting blade (wood/ soft metal/ plastic) | f. 1 x 52mm scraping blade |
| b. 1 x 85mm Tile grout removal blade | g. 1 x Sanding pad |
| c. 1 x 10mm flush cut blade (wood/plastic) | h. 6 x Sand paper (3 x P60 / 3 x P120) |
| d. 1 x 35mm flush cut blade (wood/plastic) | |
| e. 1 x 35mm flush cut blade (wood/ metal/ plastic) | |

RS18L-0-NT SKIN



18V Reciprocating Saw

- Ergonomic handle, One-handed design
- Low Vibration.
- One touch blade holder.
- Adjustable foot.
- Compatible with jigsaw blades.
- Overload protection.
- Built-in LED.



NEW

Weight (without battery)	1.75kg
Stroke per Minute (spm)	0~3,400
Stroke	19mm
Max Cutting Capacity	50mm (wood)
Size (L x W x H)	341 x 77 x 175mm

DG18BL-125S-NT SKIN



18V Cordless Angle Grinder

The perfect tool for any tradies

- tool bag.
- 4 pole motor delivers great power when cutting or grinding.
- Great tool to for those tight spaces with the advantage of no leads.
- Restart protection.



Weight (without battery)	0.9kg
No load speed (rpm)	10,000
Max. Dia	Ø 125 mm
Spindle size	M14
Size (L x W x H) (without battery)	281 x 76 x 95mm



CS-1800-NT SKIN



18V Circular Saw

- Lightweight and compact saw that delivers optimum power.
- Ergonomically designed with soft grip handle making it extremely comfortable for the user.
- Blade is on the right hand side unlike other cordless models on the market.
- Excellent visibility of cutting line.



Weight (without battery)	2.4 kg
No Load Speed (rpm)	4000
Cutting depth 90°	57
Cutting depth 50°	36
Cutting depth 45°	40
Max. Blade Ø	165 mm
Size (L x W x H) (with battery)	300 x 205 x 180mm

BR18L-NT Skin



18v Blower



NEW



Weight (without battery)	1.28 kg
Max Air Volume (m³ rpm)	3.0
Max Air Velocity (m/s)	80
No Load Speed (rpm)	20,000
Size (L x W x H) (without battery)	500 x 155 x 155mm

JS-1800L-NT SKIN



18V Jigsaw

- 3 stage pendulum action enables user to select how aggressive he wants to cut.
- Changing blades made easy with quick release system.
- Great visibility when cutting due to the motor creating air that clears the line of cut.
- Variable speed on the trigger.



Weight (without battery)	3.2 kg
No Load Speed (bpm)	0-2,600
Cutting Depth	Wood - 85 mm
	Steel - 6 mm
Size (L x W x H) (without battery)	230 x 75 x 215mm

LF1418Z-NT SKIN



18V Cordless L.E.D. Worklight

- Angle adjustment up to 90 degrees.
- 9 energy efficient L.E.D lights provides maximum battery life.
- 3 steps of angle adjustment.



Weight (with battery)	0.6 kg
Nominal voltage	14.4 / 18 DC V
LED light	9 Bulbs LED
Functions	Head pivots 90°
Functions	Handle pivots 130°
Size (L x W x H) (without battery)	120 x 75 x 240mm



18V
LITHIUM
Long Life **Li-ION**

BL DC MOTOR



P220

BL DC MOTOR



P218

BL DC MOTOR



P218

BL DC MOTOR



P220

Coming Soon
P220



P220

BL DC MOTOR



P219



P221

BL DC MOTOR



P219



P221

BL DC MOTOR



P219



P221

P217



BL DC MOTOR



P217

BL DC MOTOR



P217

BL DC MOTOR



P216

BL DC MOTOR



P216



P221

BL DC MOTOR



P220

SKINS

SKINS

KITS INCLUDE 2 X BATTERIES

Create your
Combo





K-18VS-5



18V Keyang Starter Pack 5.0Ah



5.0 Ah

- Purchase a starter kit to get your Keyang system started.
- Compatible with all Keyang cordless 18v tools.
- 2 x 5Ah batteries.
- 1 x Fast charger.

K-18VBAT5



5.0Ah LITHIUM-ION Battery



5.0 Ah

- 5 Ah battery.
- Weight 0.65kg

K-Toolbag



Tool Bag



- Large heavy duty tool bag.
- Perfect for carting your Keyang kit around the building sites.



BL brushless motor



CS-7S



7-1/4" Circular Saw

- Lightweight high powered 1100 watt circular saw.
- Die-cast aluminium base.



- Powerful blower to clear the line of cut when in use.
- Electronic constant speed control provides maximum power under load.

Weight	3.0 kg
Input power	1100 W
No load speed (rpm)	5500
Max. dia.	Ø 185 mm
Max. cut depth. (90°)	65 mm
Max. cut depth. (45°)	45 mm

HC-14K



14" Metal Cut Off Saw

- Powerful 2300 watt motor.
- Ideal for cutting steel round bar, round pipe and square pipe.
- Safety wheel cover to protect the user.



Weight	16.3 kg
Voltage	230 V
No load speed (rpm)	3800
Rated power	2300 W
Capacity - steel round bar	Ø 58 mm
Capacity - steel round pipe	Ø 110 mm
Capacity - steel square pipe	110x130 mm





DMV-13K



13mm Impact Hammer Drill

- Compact 650w impact hammer drill.
- 13mm keyless heavy duty chuck.
- Easy selection of drilling mode with switch on top of machine.
- Great all rounder drill with the ability to drill into masonry, metal and timber.
- Robust carry case.



Weight	1.65 kg
No load speed (rpm)	0~2800
No load speed (bpm)	0~44,800
Power input	650 W
Class	Double Insulation
Chuck	13mm Keyless

PHD-283B



2kg SDS Plus Rotary Hammer Drill

- Powerful 800w motor delivers exceptional power.
- 3 mode that enables drill, hammer drill and chisel.
- Great compact 2kg rotary hammer with drilling capacity of 28mm into masonry.
- Brushed shift that gives full power in both forward and reverse.
- Chisel function great for removing tiles off walls.
- Delivers 3.2 joules of power.
- Robust carry case.



Weight	2.9 kg
Power input	800 W
Forward / Reverse	Brush Shift
No-load speed (rpm)	0 . 1,250
Load impact rate (bpm)	0 4,000
Single impact energy	3.2 Joules
Max. drilling range Concrete	Ø 28mm
Max. drilling range Wood	Ø 30mm
Max. drilling range Steel	Ø 13mm
Tool holder system	SDS-plus
3 mode	Drill / Chisel / Hammer



Call ICCONS Today for a demonstration

PHD-40MV



5kg SDS Max Rotary Hammer Drill

- Powerful 1100watt motor delivers exceptional power.
- 2 mode allowing user to hammer drill and chisel.
- Vibration control system that makes it more comfortable when drilling with less fatigue.
- Variable speed dial with 6 speeds to choose from.
- Soft start.
- 40mm drilling capacity into masonry.
- Robust carry case.

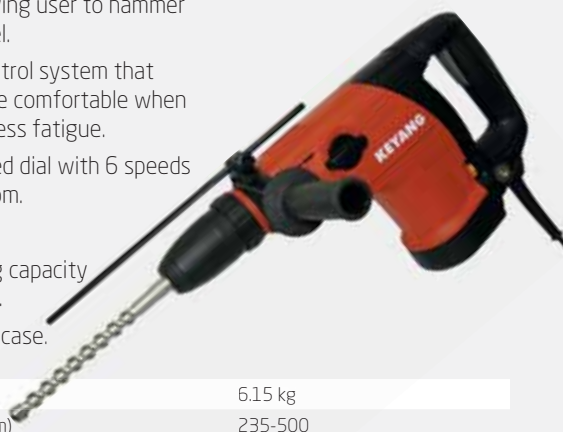

Weight	6.15 kg
No load speed (rpm)	235-500
No load speed (bpm)	1350-2870
Power input	1100 W
Impact force	7.5 Joules
Max. drilling capacity	Ø 40mm Concrete drill bit
Max. drilling capacity	Ø 105mm Core bit
Tool holder system	SDS Max.



DG-850



850W 4" Angle Grinder

- 100mm angle grinder .
- Great size grinder for the hard to get to jobs.
- Enhanced motor life with dust protection on motor.
- Comfortable housing grip.



Weight	1.6 kg
No load speed (rpm)	11000
Spindle size	M10 mm
Max. Diameter	Ø 100 mm
Power input	850 W

DG-852



850W 5" Angle Grinder

- 125mm angle grinder.
- Powerful 850 watt motor.
- Enhanced motor life with dust protection on motor.
- Comfortable housing grip.



Weight	1.6 kg
No load speed (rpm)	11000
Spindle size	M14 mm
Max. Diameter	Ø 125 mm
Power input	850 W



DG-1400A



1400W 5" Angle Grinder

- Electronic constant speed control provides maximum power under load.
- Anti vibration side handle.
- Great for any industrial workshop.
- Restart protection : grinder will not start if switch is on when plugging in to wall socket, for safety switch needs to be disengaged.



Weight	1.8 kg
No load speed (rpm)	11000
Spindle size	M14 mm
Max. Diameter	Ø 125 mm
Power input	1400 W
Nominal voltage	230 V
Frequency	50 Hz

DG-1400V



1400W 5" Angle Grinder variable speed

- Variable speed feature allowing the user to chose different speeds for different applications.
- Anti vibration side handle.
- Great for any industrial workshop.
- Restart protection : grinder will not start if switch is on when plugging in to wall socket, for safety switch needs to be disengaged.



Weight	1.8 kg
No load speed (rpm)	2800 -11000
Spindle size	M14 mm
Max. Diameter	Ø 125 mm
Power input	1400 W



DG-924AVT (S/S)



2400W 9" Angle Grinder

- Powerful 2400 watt motor.
- Soft start.
- Anti vibration side handle.
- 180° rotating rear handle ideal for varied working angles.
- Great for any industrial workshop.



Weight	4.9 kg
No load speed (rpm)	6500
Spindle size	M14 mm
Max. Diameter	Ø 230 mm
Power input	2400 W

ICCONS® PTY LTD

VICTORIA - HEAD OFFICE

12-18 Produce Drive, Dandenong South,
Victoria, 3175

P: **03 9706 4344**

F: **03 9768 3329**

E: **sales@iccons.com.au**

NSW Branch

Unit A, 17 Seddon Street, Bankstown,
New South Wales, 2200

P: **02 9791 6869**

F: **02 9790 8404**

E: **salesnsw@iccons.com.au**

QLD Branch

42-44 Nealdon Drive, Meadowbrook,
Queensland, 4131

P: **07 3200 6455**

F: **07 3299 7548**

E: **salesqld@iccons.com.au**

S.A Branch

15 Light Terrace, Thebarton,
South Australia, 5031

P: **08 8234 5535**

F: **08 8354 4689**

E: **salessa@iccons.com.au**

W.A. Branch

90 Christable Way, Landsdale,
Western Australia, 6065

P: **08 6305 0008**

F: **08 6305 0011**

E: **saleswa@iccons.com.au**

NORTHERN TERRITORY

Unit 1, 14 Menmuir Street, Winnellie,
Northern Territory 0820

P: **08 8947 2758**

F: **08 8947 2758**

E: **salesnt@iccons.com.au**

NEW ZEALAND

Sesto Fasteners

5E Piermark Drive, Rosedale, Auckland,
New Zealand 0630

P: **+64 027 526 6403**

E: **sestofasteners@gmail.com**

ICCONS (Thailand) Co. Ltd.

55 Phetkasem 62/3, Bangkhuae,
Bangkok 0160

P: **+ 66 2 801 0764**

F: **+ 66 2 801 0764**

M: **+ 66 8 1 710 8745**

E: **icconsthailand@hotmail.com**



ON-SITE EVERYDAY

